

Bulletin of Tibetology

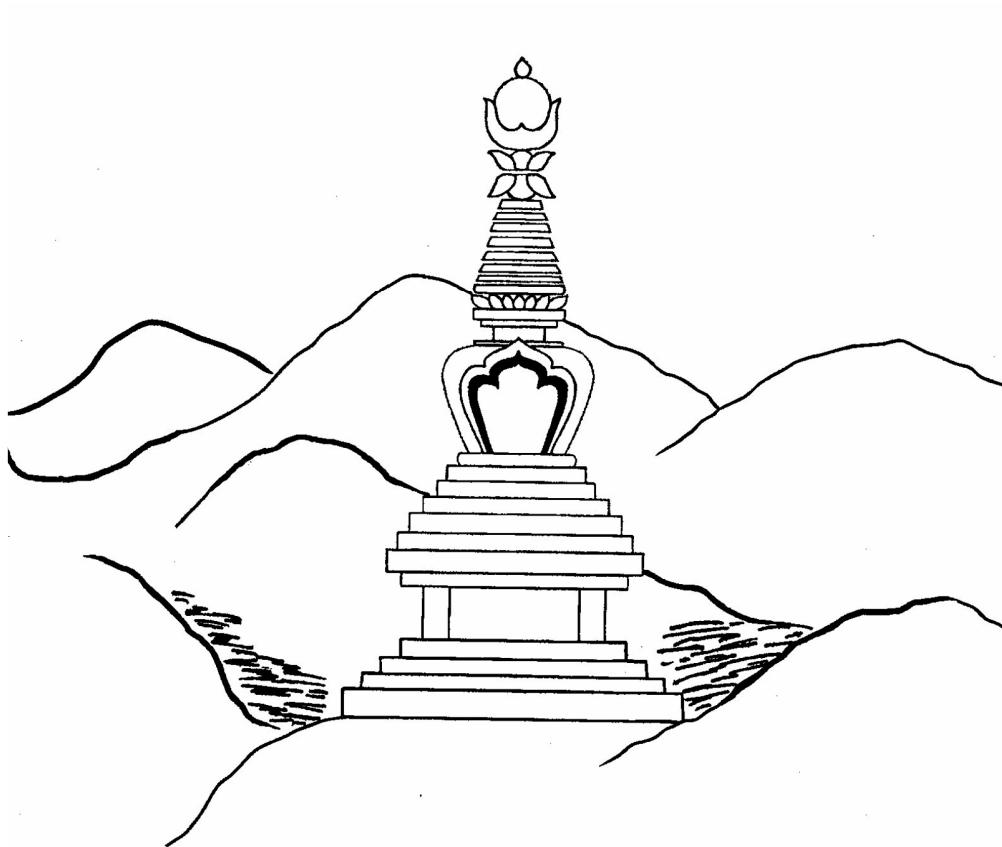

VOLUME 44

NO. 1 AND 2

2008

NAMGYAL INSTITUTE OF TIBETOLOGY
GANGTOK, SIKKIM

The Bulletin of Tibetology seeks to serve the specialist as well as the general reader with an interest in the field of study. The motif portraying the Stupa on the mountains suggests the dimensions of the field.

Bulletin of Tibetology

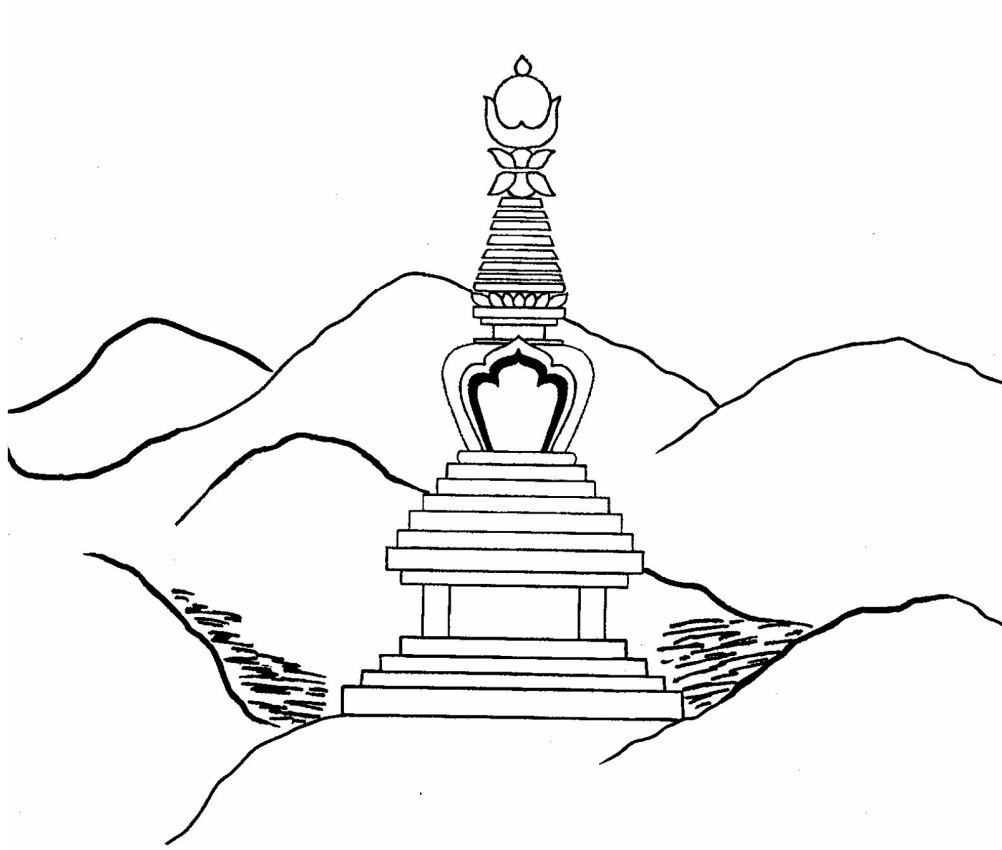

VOLUME 44

NO. 1 AND 2

2008

NAMGYAL INSTITUTE OF TIBETOLOGY
GANGTOK, SIKKIM

Patron

HIS EXCELLENCY SHRI BALMIKI PRASAD SINGH, THE GOVERNOR OF SIKKIM

Advisor

TASHI DENSAPA, DIRECTOR NIT

Editorial Board

FRANZ-KARL EHRHARD
ACHARYA SAMTEN GYATSO
SAUL MULLARD
BRIGITTE STEINMANN
TASHI TSERING
MARK TURIN
ROBERTO VITALI

Editor

ANNA BALIKCI-DENJONGPA

Assistant Editors

TSULTSEM GYATSO ACHARYA
THUPTEN TENZING

The Bulletin of Tibetology is published bi-annually by the Director, Namgyal Institute of Tibetology, Gangtok, Sikkim. Annual subscription rates: South Asia, Rs150. Overseas, \$20.

Correspondence concerning bulletin subscriptions, changes of address, missing issues etc., to: Administrative Assistant, Namgyal Institute of Tibetology, Gangtok 737102, Sikkim, India (nitsikkim@yahoo.co.in). Editorial correspondence should be sent to the Editor at the same address.

Submission guidelines. We welcome submission of articles on any subject of the history, language, art, culture and religion of the people of the Tibetan cultural area although we would particularly welcome articles focusing on Sikkim, Bhutan and the Eastern Himalayas. Articles should be in English or Tibetan, submitted by email or on CD along with a hard copy and should not exceed 5000 words in length.

The views expressed in the Bulletin of Tibetology are those of the contributors alone and not the Namgyal Institute of Tibetology. An article represents the view of the author and does not reflect those of any office or institution with which the author may be associated.

PRINTED AT BABA OFFSET PRESS WORKS PVT. LTD., GANGTOK, SIKKIM

BULLETIN OF TIBETOLOGY

Volume 44 Number 1 and 2 2008

CONTENTS

FRANZ-KARL EHRHARD “Turning the Wheel of the Dharma in Zhing sa Va lung”: The dPal ri sPrul skus (17 th to 20 th centuries)	5
MÉLANIE VANDENHELSEN Narrations about a yogī in sikkim	31
P.K. GAUTAM Buddhism in the Himalayan belt	61
SONAM WANGDI Tibet today: a region of China	85
JENNY BENTLEY Láso múng <i>sung</i> : Lepcha oral tradition as a reflexion of culture	99
<i>Sikkimese biographies</i>	
PEMA WANGCHUK S. Mahinda Thero: the Sikkimese who gave Lankans their freedom song	139
DASHO P.W. SAMDUP A Brief Biography of Kazi Dawa Samdup (1868-1922)	155
<i>Reports</i>	
JOHN BRAY Conference Report: Golden Jubilee Conference of the Namgyal Institute of Tibetology, Gangtok, Sikkim, 1-5 October 2008	159
SAUL MULLARD Recent acquisitions to the Namgyal Institute of Tibetology holdings and future publications	163
ANNA BALIKCI-DENJONGPA The British Residency in the Himalayan State of Sikkim: a heritage building restored to its former glory	171

Book reviews

ALEX MCKAY *Bahudhā and the Post 9/11 World.* 181
Balmiki Prasad Singh

SAUL MULLARD *A Rosary of Rubies: The chronicle of the
Gur-rigs mDo-chen Tradition from South-Western Tibet.* 185
Franz-Karl Ehrhard.

MARK TURIN *Tibetan Modernities: Notes from the Field
on Cultural and Social Change.* Edited by Robert Barnett
and Ronald Schwartz. 187

Obituaries

Princess Pema Tsedeun of Sikkim (1924-2008) 195
Founder Member, Namgyal Institute of Tibetology

Tashi T. Topden (1948-2009) 199
Director, Namgyal Institute of Tibetology 1995-2002

Notes on contributors 201

“TURNING THE WHEEL OF THE DHARMA
IN ZHING SA VA LUNG”
THE DPAL RI SPRUL SKUS (17TH TO 20TH CENTURIES)

FRANZ-KARL EHRHARD
University of Munich

1. *Introduction*

Among the incarnation lineages or “lines of rebirth” (*skyes rabs*) which concentrated their activities within Sikkim, the “hidden land” (*sbas yul*) called ’Bras mo ljongs, the most outstanding—both on account of its religious legacy in Tibet and its role in later Sikkimese history—is that of lHa btsun Nam mkha’ ’jigs med (1597-1653). This master, also known as Kun bzang rnam rgyal and dubbed the “Madman from Kong[po]” (*kong smyon*), was among the three Tibetan teachers considered as spiritual masters of the first Buddhist king of the country, and he is still celebrated today for having introduced the doctrine of the “Great Perfection” (*rdzogs chen*) to this part of the Himalayas. The course his life took is a matter of general knowledge, and his collected writings are still extant. Among these one finds various texts concerning Sikkim. Of special interest is one text devoted to his journey to the hidden land which started in the year 1646; it was at that time that Nam mkha’ ’jigs med opened the “Rice Valley” and established sundry hermitages along the way.¹

In comparison to these sources, the known details of the short life of Ngag dbang Kun bzang ’jigs med (b. 1656), the immediate re-embodiment of lHa btsun Nam mkha’ ’jigs med, are quite sparse. But we do know that his incarnation status was acknowledged by the Fifth Dalai Bla ma Ngag dbang Blo bzang rgya mtsho (1617-1682) and that

¹ For a biographical account of lHa btsun Nam mkha’ ’jigs med as a master of the rNying ma pa school, see Dudjom Rinpoche (1991: 818-620). A full treatment of the stages of his life and the next three members of the “chain of incarnations of lHa btsun [Nam mkha’ ’jigs med]” (*lha btsun sku phreng*) is contained in lHa Tshe ring: *Blo gsar gzhon nu dga’ ston*, pp. 65-195. The writings describing his travels in Sikkim fall under the genre of “route descriptions” (*lam yig*); see especially Nam mkha’ ’jigs med: *Rab gsal nyin byed ’bar ba’i ’od stong*, pp. 462.3 ff. This seems to be the work referred to in local historiography as the “book describing the various caves and peaks in Sikkim after having visited the places on foot”; see Steinmann (1998:135). It is used as a literary source for describing the arrival of lHa btsun Nam mkha’ ’jigs med in Sikkim in Mullard (2005: 35-36) and Mullard (2009: 168-178).

he was clearly granted a monastic estate in Central Tibet by the newly established dGa' ldan pho brang government.²

The situation is different with respect to the third member of the incarnation lineage, inasmuch as a compendious autobiography of lHa btsun sPrul sku 'Jigs med dpa' bo (b. 1682) has survived. This work sheds light on the political and religious conditions in Sikkim under Phyag rdor rnam rgyal (1686-1717) and 'Gyur med rnam rgyal (1707-1734), respectively the third and fourth Buddhist rulers—particularly the spread of the teaching traditions of sMin grol gling and the “new treasures” (*gter gsar*) of Rig 'dzin gTer bdag gling pa (1646-1714). These ties between the rNying ma pa monastery in Central Tibet and the royal court became even closer when in 1719 the wife and daughters of Rig 'dzin gTer bdag gling pa escaped the Dzungar armies in Tibet and took refuge in the hidden land of 'Bras mo ljongs. The party was welcomed by lHa btsun sPrul sku 'Jigs med dpa' bo and the ruler 'Gyur med rnam rgyal, and later one of the daughters was given in marriage to the king. Another daughter, the famous Mi 'gyur dpal gyi sgron ma (1699-1769), conferred various teachings on the religious authorities of the country, including lHa btsun sPrul sku 'Jigs med dpa' bo. The latter accompanied Mi 'gyur dpal gyi sgron ma when she went back to Tibet, visiting together with her sacred sites associated with his predecessor (among others, Grub gnas Padma thang). During these travels he made use of the text describing these sites penned by lHa btsun Nam mkha' 'jigs med.³

² Details on the life of Ngag dbang Kun bzang 'jigs med can be found in lHa Tshe ring: *Blo gsar gzhon nu'i dga' ston*, pp. 143.3-147.9. The monastic estate which the incarnation received from the dGa' ldan pho brang government was known as dPal ri dgon pa or Chu mo dPal gyi ri, a former establishment of the 'Brug pa bKa' brgyud pa school; see *ibid.*, pp. 145.5-17. This information can be gleaned from the autobiography of the third lHa btsun sPrul sku, who seems to have based his account on oral sources; see 'Jigs med dpa' bo: *mThong grol chen mo*, pp. 42.4-44.1. For the location of the monastery between Shigatse and Gyantse, see Waddell (1991: 277).

³ The autobiography of 'Jigs med dpa' bo served as the main source for the presentation of his life in lHa Tshe ring: *Blo gsar gzhon nu'i dga' ston*, pp. 147.10-187.8; compare Mullard (2005: 43-46) and Vandenhelsken (2006: 79-82) regarding 'Jigs med dpa' bo's place in Sikkimese political and religious history. The text contains a complete “record of teachings received” (*gsan yig*) by the Third lHa btsun sPrul sku, including the teaching traditions obtained from Rig 'dzin gTer bdag gling pa; see 'Jigs med dpa' bo: *mThong grol chen mo*, pp. 118.2-196.1. The details of the arrival of rJe btsun Mi 'gyur dpal gyi sgron ma in Sikkim together with her mother and two sisters in the year 1719 can be found *ibid.*, pp. 525.3-533.4; further details of the marriage between the daughter of gTer bdag gling and 'Gyur med rnam rgyal, the fourth Buddhist ruler of Sikkim, are given in Mullard (2009: 258-259). For the events of the flight from Tibet and the sojourn in 'Bras mo ljongs as described in the

The next two members of the incarnation lineage of lHa btsun Nam mkha' 'jigs med visited Sikkim during the reign of rNam rgyal phun tshogs (1733-1779), the fifth Buddhist ruler of Sikkim. Their activities are particularly associated with the sacred site of Do bo lung. Like his predecessors Kun bzang 'jigs med rgya mtsho, the Fourth lHa btsun sPrul sku, had received his training in sMin grol gling, and on his first journey to 'Bras mo ljongs he opened a hidden land known as Do lung sKyid mo tshal. The monastic community established there was later cared for by his successor, Padma bDe chen rgya mtsho, the Fifth lHa btsun sPrul sku. It was to that remote spot in the Sikkimese Himalayas where personal belongings of lHa btsun Nam mkha' 'jigs med, including old books and the collected writings of the master, were brought to safety during an invasion of Gorkha troops into Sikkim in the year 1816.⁴

In the following I will look more closely at the lives of the first three members of this incarnation lineage and try to identify the main persons involved in establishing it. Among them, it turns out, are persons who had close family ties to Nam mkha' 'jigs med and who produced incarnation lineages of their own.

2. *The Fifth Dalai Bla ma and the lHa btsun sPrul skus*

Having opened the hidden land 'Bras mo ljongs and revealed treasures in a "pure vision" (*dag snang*), lHa btsun Nam mkha' 'jigs med returned to Tibet in 1651 and offered his visionary teachings to the Fifth Dalai Bla ma Ngag dbang Blo bzang rgya mtsho. This meeting is recorded in the autobiography of this former religious and secular head of Tibet. It took place at the monastery of 'Bras spungs in the vicinity of lHa sa. Before the meeting lHa btsun Nam mkha' 'jigs med had

biography of rJe btsun Mi 'gyur dpal gyi sgron ma, see Khyung po ras pa: *Dad pa'i gdung sel*, pp. 76.2-100.2; the suppression of the rNying ma pa school during the period of the Dzungar invasion is put in context in Ehrhard (2003: 662-663). The third lHa btsun sPrul sku used the work of his predecessor on earlier occasions, too, for the purpose of identifying sacred sites in 'Bras mo ljongs; see 'Jigs med dpa' bo: *mThong grol chen mo*, pp. 396.3 & 481.4.

⁴ For the life of Kun bzang 'Jigs med rgya mtsho and the foundation of the monastery of Do lung Rig 'dzin mchog grub gling, see lHa Tshe ring: *Blo gsar gzhon nu'i dga' ston*, pp. 187.9-195.2. Compare the description of the activities of the Fourth and Fifth lHa btsun sPrul skus during the rule of rNam rgyal phun tshogs in Chos dbang: *bDen pa kun gsal*, pp. 154.4-17 & 158.10-159.14. The information that the personal belongings of lHa btsun Nam mkha' 'jigs med and individual ritual items were safeguarded in Do bo lung during the Gorkha invasion is based on White (1999: 66-67).

encountered Zur Chos dbyings rang grol (1604-1669), one of the teachers of the Fifth Dalai Bla ma, at Tshal Gung thang, to the north-east of the Tibetan capital:

Kun bzang rnam rgyal, the adept of [the doctrine of] the Great Perfection from Kong po, arrived after he had opened the gate of the sacred site 'Bras [mo] ljons and [witnessed] the appearance of many profound teachings [in] a vision at lHa ri Rin c[h]en spungs [= lHa ri snying phug]. [He came] in order to perform religious ceremonies as a means of [ensuring] the happiness of the Tibetan subjects. At [Tshal] Gung thang he offered full pronouncements of his doctrine to the noble teacher [= Zur Chos dbyings rang grol]. He also performed, together with the master and his disciples, one ritual practice of the *Rig 'dzin srog sgrub* [cycle].

He came in person to [the monastery of] 'Bras spungs, whence an auspicious connection was established [that favoured] his staying a long time [there]. He gave different kinds of soil, stones [and] wood from 'Bras [mo] gshongs [to me]—a rainbow crystal and so forth. To him I offered [in return] the reading authorization for a secret scripture of the *Tshe sgrub bdud rtsi 'khyil ba*, [one] of the New Treasures of the Great Vidyādhara [= Rig 'dzin gTer bdag gling pa].⁵

During his stay in Tshal Gung thang lHa btsun Nam mkha' 'jigs med composed several literary works, including a “secret biography” (*gsang ba'i rnam thar*) of one Khrag thung Hūṃkar. (This is obviously an alternative spelling of Hūṃkara, the name of an important early

⁵ See Ngag dbang Blo bzang rgya mtsho: *Du kū la'i gos bzang*, vol 1, p. 317.13-21 (*kong po rdzogs chen pa kun zang rnam rgyal gyis 'bras gshongs gnas sgo phye nas lha ri rin cen spungs par dag snang gi zab chos mang du byung ba bod 'bangs bde thabs kyi rim gro mdzad par byon te gung thang du rje bla mar chos bka' rnam rdzogs par phul / dpon slob lhan du rigs [= rig] 'dzin srog sgrub kyi sgrub pa zhig kyang mdzad / 'bras spungs su ngos byon gyis yun du gnas pa'i rten 'brel bsgrigs shing 'ja' shal mtshan sogs 'bras gshongs kyi sa sna rdo shing du ma byin / phar rigs [= rig] 'dzin chen po'i gter gsar gyi tshe sgrub bdud rtsi 'khyil ba'i gsang yig lung phul*). These events are also recorded in the biography of Zur Chos dbyings rang grol written by the Fifth Bla ma; see Ngag dbang Blo bzang rgya mtsho: *Theg mchog bstan pa'i shing rta*, p. 197.1-3, and lHa Tshe ring: *Blo gsar gzhon nu'i dga' ston*, p. 137.5-16. For the activities of Zur Chos dbyings rang grol at Tshal Gung thang according to the register of the monastery, see Sørensen & Hazod (2007: 246-250). It is reported that as a result of the meeting between the Fifth Dalai Bla ma and lHa btsun Nam mkha' 'jigs med a relationship was established between Ngag dbang Blo bzang rgya mtsho and Phun tshogs rnam rgyal, the first Buddhist ruler of Tibet; see Chos dbang: *bDen don kun gsal*, pp. 117.21-118.13. Phun tshogs rnam rgyal was accorded the status of Dharmarāja on that same occasion and received formal notice of this along with various ritual implements; these items, too, were later safeguarded at Do bo lung.

lineage-holder of the “spoken teachings” (*bka' ma*) of the rNying ma pa school). The person in question is described by the author as his main spiritual son and a direct “nephew” (*rigs dbon*), and reference is made to his collected writings and to the fact that they were transmitted as a *gsung 'bum* collection. The work itself was composed to commemorate his death and is testimony to the fact that he had quite close spiritual and family ties to lHa btsun Nam mkha' 'jigs med. The date of his passing is given as the twenty-first day of the twelfth Tibetan month of the iron [male] tiger year [= 1650]. According to the illumination on the introductory folio of the text, this nephew of lHa btsun Nam mkha' 'jigs med was known as “Noble Rig 'dzin lhun grub, the Great Vajradhara” (*rje rig 'dzin lhun grub rdo rje 'dzin pa chen po*).⁶

A few years later, in 1660, the reincarnation of lHa btsun Nam mkha' 'jigs med was introduced to the Fifth Dalai Bla ma, and a religious name was given to the young boy of Bhutanese origin. During this ceremony, as on other occasions, one Chos dbyings lhun grub was among those admitted into the presence of the Fifth Dalai Bla ma. He, too, is called a “nephew” (*dbon po*) of lHa btsun Nam mkha' 'jigs med:

I seized the first lock of hair of the rebirth of lHa btsun Nam mkha' 'jigs med, the adept of [the doctrine of] the Great Perfection from Kong po, and gave him the name Ngag dbang Kun bzang 'jigs med. At the urging of Chos [dbyings] lhun[grub] (d. 1684), the nephew [of lHa btsun Nam mkha' 'jigs med], I wrote something [to the effect] that my long life and that of the reincarnation should be joined together on equal terms.⁷

⁶ See Nam mkha' 'jigs med: *Khrag 'thung hūṃ dkar gyi gsang ba'i rnam thar*, fol. 1b. Concerning Hūṃkara, who was born in Nepal and played an important role in transmitting the spoken teaching tradition of the Yang dag precepts of Mahāyoga, see Dudjom Rinpoche (1991: 475-477). For the date of the composition of the text, see Nam mkha' 'jigs med, op. cit., fol. 7b/4: “Written at the miraculously manifested palace of [Tshal] Gung thang on the twenty-first [day] of the second month, [the day] of the memorial offerings for this noble one” (*zhes rje 'de nyid kyi dus mchod zla ba gnyis pa'i nyer gcig la gung thang sprul pa'i pho brang du bris pa'o*); compare the final line of the colophon, fol. 8a/1-2: “They are immaculate words composed at the palace of bDe ba rdo rje in [Tshal] Gung thang in the second month of the iron [female] hare [year] [= 1651] (*ljags yos dbo yi zla bar gung thang bde ba rdo rje pho brang du mdzad pa'i zhal gsung dri ma med pa yin 'dug go*). For the extant writings of Rig 'dzin lhun grub, see Appendix I; they include, along with spiritual songs, a substantial collection of “instructions” (*zhal gdams*).

⁷ See Ngag dbang Blo bzang rgya mtsho: *Du kū la'i gos bzang*, vol. 1, p. 593.2-6 (*kong po rdzogs chen pa lha btsun nam mkha' 'jigs med kyi sku skye'i skra phud blangs mtshan ngag dbang kun bzang 'jigs med du btags / dbon po chos lhun pas*

Accordingly, there existed at least two nephews of lHa btsun Nam mkha' 'jigs med, each of whom was a religious master in his own right, and one of whom was directly involved in the process of acknowledging the status of his uncle's reincarnation, and thus in initiating the lineage of the lHa btsun sPrul skus.

3. *The Two lHa dbon and their Reincarnations*

The autobiography of lHa btsun sPrul sku 'Jigs med dpa' bo contains a great deal of information on the events surrounding the recognition of the next reincarnation. The whole process began with a prophecy concerning the right candidate, as requested by the Fifth Dalai Bla ma, obviously in the year of his own death, from the gNas chung oracle. Once again mention is made of Chos dbyings lhun grub, who had already had a hand in installing the previous lHa btsun sPrul sku. As Chos dyings lhun grub was now residing in Sikkim and signs had already manifested that the end of his life was approaching, the question arose among the concerned authorities—including bsTan srung nam rgyal (1644-1699), the second Buddhist ruler of the country—as to who would be a possible candidate for the task of looking after the new reincarnation:

On that occasion, when the time was near that the expanse that had manifested as a mirage taken to be real—[that is, the body] of Chos dbyings lhun grub, the youngest of the three nephews [who were] Dharma sons of the glorious Khrag 'thung chen po [= lHa btsun Nam mkha' 'jigs med]—would perish in Sikkim, those [persons] dwelling in his presence, including gNam lcags (the master [and his] disciples), Srid zhi khyab brdal, gSang chen dbang po and the king of Sikkim, bsTan srung nam rgyal, asked [Chos dbyings lhun grub] if the

bskul pa'i nged rang dang sku skye'i brtan bzhugs bsdebs mtshungs su yod pa zhig bris); the same account can be found in lHa Tshe ring: *Blo gsar gzhon nu'i dga' ston*, pp. 143.14-144.2. The Fifth Dalai Bla ma and Chos dbyings lhun grub had met on an earlier occasion, during which the former was requested to compose a similar long-life prayer for the reincarnation; see Ngag dbang Blo bzang rgya mtsho: *Du kū la'i gos bzang*, vol. 1, p. 586.1-2 (*dbon po chos lhun pas bskul ba'i lha btsun kun bzang rnam rgyal gyi sku skye'i brtan bzhugs byas*), and lHa Tshe ring: *Blo gsar gzhon nu'i dga' ston*, p. 143.13-14. After the early death of Ngag dbang Kun bzang 'jigs med, another prayer was composed by the Fifth Dalai Bla ma upon the request of Chos dbying lhun grub for his swift rebirth; see Ngag dbang Blo bzang rgya mtsho: *Rab dkar dge ba'i chu klung*, vol. 1, pp. 349.3-350.3.

Reincarnation from [g]Zar would be worthy to take responsibility for [the reincarnation of] the adept of the Great Perfection.⁸

According to this information, there were a total of three nephews of IHa btsun Nam mkha' 'jigs med, of whom Chos dbyings lhun grub was the youngest. As already noted, the one whose name was Rig 'dzin lhun grub—his uncle was personally involved, after the journey to 'Bras mo ljongs, in establishing his religious legacy—died at a quite early age. Up to now no information has surfaced on the name and dates of the third nephew.

The autobiography of 'Jigs med dpa' bo provides further details on the early education of the Second IHa btsun sPrul sku. It turns out that there was a reincarnation of Rig 'dzin lhun grub, but unfortunately his name is not given in the text. He is called “the reincarnation of Rig 'dzin lhun grub, the nephew of IHa[btsun Nam mkha' 'jigs med]” (*lha dbon rig 'dzin lhun grub kyi yang srid*). An equivalent expression is found in connection with the second nephew whom we know by name, he having been followed by an incarnation perhaps of Sikkimese origin. This latter is known as “the reincarnation of Chos dbyings lhun grub, the nephew of IHa[btsun Nam mkha' 'jigs med]” (*lha dbon chos dbyings lhun grub kyi yang srid*). This reincarnation bears the name [mKhan chen] Rol pa'i rdo rje. He was a close associate of 'Jigs med dpa' bo starting from the days of his early training in the monastery of [g]Zar. A more detailed study of the period when 'Jigs med dpa' bo was active in Sikkim and at the court of Phyag rdor nam rgyal and

⁸ See 'Jigs med dpa' bo: *mThong grol chen mo*, p. 41.1-4 (*de'i tshe na dpal khrag thung chen po'i chos sras rigs dbon gsum yod pa'i chung mtha' chos dbyings lhun grub dpal gyi 'bras mo ljongs su rtag 'dzin sgyu ma'i snang tshul rgya zhig par nye skabs / drung du gnas pa dpon slob gnam lcags dang / srid zhi khyab gdal dang / gsang chen dbang po / 'bras ljongs rgyal po bstan bsrung nam rgyal la sogs pa rnams kyi rdzogs chen pa'i 'gan khu da cha / zar sprul sku 'os sam zhus par*). Compare IHa Tshe ring: *Blo gzar gzhon nu'i dga' ston*, pp. 151.9-153.1, where Chos dbyings lhun grub's answer is given and the early education of 'Jigs med dpa' bo is recapitulated up to his twelfth year. The candidate for inviting the Third IHa btsun sPrul sku to his former residence turned out not to be the proposed “Reincarnation from [g]Zar” (*zar sprul sku*) but the mentioned gNam lcags, who installed the young boy at dPal gyi dgon pa also known as Chu mo dPal gyi ri. Afterwards the youth studied under Kun bzang Tshe dbang, also known as the “Reincarnation from dPal ri” (*dpal ri sprul sku*), who seems to have been none other than the “Reincarnation from [g]Zar.” The monastery of [g]Zar lies to the south-east of the lake mTsho mo Drel thang and is not far from the Tibet-Sikkim border. Its foundation is associated with the journey undertaken by IHa btsun Rin chen nam rgyal; see Waddell (1991: 49). This monastery and its incarnation lineage is different from the one of the same name presented in this article.

'Gyur med rnam rgyal will surely set in greater relief the religious influence of these two masters, who were regarded respectively as reincarnations of lHa btsun Nam mkha' 'jigs med and of the latter's nephew Chos dbyings lhun grub.⁹

As the early phase of the incarnation lineage which goes back to Rig 'dzin lhun grub, the other nephew, is not documented in a comparably informative way, I now turn to literary sources which shed light on the later members of the lineage and on their activities in Tibet and the Sikkimese Himalayas.

4. *The Lineage of the dPal ri sPrul sku*

In a historiographical work of the rNying ma pa school completed in 1882 we find the following information about a religious master who was part of the incarnation lineage which traces its origin back to Rig 'dzin lhun grub, regarded in this source as the brother of lHa btsun Nam mkha' 'jigs med:

Among those who in later times have held the teaching tradition of sMin [grol] gling is my own guide, he of accomplished speech, to whom I am most grateful, [namely] Rig 'dzin Padma dBang rgyal rdo rje (1779-1841), the noble incarnation of Pad ri [= dPal ri] [in] gTsang.

It was prophesied that this noble one would be the reincarnation of the true Indian Vidyādhara Hūṃ chen Kara. He was born in Yid 'ong sa mang [in] sPo bo as the re-embodiment of him [who is known as] rDo rje Chos dbyings yongs grol, who had come in succession after Khrag 'thung Hūṃkara, the brother of lHa btsun Nam mkha' 'jigs med. He was installed on the throne of Pad ri [= dPal ri] and the lHa lung residence by Klong gsal, the treasurer of the noble previous incarnation [i.e. rDo rje Chos dbyings yongs grol]. At sMin [grol]

⁹ For references to the reincarnation of Rig 'dzin lhun grub in the year 1687, see 'Jigs med dpa' bo: *mThong grol chen mo*, pp. 45.4 ff. The first meeting between 'Jigs med dpa' bo and [mKhan chen] Rol pa'i rdo rje is recounted *ibid.*, pp. 74.5 ff. In this passage, the father of the reincarnation of Chos dbyings lhun grub is called a "king" (*radza= rāja*); this implies that [mKhan chen] Rol pa'i rdo rje was the physical son of bsTan srung rnam rgyal. Phyag rdor rnam rgyal, the third Buddhist ruler of Sikkim, is characterized in local historiography as being connected with three "great beings" (*skyes chen gsum*). These persons are the third lHa btsun sPrul sku 'Jigs med dpa' bo, mKhan chen Rol pa'i rdo rje (the reincarnation of lHa dbang Chos nyid lhun grub [= lHa dbon Chos dbyings lhun grub]) and gZar dPal ri sprul sku; see Chos dbang: *bDen don kun gsal me long*, p. 126.8-16. If the above observation is true, Phyag rdor rnam rgyal and mKhan chen Rol pa'i rdo rje would have been brothers. For further information on the religious revival and reform due to the influential role of 'Jigs med dpa' bo at the Sikkimese court, compare Mullard (2009: 252-264).

gling he offered a lock of his hair to the previous throne-holder, 'Gyur med Phrin las rnam rgyal; he studied with aspiration in sMin [grol] gling itself and—relying on the lotus feet of many great beings, headed by the great throne-[holder] (i.e. 'Gyur med Phrin las rnam rgyal)—listened extensively [to the Buddhist teachings].

As he had seen through to completion the approaching to [and] attaining of [the presence of his personal deity] at many solitary places [that housed such treasure cycles] as *Bla ma zhi drag*, *Thugs rje chen po bde gshegs kun 'dus* [and] *sGrub sde brgyad pa* [of Rig 'dzin gTer bdag gling pa], the qualities associated with spiritual experience [and] realisations were born [in him]. When the time arrived to act for the benefit of beings by caring for others with compassion, he was honoured as the religious teacher of the king, the monarch of 'Bras [mo] ljongs [= gTsug phud rnam rgyal (1785-1864)], [and] his activities in the regions of the hidden place [were] extensive. In dBus gtsang, too, [and] in the southern regions [and] in Nyang [po] [and] Kong [po] he acted solely for the benefit of the Buddhist doctrine [and] beings.

[He was of] particularly great vision in regard to the impartiality of [both] the new [and] old [mantras], above all [the teachings of] the Early Translations. Whatever he was able to hear and examine studiously the rare teaching traditions—and given the great wave of his desire to spread it joyfully to others—he offered [to disciples,] first and foremost the previous throne-holder, Sangs rgyas Kun dga' chos mchog from sMin [grol] gling. [He showed his] unsurpassable kindness in extending the life of the Buddhist doctrine at the end of time.

I myself, too, when I heard the name of this noble one, immediately sought his presence, and at Pad ri bKra shis 'od 'bar and the lHa lung residence—[these] two—obtained most of the treasure teachings of 'Ja' tshon [snying po] and gTer bdag gling pa; the upper and lower treasure mines (i.e. the treasure cycles of [respectively] Nyang ral Nyi ma'i 'od zer and Gu ru Chos kyi dbang phyug); the 'Dod 'jo bum bzang [of gTer bdag gling pa]; the *g.Yu thog snying thig*, the Seven Treasures [and the cycle] *Ngal gso skor [gsum]* of Klong chen [Rab 'byams pa]; the *Rig 'dzin srog sgrub* [and] *rDo rje snying po* [of lHa btsun Nam mkha' 'jigs med] and many other sMin grol gling teachings.

Afterwards [Rig 'dzin Padma dBang rgyal rdo rje] moved for a brief period to the region of Western Tibet for the great benefit of the Buddhist doctrine [and sentient] beings—in order, among other things, to turn back the foreign armies at the border. Upon orders of the central government [in Tibet] he established facilities (lit. 'means of happiness') in a fitting manner in important places [and] localities up to Gangs Ti se (i.e. Mount Kailāśa). In the iron [female] ox year [=

1841], at the age of sixty-three, while he was uninterruptedly turning the wheel of the Dharma in the region of Zhing sa Va lung, he demonstrated how to contract his physical form into the Dharmadhatu (i.e. passed away).

The precious high incarnation [of Rig 'dzin Padma dBang rgyal rdo rje] was born as the son of a government clerk in gZhis [kha] rtse [in] gTsang. He studied at sMin [grol] gling, and thanks to his having heard the pronouncements of the precious throne-holder (i.e. Sangs rgyas Kun dga' mchog) and lCags sbug rin po che O rgyan rNam grol dbang po, a direct disciple of the previous [incarnation], and others, he is [still] living and engaging in (lit. 'seizing') [actions] for the glory of the Buddhist doctrine and sentient beings.¹⁰

¹⁰ See Kun bzang Nges don klong yangs: *Nor bu do shal*, pp. 319.1-321.3 (*dus phyi su smin gling chos rgyun 'dzin pa'i nang nas mdzad pa phyag rjes bka' drin che ba bdag cag gi rnam 'dren dam pa gtsang pad ri sku gong ma rig 'dzin padma dbang rgyal rdo rje ste / dam pa 'di ni rgya gar gyi yang dag rig 'dzin slob dpon hūm chen ka ra'i rnam sprul du lung gis zin cing / lha btsun nam mkha' 'jigs med kyi sku mched khrag 'thung hūm ka ra nas rim par rdo rje chos dbyings yongs grol / de'i yang srid spo bo yid 'ong sa mang zhes par sku bltams / rje gong ma'i phyag mdzod klong gsal gyis pad ri dang / lha lung gdan sa'i khri la bkod / smin gling du khri rin po che 'gyur med phrin las rnam rgyal la gtsug phud phul / smin gling rang du thugs gnyer gsan sbyongs dang / khri chen gtso gyur gyi skyes chen mang po'i zhabs pad bsten nas gsan rgya cher mdzad / bla ma zhi drag thugs rje chen po bde gshegs kun 'dus / sgrub sde brgyad pa sogs dben gnas du mar bsnyen sgrub mthar phyin mdzad pas nyams rtogs yon tan 'khrungs / thugs rjes gzhan rjes su 'dzin pa'i 'gro don dus babs kyis 'bras ljongs sa spyod rgyal po'i dbu blar bkur te sbas gnas phyogs su phrin las che / gzhan yang dbus gtsang / lho rgyud / nyang kong phyogs su bstan 'gro'i don kho na mdzad cing / khyad par snga 'gyur gtso bor gyur pa'i gsar rnying ris med la dag snang che / chos rgyun dkon pa rnam rtsol ba chen po'i rtsad gcos kyis gsan gang thub dang / gzhan la spel bar skyo bsun med pa'i thugs dgongs brlabs po ches gtso cher smin gling du khri rin po che sangs rgyas kun dga' chos mchog la 'bul bar mdzad pa sogs dus mthar bstan pa'i srog 'thud pa'i bka' drin bla na med / bdag gis kyang dam pa 'di'i mtshan snyan thos 'dzin lam du son pas zhabs drung du bsnyegs nas / pad ri bkra shis 'od dang / lha lung gdan sa gnyis su 'ja' tshon dang / gter bdag gling pa'i gter chos phal cher dang / gter kha gong 'og / 'dod jo'i bum bzang / g.yu thog snying thig / klong chen mdzod bdun ngal gso skor / rig 'dzin srog sgrub / rdo rje snying po sogs smin grol chos bka' mang po'i bka drin thob / de nas mi ring bar stod phyogs su mtha dmag bzlog pa sogs bstan 'gro'i don chen slad du 'chi kha bsgyur gnang ste gangs ti si'i (= se'i) bar du sa gnad (= gnas) che sar gzhung sa'i bka' brel bde thabs legs par grub ste / zhing sa va lung phyogs su chos 'khor rgyun mi chad du bskor bzhin dgung lo re gsum sa lcags glang lor gzugs sku chos dbyings su bsdus tshul bstan pa slar yang / mchog sprul rin po che gtsar (= gtsang) gzhis rtse las drung gi sras su sku bltams pa smin gling du gsan sbyongs dang / khri rin po che dang / gong ma'i dngos slob lcags sbug rin po che o rgyan rnam grol dbang po sogs la chos bka' gsan bzhes kyis bstan 'gro'i dpal su 'tsho zhing gzhes pa'o).*

This account was written by a disciple of Rig 'dzin Padma dbang rgyal rdo rje who was a native of Kong po and who has left two autobiographical works to us along with his work on the history of the rNying ma pa tradition. With the help of both of them it is possible to date the encounter with the master to the year 1838; it took place at the stated lHa lung residence, whence Rig 'dzin Padma dbang rgyal rdo rje proceeded directly to gTsang and Sikkim in order to perform the rituals requested by the Tibetan government. These activities need to be seen in the context of the so-called Tibetan-Dogra war, which lasted from 1834 to 1842, and included military engagements between the invading troops of the Dogra Raja of Jammu and Tibetan forces at mNga' ris skor gsum in Western Tibet. Kun bzang Nges don klong yangs was in contact with his teacher during this period, and his memoirs mention that Rig 'dzin Padma dbang rgyal rdo rje—described earlier as the preceptor of the tenth king of Sikkim—asked him to accept the position of *bla mchod* of gTsug phud rnam rgyal, and thence to head on to 'Bras mo ljongs.¹¹

Once again it was mainly the teaching tradition of sMin grol gling—during this period, represented by 'Gyur med 'Phrin las rnam rgyal and Sangs rgyas Kun dga' mchog, respectively the fifth and seventh throne-holders of the rNying ma pa monastery in Central Tibet—that were spread by Rig 'dzin Padma dbang rgyal rdo rje.¹² Concerning the incarnation lineage of which he was a part, it is stated

¹¹ The studies under Rig 'dzin Padma dbang rgyal rdo rje are described in Kun bzang Nges don klong yangs: *sGra dbyangs lha mo'i gling bu*, pp. 335.1-343.5, and *Ngo mtshar dpyid kyi rgyal mo'i rang sgra*, pp. 177.1-178.2. An overview of the main events of the Tibetan-Dogra war is given in Tsepon W.D. Shakabpa (1967:176-180); for the written correspondence that formed the basis of a settlement between Ladakh and Tibet see (*ibid.*: 327-328). See also the chapter titled “War between Tibet and Ladvags” (*bod dang / la dvags dmag 'khrug skor*) in Zhva sgab pa dBang phyug bde ldan: *Blo gsar byung ba dga' ba'i rol mtsho*, vol. 2, pp. 3.10-11.5. The exchange of letters between Rig 'dzin Padma dbang rgyal rdo rje and his disciple, and the invitation to visit Sikkim, are noted in Kun bzang Nges don klong yangs: *sGra dbyangs lha mo'i gling bu*, p. 349.4-6. The site of the teacher's demise is given in the text as sTod gangs blon chen; see *ibid.*, p. 359.5-6. This epithet applies—along with “lord minister” (*jo bo blon po*)—to Mount Makalu in the eastern part of the Nepalese Himalayas, close to Mount Everest; see Diemberger (1997: 283-284).

¹² For the place of 'Gyur med 'Phrin las rnam rgyal and Sangs rgyas Kun dga' mchog within the succession of throne-holders of sMin grol gling, see bsTan pa'i sgron me: *O rgyan smin grol gling gyi dkar chag*, p. 132.4-8. Their lineage of the spoken teaching tradition spans the continuous family line of the gNyos clan, i.e. the linear descendants of Rig 'dzin gTer bdag gling pa; see Dudjom Rinpoche (1991: 733).

that it can be traced back to the Buddhist master Hūṃkara, having begun with the “brother” (*sku mched*) of lHa btsun Nam mkha’ ’jigs med called Khrag ’thung Hūṃkara (or Khrag ’thung Hūṃ dkar); this is none other than the above-mentioned Rig ’dzin lhun grub. The name of the member in the lineage immediately before Rig ’dzin Padma dbang rgyal rdo rje is given in the historiographical source as rDo rje Chos dbyings yongs grol, it being stated that by then there already existed a succession of “incarnations of Rig ’dzin lhun grub.”

This can only mean that at least one person came between Rig ’dzin lhun grub and rDo rje Chos dbyings yongs grol, and in fact this hypothesis is corroborated by a document providing a complete list of the individual members of the incarnation lineage going back to the nephew (or, in later sources, brother) of lHa btsun Nam mkha’ ’jigs med. According to this source, the person in question was known as O rgyan gSang sngags bstan ’dzin. At the same time, we are informed of the name of the next member of the lineage after Rig ’dzin Padma dbang rgyal rdo rje; he is called ’Gyur med Padma tshul khirms (d. 1895). Trained again in sMin grol gling, he was still alive when the written history of the rNying ma pa school was completed in 1882. In order to provide a complete overview of this incarnation lineage, the document will be presented in Appendix I. Several writings of individual members of the lineage of the so-called dPal ri sPru skus have also become available, and these will be presented in Appendix II (including those of O rgyan rnam grol dbang po, the disciple of Rig ’dzin Padma dbang rgyal rdo rje).

5. *The gNas yig of Blon chen gangs*

Rig ’dzin Padma dbang rgyal rdo rje, who can be considered to be the Fourth dPal ri sPrul sku, taught in the final phase of his life in Va lung (present-day Walung in the Sikkim-Nepalese borderlands), a region of “arable land” (*zhing sa*), and passed away near Mt. Makalu. We have now to turn to the monastic sites associated with the lineage in these Himalayan valleys in or bordering on south-western Tibet. The document used for reconstructing the lineage refers on two occasions to the “Glacier of the Minister” (*blon pa’i gangs*) and provides the alternative name of [g]Zar mo ri as well, which could be translated as “Steep Mountain”. The monastery located in the wider surroundings of Mt. Makalu is called dPal ri Theg chen gling, and was obviously the seat of the dPal ri sPrul skus in the region.

A guidebook to this monastery, known as a “history of the sacred site” (*gnas kyi lo rgyus*), has survived, and it is thus possible to form a

general idea of the foundation myth and the subsequent development of this institution. As the full title implies, the place is regarded as a former “site of spiritual realisation” (*sgrub gnas*) of the great adept Padmasambhava. Basing himself on older literary sources, the author presents [g]Zar mo ri as lying in the centre of four other sacred sites topographically related to it: it lies south-west of dPal Sa skya, north-west of ’Bras mo ljongs (i.e. Sikkim), north-east of mKhan pa lung, and south-east of Tsib ri. The text also contains an explanation of the name “Glacier of the Minister,” linking it with the account of King Khyi kha ra thod and his son Blon po’i mchog byed. It states that Padmasambhava stayed there for a period of two months, for the most part at a cave known as bKa’ brgyad phug mo che.¹³

After an idealised description of the landscape—the sacred springs, naturally formed stūpas and various caves encountered there (including the so-called ’Od gsal phug gong ma, frequented by the “Madman from Kong [po]” (*kong smyon*) lHa btsun Nam mkha’ ’jigs med)—the text has a separate chapter on the foundation of the monastery itself. The latter had originally been established as a “community for spiritual realisation” (*sgrub sde*) by ’Phyong rgyas ras chen (seventeenth century), a native of dBus and a disciple of lHa btsun Nam mkha’ ’jigs med; according to the guidebook, ’Phyong rgyas ras chen was following a direct order of his master when he founded the site. Faced with an influx of many disciples, it was eventually divided into two monastic settlements, called Shar gling and Nub gling. Later it was administered by O rgyan gSang sngags bstan ’dzin and rDo rje Chos dbyings yongs grol, respectively the second and third dPal ri sPrul sku; they are called in the text the reincarnations of Hūm chen kara Rig ’dzin lhun grub, the “nephew of

¹³ For the passage relating to the topography and account of [g]Zar mo ri, see Chos dbang rig ’dzin: *Dad ldan blo gsal rnams kyi gzigs lo*, fols. 10b/2-11a/6. The importance of the figure of Khyi kha ra thod (“Dog Face, Goat Neck”) and his later expulsion in the context of the opening of Himalayan hidden lands is described in Aris (1979: 60-82). Chos dbang rig ’dzin, the author of the text, again followed the tradition of sMin grol gling and can be identified as the Sixth dPal ri sPrul sku; see *Dad ldan blo gsal rnams kyi gzigs lo*, fol. 21b/2-6 (*de ltar gnas yig gsal bar bkod pa ’di nyid smin gling chos ’bangs su gtogs pa dpal sprul rig ’dzin chos dbang ming pas snga sor gnas yig rmying pa gzhir bzhag gsal kha phran bus brgyan ste bkod pa yin cing / gnas ’di’i lo rgyus khungs ma gzhan dag yod shag kyang phran gyi mthong thos ma myong bas re zhig ’di tsam las zhu tshod ma thing zhing tshig don ’gal ’char ’dug na bzod par dgongs la tshangs par mdzod cig*). A prayer for the long life of Chos dbang rig ’dzin written by his contemporary, the rDza rong phu Bla ma Ngag dbang bsTan ’dzin nor bu (1867-1940) has survived; see id.: *bDen pa’i sgra dbyangs*.

IHa btun [Nam mkha' 'jigs med]" (*Iha btsun mched dbon*). It is further stated that rDo rje Chos dbyings yongs grol was himself the nephew of Mi dbang bSod nams stobs rgyas (1689-1747), who played a key role in the civil war in Tibet of the years 1727-28 by restoring political stability to the country. It was from this uncle and the Seventh Dalai Bla ma sKal bzang rgya mtsho (1708-1757) that the monastery of the lineage of the dPal ri sPrul skus received a "religious endowment" (*chos gzhis*), from which point onwards it was known as dPal ri Theg chen gling. To this monastic site were attached "branch monasteries" (*dgon lag*) including Blon chen Phun tshogs bSam gtan gling. Under Rig 'dzin Padma dbang rgyal rdo rje and 'Gyur med Padma tshul khriims, respectively the Fourth and Fifth dPal ri sPrul skus, this latter monastery was lavishly furnished with religious statues and books, and during the time of the fifth throne-holder a special temple was erected for housing a complete *bKa' 'gyur* together with a xylograph edition of the *rNying ma rgyud 'bum*.¹⁴

To judge by these details, the lineage of the dPal ri sPrul skus had, from O rgyan gSang sngags bstan 'dzin onwards, its main residence at dPal ri Theg chen gling, and branch monasteries in southern Tibet strung out from the Sikkim-Nepalese borderlands to [IHo brag] IHa lung in the east. While the original seat of the lineage, dPal ri dgon pa, was located in gTsang, after the death of Rig 'dzin lhun grub the following incarnations appear to have been mainly active in the southern border regions of Tibet.

6. *The Documents from Walung*

Constructing a new religious building meant, among other things, setting down in writing the history of the temple and cataloguing its

¹⁴ Two sections of the text describe the sacred landscape of the site and the history of dPal ri Theg chen gling and Blon chen Phun tshogs bSam gtan gling; see Chos dbang rig 'dzin: *Dad ldan blo gsal rnam kyi gzigs lo*, fols. 11a/6-16b/2 (*mtshan nyid dang rang byon bzhugs tshul*), and fols. 16b/2-19a/2 (*sgrub sde rten gyi lo rgyus*). 'Phyong rgyas ras chen was also actively engaged in other regions of south-western Tibet in transmitting the teachings of IHa btsun Nam mkha' 'jigs med; concerning his contacts with mDo chen pa Nor bu bde chen (b. 1617) and O rgyan dPal bzang (1617-1677) in Mang yul Gung thang and the transmissions he gave according to the writings of these two religious teachers, see Ehrhard (2008: 103-104). On the civil war in Tibet, the rise of Mi dbang bSod nams stobs rgyas to political power, and his rule, which lasted from 1735 to 1747, see Petech (1972: 122-197) and Tshen ring dbang rgyal: *'Jig rten kun tu dga' ba'i gtam*, pp. 197. 16 ff.; there is no information on a nephew of the ruler and the ruler's support of the monastery of dPal ri Theg chen gling in this second source.

sacred objects—statues, religious books and so forth. Such a document has survived, from the pen of 'Gyur med Padma tshul khrim, written down during the establishment of the temple, which came to be known as the bKa' 'gyur lha khang. The historical part of the work contains the same details as recorded in the guidebook to Blon chen gangs, the region being described as “the upper part of [g]Zar, enclosed by the Glacier of the Great Minister (i.e. Mt. Makalu)” (*zar phu blon chen gangs kyi rva ba*). The importance of 'Phyong rgyas ras chen is highlighted, as is—for his having produced many religious artefacts—Rig 'dzin Padma dbang rgyal rdo rje. Then follows the construction of the bKa' 'gyur lha khang by the latter's incarnation, who also composed the register when the construction work was completed.¹⁵

The same kind of register is available for another monastic site that was under the administration of the incarnation lineage of the dPal ri sPrul skus. The name of this institution is bDe chen dgon or bDe skyid chos gling, located still further south within the area where the borders of Tibet, Sikkim and Nepal now converge. The site was special not only in virtue of its physical location but also in a religious sense; this is reflected in the introductory part of the document:

This [monastery of] bDe skyid chos gling is a place in the hidden land of Sha lba lung [= Walung], which is a branch sacred site of 'Bras mo ljongs, [itself] a pilgrimage site blessed by the mighty Jina Padmakara [= Padmasambhava] [as] the hidden land known as Kamaru, [which is one] of the twenty-four [pīṭha] countries and [is] praised as Be'u ra Valley in the *Ratnakutasūtra* by our teacher Ādityabandhu [Śākyamuni Buddha], the all-knowing son of Śudhodana.

During the successive arrival of the line of the dPal ri incarnations in the early period, when [the area] was governed by the Sikkimese—the dance of [emanations of] lHa dbon Rig 'dzin lhun grub, the second of the pair of two brothers of lHa btsun Kun bzang rnam rgyal [= lHa btsun Nam mkha' 'jigs med], he who opened the door of the sacred site 'Bras [mo] ljongs—[and to be precise,] during the time of Rig 'dzin Padma dbang rgyal rdo rje, the headmen of lBa lung [= Walung] and all the ordained and laypersons of the five districts [signed] an

¹⁵ See 'Gyur med Padma tshul khrim: *sGo 'phar 'byed pa'i lde mig*. This register should be compared with another one bearing the title *Gangs blon lhun grub 'od gsal bde chen yang rtse'i gan dho la rten pa bcas gsar bzhengs gi dkar chag srid zhi'i dge legs sgo 'phar phyed ba'i (= 'byed pa'i) sde mig (= lde mig)*, 15 fols., NGMPP reel-no. AT 105/3. The author gives his name as dPal sprul Padma bdud 'dul dbang phyug, which may be an alternative name of the Fifth dPal ri sPrul sku 'Gyur med Padma tshul khrim.

agreement, requesting assistance [of the sort] given by the [Sikkimese] government as of old.

During the time of the Highest Refuge 'Gyur med Padma tshul khirms, the king of Gorkha issued a series of pronouncements in the form of land tenure documents, to the effect that [the former] right to own [both] the internal [and] external [property] of the monastery bDe skyid chos gling would be protected. In the wood [female] sheep year [= 1895] the Lord of Refuge 'Gyur med Padma tshul khirms dissolved his mind into the Dharmadhatu and later, in the fire [male] monkey year [= 1896], a true manager and storekeeper known to all, [who] was involved in the memorial service [for the deceased teacher] [ceased to] live permanently [there] with his family and therefore a representative had to be nominated. On top of that, the [once] freshly produced account book for the three [kinds of] sacred items (i.e. statues, books and stūpas), offering substances [and] furniture had become greatly tattered during its many years [of use].

Now, therefore, in the iron [female] bird [year] [= 1921], when the Refuge, the Precious Reincarnation [= Chos dbang rig 'dzin]—the teacher and his entourage—comes personally to the residence of bDe [skyid] chos[gling] for the purpose of closely inspecting everything, including the sacred items representing the body, speech [and] mind [of the Buddha], and in order to delight the custodians, the monks responsible for the offerings and the general assembly [of the monastic community]—in their succession of old and new—two account books have been set up [new], which are similar [in content], like mother and son.¹⁶

¹⁶ See Anonymous: *Yid ches dngos kun gsal ba'i adarśa*, fols. 1a-3b (*de yang bdag cag gi ston nyi ma'i gnyen nam kun mkhyen zas gtsang sras pos mdo sde dkon brtsegs las be'u ra zhes lung du bsngags cing yul nyer bzhi las ka ma ru zhes rgyal dbang padma karas sbas yul du byin gyis brlabs pa'i gnas chen 'bras mo gshongs kyi gnas lag sbas yul sha lba lung gi sti gnas bde skyid chos gling 'di nyid / 'bras mo ljong (= ljongs) gnas sgo 'byed par mdzad po lha btsun kun bzang rnam rgyal gyi mched gnyis lha dbon rig 'dzin lhun grub gyi zlos gar dpal ri sku 'phreng rim byon nas sngar dus 'bras ljongs pa'i skabs nas 'dzin skyongs mdzad mus kar / rig 'dzin padma dbang rgyal rdo rje'i sku dus lba lung 'go dpon rnam dang yul 'tsho lnga'i khongs ser skya drag gzhan tshang nas sngar lam 'dzin skyongs gnang grogs zhus pa'i gan yig dang / skyabs mchog 'gyur med padma tshul khirms kyi sku dus gor rgyal mchog nas gtsan tshigs ru bka' rim stsal 'bru don dgon bde skyid chos gling gi phyi nang 'dzin dbang bdag thob skyongs mus gyis shing lug lo skyabs rje 'gyur med padma tshul khirms dgongs pa chos dbyings su thims rjes me sbrel lo las 'dzin mdzad pa kun shes ngo ma dgongs rdzogs mchos sprin dang 'brel dgon gnas su ngo sbyor (= 'byor) gyi ngo ma gtan sdod med stabs ngo tshab bkod mngags thog rten gsum mchod rdzas 'dzin chas sogs sprod gsher (= bsher) gyi gtan (=rten) deb gsar bskrun byas pa lo mang hrul songs ches gshis / da lam lcags bya skyabs sprul rin po che ston 'khor bde chos gdan sar ngo phebs kyi rten pa sku gsung thugs rten 'dzin chas sogs gang cir zhib gsher (= bsher) gyi slad dkon gnyer / mchod dpon / spyi mo bcas gsar rnying*

7. Conclusions

The foregoing description of the monastery of bDe skyid chos gling shows quite clearly that Walung was at different periods under the political administration of both Sikkim and Nepal, a situation which has to be seen in the context of the expansion of the Gorkha state (the earliest Gorkha invasion is dated from the year 1774). This expansion led to the Sino-Nepalese war in the years 1788-1792, with East Nepal and Sikkim being in great turmoil from 1791 till the peace agreement signed between the Gorkha ruler and the Manchu sovereign in the following year. The Nepal-Sikkim boundary has been a matter of dispute ever since, Sikkim having lost a lot of its territory to Nepal.

In view of the contents of the document from bDe skyid chos gling, it should be pointed out that Sikkimese governance was regarded as the “old way” (*sngar lam*) of political rule in contrast to the one imposed by the Gorkha government. This earlier custom implies that the Tibetan monastery was administered by religious masters with close ties to both the Sikkimese court and the central government in Lhasa, as witnessed in the case of the Fourth dPal ri sPrul sku Padma dbang rgyal rdo rje, who served as preceptor to King gTsong phud rnam rgyal and performed ritual acts for the protection of the border regions on behalf of the dGa’ ldan pho brang government. This changed with the integration of Walung into the Nepalese state, which was achieved—as is generally accepted—by relying on the local authority of “headmen” (*’go ba*), the same ones mentioned in the document from Walung. The peculiar status of the monastery—as lying within the sphere of interest of Tibet, Sikkim and Nepal—is still to be witnessed in modern times, as reported in an eyewitness account from the year 1981; at that time bDe skyid chos gling was under permanent surveillance by Nepalese officials, with tensions running high between them and the Tibetan population of Walung.¹⁷

rims par spro len bde phyir gtam (= rten) deb ma bu ’dra gnyis su bkod par). One of the two mentioned texts has survived; see anonymous: *rTen gsum ma deb*. These kind of registers, which list the movable property of a monastery at the time of its passing over from one incarnation to the next, can be compared to the so-called “conveyance documents” (*sprod deb*) used as part of Tibetan government practice; see Cueppers (2007:13).

¹⁷ For an overview of the expansion of the Gorkha state to the west and the conquests of East Nepal and Sikkim, see Pradhan (1991: 106-149). There were several reasons for the Sino-Nepalese war, among them the annoyance felt by the Gorkha rulers over an agreement that had been signed between Tibet and Sikkim after the Gorkha state, in collusion with the Bhutanese, invaded the neighbouring

The document further attests that bDe skyid chos gling was under the religious administration of the incarnation lineage of the dPal ri sPrul skus. Rig 'dzin Padma dbang rgyal rdo rje in particular must have contributed in the first decades of the nineteenth century towards the development of the monastery. The significance of the place where bDe skyid chos gling had been erected has to be seen in connection with the trade route which passed along the upper reaches of the Tamur Valley. The important strategic role of this pass is known from the many disputes between Tibet and Nepal from 1750 onwards. It was there that the agreement between the Gorkha leaders and the Tibetan government was signed on the eve of the Sino-Nepalese war.

It has already been observed that sacred sites in Himalayan regions are often to be found in the vicinity of a trade route. This means that the emergence of a "hidden land" (*sbas yul*) in a specific geographical area had a strong impact on patterns of economic and cultural exchange. The wording of the document is quite explicit in this regard, for it presents the region of Walung as a hidden valley and links it with 'Bras mo ljongs, describing it as a "branch sacred site" (*gnas lag*) of the latter region. This connection was all the closer for the incarnation lineage of Rig 'dzin lhun grub being responsible for the spiritual welfare of the inhabitants of the minor hidden land of Walung, in the same way as lHa btsun Nam mkha' 'jigs med and his successors had been active in Sikkim.¹⁸

Like the lHa btsun sPrul kus, the incarnation lineage of the dPal ri sPrul skus was active in Sikkim and valleys neighbouring it, and with the help of the literary sources presented here it has been possible to

Himalayan kingdom. The Sikkimese had asked the Tibetan government for help, and this resulted in the Walung agreement, which only made the Gorkha leaders look for an excuse to march into Tibet; see Ehrhard (2007b: 118). For the eyewitness account of the situation in bDe skyid chos gling in 1981, see Steinmann (1988: 191). See also Diemberger (1994: 149) regarding the community of Gunsu, another region bordering on Sikkim under local headmen from Walung, shared with the latter region its peculiar position between Tibet, Nepal and Sikkim, and was likewise integrated into the nation-state of Nepal.

¹⁸ The trade through Walung and the importance of the pass for trans-Himalayan trade is described by Schrader (1988: 264-277). It should be noted that the privileges of local headmen were recognized by the Nepalese government from 1841 onwards (i.e. after the death of Rig 'dzin Padma dbang rgyal rdo rje); see *ibid.*: 272-273. Soon afterwards, in the year 1848, Joseph Dalton Hooker (1817-1911) reached Walung and Gunsu as the first European visitor who would leave descriptions of these places and their settlements; see Hooker (1987: 206) and Robertson (1998: 67-68). For the 'hidden valley' as conceptually a religious space, and for further examples of such sanctuaries in the vicinity of Himalayan trade routes, see Ehrhard (2001: 238-239).

follow their activities from Central Tibet through the Mt. Makalu region up to Walung in the Nepalese Himalayas. Although we now possess an overview of the individual members of this lineage and their writings, a complete history still remains to be written. At least we are now well informed about the activities of the Fourth dPal ri sPrul sku Rig 'dzin Padma dbang rgyal rdo rje, who is especially remembered for having “turned the wheel of the Dharma in Zhing sa Va lung.”

APPENDICES

The materials presented here are part of the collection of the Tibetan texts originally kept in the Nepalese National Museum, Chauni, and afterwards transferred to the Nepalese National Archives (Ramshah Path) and microfilmed by the Nepal-German Manuscript Preservation Project (NGMPP). Their place of origin is the monastery of bDe skyid chos gling in Walung. A complete evaluation of the contents of this Buddhist library is currently in progress.

[1]

The document which contains a eulogy of the incarnation lineage of the dPal ri sPrul skus from dPal ri Theg chen gling in the Makalu region has no title, and was microfilmed by the NGMPP under reel-no. AT 172/7. It has also no folio numbers and may well have been written as an introduction to an inventory of the religious items contained in the monastery. It should be noted that the individual that appears after rDo rje Hūm mdzad (i.e. Hūm kara), the founder of the lineage, the “Dharma minister” (*chos blon*) is Padma Gung btsan. The latter, known for his support of the Buddhist religion at the court of King Khri Srong lde'u btsan, played an important role in the establishment of other incarnation lineages, including that of the Yol mo ba sPrul skus; see Ehrhard (2007a: 27). The underlined passages are written in red ink in the document.

zla med stobs bcu'i dpal mnga' rdzogs sangs rgyas /
zab zhi spros pa kun bral dam pa'i chos /
nyan rang byang sems 'phags chen chos pa'i tshogs /
mchog gsum rin chen gtsug na mdzes gyur shig /

snang stong zung du 'jug pa lhun grub sku /
gsal stong brjod pa dang bral skye med gsung /
bde stong gnyug ma'i ye shes rdo rje'i thugs /
rig stong rang byung don gyi bla mar 'dud /

gdod nas dri bral 'pho med chos sku'i mkhar /
lhun grub 'du ma byas pa'i 'od phung brdal /
bsam yas sgyu 'phrul drva ba'i dkyil 'khor che /
spro bsdu'i byed po rdo rje sems dpar sngags /

*gnyug ma mi gshigs sder rnon cher bsgrad pas /
rtag chad mtha' bzhi'i va skyes mthar bskard cing /
rang byung rig pa'i rtsal chen yongs rdzogs pa /
gdengs lnga'i dbang po rdo rje hūm mdzad mchod /*

*bsil ljongs phan bde'i gzhi rtsa lha'i me tog /
nag bsnums lcang lo'i rtse mor rab bcings nas /
lugs gnyis khirms kyi gser 'khor drangs po ru /
bsgyur mdzad chos blon padma'i gung btsan rgyal /*

*ma dag 'khor ba'i snang tshul ji snyed pa /
ma spangs sgyu 'phrul drva ba'i phyag rgya ru /
yongs gzigs rig 'dzin kun gyi gtsug rgyan mchog /
rnam bzhi'i 'phrin las lhun gyi grub der bsngags /*

*o rgyan gu ru'i thugs bcud gdams pa'i mdzod /
gsang chen sngags kyi rgyud sde rgya mtsho'i bstan /
'dzin mkhas gser phreng rim byon tshogs bcas la /
dad gsum rnam par spro ba'i phyag gis btud /*

*chos dbyings rig pa'i glog phreng rab bar bas /
chos can gnyis 'dzin rmag rum 'thib po'i mun /
yongs su grol bas snang grags lha dang sngags /
dbang po'i rgyan du gyur la ngo mtshar rmad /*

*zab las ches zab smin grol ku mu ta tshal /
khyod thugs ri bo 'dzin pas rab bzhad nas /
skal bzang yid kyi ral pa'i rtser bkod mdzad /
rig 'dzin padma dbang rgyal spyi bos mchod /*

*mi 'gyur 'pho med bde chen rdo rje'i rtser /
chos zad rig pa'i mkha' la yongs bsgyur mkhas /
gsang chen 'od gsal snying po'i bstan 'dzin mchog /
bka' drin zla med pad ma tshul khirms rgyal /*

*tshogs zung chu gter rlabs phre ri dbang rtser /
phyar las legs grub dpal ri padma 'od /
theg mchog rdzogs pa chen po'i chos gra che /
gling bzhi'i rgyan du lham mer gsal gyur cig /*

*padma kā ra'i thugs rje'i byin rlabs kyi /
gzhi 'od rtag 'bar rtsa gsum sprin bzhin gtibs /
skal ldan rgyud la ye shes 'char byed gnas /
blon po gangs zhes bsngags pa'i me tog 'thor /*

*sngon tshe rgyal ba'i snyan sngar bstan pa dang /
che 'dzin skyongs bar zhal bzhes rgyud gsum gyi /
dam can tshogs dang dpal 'bar ma ning nag /
zhing skyongs ma mor bcas pas 'dir dgongs shig /*

*de ltar smin grol bdud rtsi'i chu rgyun che /
 'byung ba'i sgo gcig dpal ri theg chen gling dang /
 zar mo'i ri'i blon po gangs zhes pa'i /
 deb ther zla ba'i rdzing bu 'di na ldar /*

*zhes mchod par brjod pa tshig 'phreng ma ra ba'i me tog bsil ma 'thor te gang brjod
 par bya ba /*

[2]

The following title list presents the writings of the first four members of the incarnation lineage of the dPal ri sPul sku up to Rig 'dzin Padma dbang rgyal rdo rje and his disciple O rgyan nam grol dbang po. This is a preliminary survey, containing as it does only those manuscripts available in the above-mentioned collection; it is hoped that more writings of these teachers and the following dPal ri sPul sku will surface in the future.

Rig 'dzin lhun grub, 1st dPal ri sPul sku (d. 1650)

*dGongs gter thugs kyi klong gsal las tshe dpag med dkar po / dbang lung khrid bla
 ma'i rnal 'byor sogs gang la 'jug kyang yongs ba'i sngon 'gro rim pa, 12 fols.,
 NGMPP reel-no. AT 67/4*

_____ *sGyu 'phrul glu'i phreng ba mngon sum ye shes kyi 'khor lo, 30 fols.,
 NGMPP reel-no. AT 86/2*

_____ *Zhal gdams kyi rim pa nam grol thar gling gi shing rta, 131 fols., NGMPP
 reel-no. AT 80/1*

_____ *Rig 'dzin chen po nam mkha' 'jigs med kyi zhal gdams dang gsung mgur
 kha 'thor phyogs gcig tu bsdus pa, 31 fols., NGMPP reel-no. AT 109/10 (compiled by
 Rig 'dzin lhun grub)*

O rgyan gsang sngags bstan 'dzin, 2nd dPal ri sPul sku

*dKon mchog spyi 'dus kyi bla bsgrub zin bris dran gsal, 17 fols., NGMPP reel-no. AT
 60/21*

_____ *bKa' rdzogs pa chen po yang zab dkon mchog spyi 'dus kyi khrid yig, 10
 fols., NGMPP reel-no. AT 61/1*

_____ *rJe btsun khros ma nag mo'i bsnyen yig nyung bsdus sgron me, 5 fols.,
 NGMPP reel-no. AT 84/2*

_____ *sNying gam 'phrin glur phul ba, 10 fols., NGMPP reel-no. AT 103/10*

_____ *dPal ri gnas bdag 'bar ba mched bdun gyi mchod 'phreng 'dod dgu'i char
 'bab, 3 fols., NGMPP reel-no. AT 66/7*

_____ *Phur pa spu gri'i las mtha' bsreg pa'i bsngags dregs 'joms pa'i stag gdong
 gi me dpung, 7 fols., NGMPP reel-no. AT 97/17*

_____ *Yang zab dkon mchog spyi 'dus kyi sgrub chen zin bris yid bzhin gter
 mdzod, 22 fols., NGMPP reel-no. AT 61/2*

_____ *Seng gdong 'jug dang po zhi rgyas dbang drag, 3 fols., NGMPP reel-no. AT
 85/7*

rDo rje Chos dbying yongs grol, 3rd dPal ri sPul sku

*rJe btsun khros ma nag mo'i bsnyen yig nyung bsdus sgron me, 5 fols., NGMPP reel-
 no. AT 85/7 (same title as one of the works of the O rgyan gsang sngags bstan 'dzin)*

Rig 'dzin Padma dbang rgyal rdo rje (1779-1841), 4th dPal ri sPrul sku

rGya po dkar po drug mdos, 4 fols., NGMPP reel-no. AT 161/6

_____ *gTer bdag 'dod don kun ster*, 6 fols., NGMPP reel-no. AT 161/6

_____ *bDe gshegs kun 'dus kyi bskyed rdzogs kyi 'khrid nyams len byed tshul gyi zin bris zur 'debs*, 3 fols., NGMPP reel-no. AT 100/19

_____ *bDe gshegs kun 'dus las mtshan mo'i rnal 'byor zab gnad zur gsal sogs zhal shes zin bris bskor rnams*, 9 fols., NGMPP reel-no. AT 100/19

_____ *rDo rje snying po sprin (= 'phrin) gyi thol glu'i dngos gzhi lha 'khrid bskor rdo rje 'chang gi dgongs brgyan*, 38 fols., NGMPP reel-no. AT 159/1

_____ *Phyag rdor gyi gzungs / gter gsar gshin rje dregs 'joms kyi dbang bshad*, 12 fols., NGMPP reel-no. AT 67/6

_____ *Zhi khro nges don snying po'i sgrub chen gyi lag len chu 'babs ltas mchog tu bkod pa*, NGMPP reel-no. AT 137/4

_____ *gSang mtshan thugs kyi sgrub pa las / rdo rje rnams (= rnam) 'joms kyi khrigs su sdebs pa*, 15 fols., NGMPP reel-no. AT 97/5

_____ *Las 'brel gnyen po lha gsum gyi rgyun khyer*, 3 fols., NGMPP reel-no. AT 145/8

O rgyan rnam grol dbang po, lCags sbug Rin po che

bCom ldan 'das rdo rje phur bu yang gsang spu gri 'bar ba'i sgrub chen dngos grub dga' ston gyi gsal byed lhan thabs rig 'dzin dgongs rgyan, 58 fols., NGMPP reel-no. AT 120/4

_____ *bsNyen bsgrub spyi la gces pa'i man ngag*, 19 fols., NGMPP reel-no. AT 147/17

_____ *sDe dpon gsum bcu'i gsol mchod / dregs pa sde dpon sum bcu'i gsol kha*, 47 fols., NGMPP reel-no. AT 136/11

_____ *Byang gter gsang ba rmad byung gi gcod kyi ngag 'don khol du byung ba*, 5 fols., NGMPP reel-no. AT 124/6

_____ *Byang gter phur pa lha nag gi phur pa'i rgyu tshad dbyibs bstan pa'i gzhung las zur bkod*, 2 fols., NGMPP reel-no. AT 124/6

_____ *Byed grol gser gyi lde mig gi rtsa gzhung las byang ltor mtshams 'byor khog sgrig lag len*, 23 fols., NGMPP reel-no. AT 89/9

_____ *sBas mtha'i ri khrod du 'dug tshul dang rnams (= rnam) kun rang brgyud (= rgyud) chos dang bsre tshul gyi bslab bya zhal gyi gdams pa'i nying khu gsang ba bdud rtsi thig le*, 5 fols., NGMPP reel-no. AT 82/7

_____ *Rakta sbyor tshad 'ga' rga'i chu rgyun*, 2 fols., NGMPP reel-no. AT 98/18

BIBLIOGRAPHY

Tibetan Texts

Anonymous

Wa lung bde chos dgon gyi rten gsum mchod cha 'dzin chos sogs gang na ci yod rnams thor gar mi 'byung ba'i slad du 'debs (= deb) su bkod pa [yid ches dngos kun gsal ba'i a dar sa], 20 fols., NGMPP reel-no. AT 89/3.

_____ *Wa lung bde chos kyi rtsib (= zhib) bshod (= bshed) rten gsung (= gsum) ma 'debs (= deb)*, 11 fols., NGMPP reel-no. AT 172/6.

Kun bzang Nges don klong yangs, 6th Dog sprul (b. 1804)
Bod du byung ba'i gsang sngags snga 'gyur gyi bstan 'dzin skye mchog rim byon gyi rnam thar [nor bu'i do shal], 186 fols., Dalhousie: Damchoe Sangpo, 1975.

_____ *Rig 'dzin rdo rje gsang ba rtsal gyi rtogs par brjod pa [sgra dbyangs lha mo'i gling bu]*, 185 fols., In "Lives of Lha btsun Kun dga' chos kyi rgya mtsho and Rdo rje gsang ba rtsal." Darjeeling: Kargyud Sungrab Nyamso Khang, 1974, pp. 199-575.

_____ *Rig 'dzin rdo rje gsang ba rtsal gyi gsang ba'i rtogs brjod [ngo mtshar dpyid kyi rgyal mo'i rang sgra]*, 15 fols., *ibid.*, pp. 169-197.

Khyung po ras pa (b. 1715)
rJe btsun mi 'gyur dpal gyi sgron ma'i rnam thar [dad pa'i gdung sel], 119 fols., Thimphu: National Library of Bhutan, 1984.

'Gyur med Padma tshul khriims, 5th dPal ri sPrul sku (d. 1895)
Gangs blon phun tshogs bsam gling gi lha khang bla brang gzim chog gsar gzhengs (= bzhengs) gi rten gsum mchod rdzas dang bcas pa'i debs (= deb) gter (= ter) legs byas [sgo 'phar 'byed pa'i lde mig], 5 fols., NGMPP reel-no. AT 89/2.

Ngag dbang bsTan 'dzin nor bu, rDza rong phu Bla ma (1867-1940)
dPal ri mchog sprul chos dbang rig 'dzin gi zhabs brtan gsol 'debs [bden pa'i sgra dbyangs], 2 fols. (xylograph), NGMPP reel-no. L 317/13.

Ngag dbang Blo bzang rgya mtsho, 5th Dalai Bla ma (1617-1682)
sMon lam shis brjid brtan bzhugs sogs kyi tshigs su bcad pa [rab dkar dge ba'i chu klung], 308 & 111 fols. In "Collected Works of the Vth Dalai Bla ma Ngag dbang Blo bzang rgya mtsho", vol. 21. Gangtok: Sikkim Research Institute of Tibetology, 1993, pp. 3-839.

_____ *Za hor gyi ban de ngag dbang blo bzang rgya mtsho'i 'di snang 'khrul pa'i rol rtsed rtogs brjod kyi tshul du bkod pa [du kū la'i gos bzang]*, 3 vols., 718, 532 & 454 pp., Lhasa: Bod ljongs mi dmangs dpe skrun khang, 1989-1991.

_____ *Zur thams cad mkhyen pa chos dbyings rang grol gyi rnam thar [theg mchog bstan pa'i shing rta]*, 121 fols. In "Collected Works of the Vth Dalai Bla ma Ngag dbang Blo bzang rgya mtsho", vol. 9. Gangtok: Sikkim Research Institute of Tibetology, 1992, pp. 3-243.

Chos dbang, mKhan po (b. 1955)
sBas yul 'bras mo ljongs kyi chos srid dang 'brel ba'i rgyal rabs lo rgyus [bden don kun gsal me long], 400 pp., Gangtok: Namgyal Institute of Tibetology, 2003.

Chos dbang rig 'dzin, 6th dPal ri sPrul sku (19th/20th cent.)
Zar mo ri zhes grags pa gu ru'i sgrub gnas 'di nyid kyi gnas kyi lo rgyus gsal bar bkod pa dvangs shel me long bzhin ras snyon [dad ldan blo gsal rnams kyi gzigs lo], 21 fols., n.p., n.d.

'Jigs med dpa' bo, 3rd lHa btsun sPrul sku (b. 1682)
rDzogs chen rig 'dzin 'jigs med dpa' bo'i bka' 'bum [mthong grol chen mo], 429 fols. Gangtok: Dzongsar Khyentse Labrang, 1983.

bsTan pa'i sgron me (b. 1932)

O rgyan smin grol gling gi dkar chag, 387 pp. Zi ling: Khrung go'i bod kyi shes rig dpe skrun khang, 1992.

Nam mkha' 'jigs med, 1st lHa btsun sPrul sku (1597-1653)

mKha' spyod sprul pa'i pho brang 'bras mo gshongs su har sangs sgyu ma'i rol rtsed kyi nyul ba'i lam yig [rab gsal nyin byed 'bar ba'i 'od stong], 151 fols. In "The Collected Writings of lHa btsun Nam mkha' 'jigs med", vol. 3, Darjeeling: Lama Gyurdrag & Taklung Tsetrul Rinpoche Pema Wangyal, 1974, pp. 425-725.

_____ *rNal 'byor gyi dbang phyug nam mkha' 'jigs med kyi rigs dbon thugs sras kyi mthu bo [khrag 'thung hūm dkar gyi gsang ba'i rnam thar]*, 8 fols., NGMPP reel-no. AT 85/10.

Tshe ring dbang rgyal, mDo mkhar zhabs drung (1697-1763)

dPal mi'i dbang po'i rtogs pa brjod pa ['jig rten kun tu dga' ba'i gtam], 861 pp., Chengdu: Si khron mi rigs dpe skrun khang, 1981.

Zhva sga pa dBang phyug bde ldan, rTsis dpon (1908-1989)

Gangs ljongs bod chos srid gnyis ldan gyi rgyal khab chen po'i srid don gyi rgyal rabs gsal bar ston pa zla ba 'bum 'phrag 'char ba'i rdzing bu'am / [blo gsar byung ba dga' ba'i rol mo], 2 vols., 685 & 640 pp., Kalimpong 1971.

lHa Tshe ring, mKhan po (b. 1960)

mKha' spyod 'bras mo ljongs kyi gtsug na sprul pa'i rnal 'byor mched bzhi brygud 'dzin dang bcas pa'i byung ba brjod pa [blo gsar gzhon nu'i dga' ston], 263 pp., Gangtok: Khenpo L. Tsering, 2002.

Western Literature

Aris, M. 1979. *Bhutan: The Early History of a Himalayan*. Warminster.

Cüppers, C. 2007. "Registers and Account Books of the dGa'-ldan pho-brang Government." In *The Pandita and the Siddha: Tibetan Studies in Honour of E. Gene Smith*. Dharmashala, pp., 12-15.

Diemberger, H.G.M. 1994. "Mountain Deities, Ancestral Bones and Sacred Weapons: Sacred Territory and Communal Identity in Eastern Nepal and Southern Tibet." In *Tibetan Studies*, 1 (= The Institute of Comparative Research in Human Culture, 1:1). Oslo, pp. 144-153.

_____ 1997. "Beyul Khembalung, the Hidden Valley of the Artemisia: On Himalayan Communities and their Sacred Landscape." In *Maṇḍala and Landscape* (= Emerging Perceptions in Buddhist Studies, 6). New Dehli, pp. 287-334.

Dudjom Rinpoche Jikdrel Yeshe Dorje 1991. *The Nyingma School of Tibetan Buddhism: Its Fundamentals and History*. Boston.

Ehrhard, F.-K. 2001. "Concepts of Religious Space in Southern Mustān: The Foundation of the Monastery sKu-tshab gter-lnga." In *Kāgbeni: Contributions to the Village's History and Geography* (= Giessener Geographische Schriften, 77). Giessen, pp., 235-246.

_____ 2003. "Political and Ritual Aspects of the Search for Himalayan Sacred Lands." In *The History of Tibet, Vol. II: The Medieval Period: c. 850-1895*.

- The Development of Buddhist Paramountcy*. London / New York, pp. 659-674.
- _____. 2007a. "A Forgotten Incarnation Lineage: The *Yol-mo-ba sPrul-skus* (16th to 18th centuries)." In *The Pandita and the Siddha: Tibetan Studies in Honour of E. Gene Smith*. Dharamshala, pp. 25-49.
- _____. 2007b. "The Biography of sMan-bsgom Chos-rje Kun-dga' dpal-ldan (1735-1804) as a Source for the Sino-Nepalese War." In *Pramāṇakīrtiḥ: Paper Dedicated to Ernst Steinkellner on the Occasion of his 70th Birthday, Part 1* (= Wiener Studien zur Tibetologie und Buddhismuskunde, 70.1). Vienna, pp. 115-133.
- _____. 2008. '*A Rosary of Rubies*': *The Chronicle of the Gur-rigs mDo-chen Tradition from South-Western Tibet* (= Collectanea Himalayica, 2). Munich.
- Hooker, J.D. 1987 [1854]. *Himalayan Journals or Notes of a Naturalist in Bengal, the Sikkim and Nepal Himalayas, the Khasa Mountains etc.* Delhi (Original: London).
- Mullard, S. 2005. "The 'Tibetan' formation of Sikkim: Religion, Politics and the Construction of a Coronation Myth." *Bulletin of Tibetology*, 41:2 (= Special Issue: Tibetan Lamas in Sikkim), pp. 31-48.
- _____. 2009. *Opening the Hidden land: State Formation and the Construction of Sikkimese History*. Unpublished D.Phil. (Ph.D.) thesis. University of Oxford.
- Petech, L. 1972. *China and Tibet in the Early XVIIIth Century; History of the Establishment of the Chinese Protectorate in Tibet* (= Monographies du T'oung Pao, 1). Leiden.
- Pradhan, K. 1991. *The Gorkha Conquests: The Process and Consequences of the Unification of Nepal, with Particular Reference to Eastern Nepal*. Delhi / Bombay / Madras.
- Robertson, D. 1998. *North of India: Some 19th Century Europeans in the Himalayan Regions and Central Asia*. Bangkok.
- Schrader, H. 1988. *Trading Patterns in the Nepal Himalayas*. Saarbrücken / Fort Lauderdale.
- Sørensen, P.K. & Hazod, G. 2007. *Rulers on the Celestial Plain: Ecclesiastic and Secular Hegemony in Medieval Tibet: A Study of Tshal Gung-thang* (= Österreichische Akademie der Wissenschaften, Phil.-Hist. Klasse Denkschriften 361 / Veröffentlichungen zur Sozialanthropologie, 10). Vienna.
- Steinmann, B. 1988. *Les Marches tibétaines du Nepal: État, chefferie et société traditionnels à travers le récit d'un notable népalis*. Paris.
- _____. 1998. "The Opening of sBas yul 'Bras mo'i ljongs according to the Chronicle of the Rulers of Sikkim: Pilgrimage as a Metaphorical Model of the Submission of Foreign Populations." In *Pilgrimage in Tibet*. Richmond, pp. 117-142.
- Tsepon, W.D. Shakabpa 1987. *Tibet: A Political History*. New York.
- Vandenhelsken, M. and Bhutia, H. W. 2006. "Tibetan Masters and the Formation of the Sacred Site of Tashiding." *Bulletin of Tibetology*, 42:1-2 (= Special Issue: Tibetan Contributions to Sikkim), pp. 65-92.
- Waddell, L.A. 1991 [1899]. *The Buddhism of Tibet or Lamaism*. Delhi (Original: London).
- White, J.C. 1999 [1909]. *Sikkim and Bhutan: Twenty-one Years on the North-East-Frontier 1887-1908*. Delhi.

NARRATIONS ABOUT A YOGĪ IN SIKKIM¹

MÉLANIE VANDENHELSEN
Namgyal Institute of Tibetology

Chathak Rinpoche (lCags thag Rin po che) was a Tibetan yogī who lived from the end of the nineteenth century until 1958. His name literally means ‘iron cord’ and was given after the iron chains he used to wear around his chest. He came to Sikkim at the beginning of the twentieth century, while living the life of a wandering yogī. He spent around fifty years in Sikkim mainly in the village of sGang rgyab, near Zil gnon in West Sikkim, with his Lepcha wife and his children.

The following information on Chathak Rinpoche comes from several members of his family. As most of Chathak Rinpoche’s children are deceased (except the youngest son and two daughters), more distant relatives have been interviewed. These informants’ relationships to Rinpoche are shown in a family tree (see Annexe 1) in which they appear in black.

The informants often gave different versions of the same event. Chathak Rinpoche’s life story indeed belongs to the rich tradition of oral history and as such is subject to variations. To preserve this specificity of non-written history, I will here consider the collected data as narrations. This article is thus more about the actual interpretations of Rinpoche’s deeds than a historical work. This stand relies on these methods:

1) Describing the conditions of knowledge: how did the informants obtain their information? The informants’ names are not given here because their reliability does not depend on who they are but on their relationship to Rinpoche.

¹ Thank you to the informants who provided the material for this article, namely, Pema Diki from sGang rgyab, Chota Ajo, Palchen Dorje Chatak, Namgyal Tshering Chatak, Lupon Tempa Gyatso, Namkha Gyaltzen, Yabchung Bhutia, Dawa Gyatso Bhutia, Phurpo Tshering Bhutia, Palphun Yongda and Tshering Wangchuk Barphungpa. Thank you to Tashi Densapa, Jenny Bentley, Kakoli Chaudhuri, Vikash Pradhan and Palchen Dorje Chatak for their corrections and comments—the possible mistakes remain mine—and to Yeshe Wangchuk, Namgyal Institute of Tibetology, who assisted me during this research and translated the interviews from *lho skad* into English.

2) Relating all different versions without attempting to identify any as the truthful representation of historical facts. This method has two advantages: to reveal the information, which appears most frequently and is therefore the one which can most probably be considered as factual; and to identify themes in the narration.

3) Considering that the narration is a construction based on real facts and themes of thought (coming from other narratives, scriptures, etc.) and attempting to identify the latter.

While the informants will be introduced in the first part, the second part will describe the different versions of Chathak Rinpoche's life highlighting themes which appear in the accounts.

- Informant 1 is the widow of Chathak Rinpoche's second son. She lives in sGang rgyab and was interviewed in Gangtok in the presence of her grandson (informant 7). She was born in the Earth Snake year of 1929 and is now 79. After marriage, she moved into Rinpoche's house when he was still alive. She was close to her mother-in-law (with whom she lived for twelve years, before and after Rinpoche's death) from whom she obtained her information about Chathak Rinpoche (as we will see below, Rinpoche did not talk much about himself). She is also close to Chathak Rinpoche's second daughter with whom she still shares stories about Rinpoche. She obtained additional information from her own mother who came from Zil gnon near sGang rgyab. Her grandson (informant 7) also answered my questions while working on this paper.

- Informant 2 is the brother-in-law of Chathak Rinpoche's youngest son. He lives in Zil gnon where he was interviewed and is about 75 years old. He regularly met with Chathak Rinpoche, notably in the days preceding Rinpoche's death.

- Informant 3 is the youngest son of Chathak Rinpoche's second son. More than an informant, he was our guide during our visit to his grandfather's village.

- Informant 4 is the nephew of informant 1 and is about 50 years old. He obtained his information from his father, to whom Chathak Rinpoche was the 'root spiritual master' (Tib. *rtsa ba'i bla ma*).² Informant 4's father was originally from Zil gnon. He was a close friend of Chathak Rinpoche's eldest son, known in Sikkim as sGang rgyab 'mTshams po Rinpoche, and died in the summer of 2006.

- Informants 5 and 6 are the sons of Chathak Rinpoche's youngest daughter, who, with her sister, married the same man from Ra lang.

² The mention 'Tib.' indicates words in Tibetan transliterated with the Wylie system.

The eldest son, informant 5, was interviewed several times in Gangtok where he resides. He obtained his primary knowledge on Chathak Rinpoche from his own father and, as he is himself carrying out research on Rinpoche, has also collected information from various sources. His brother, informant 6, was interviewed in Ra lang, where he resides with his mother and her sister. Due to poor health, both daughters could not be interviewed but the son, informant 6, narrated whatever information he had heard from them.

- Informant 8 has also devoted time to gathering information on Chathak Rinpoche. He was close to his mother-in-law and to informant 1's mother from whom he collected information. He was interviewed in Gangtok in the presence of his half-brothers-in-laws, informants 9 and 10. Informant 10 also answered my questions, mainly concerning his family, all along the preparation of this work.

VERSIONS OF CHATHAK RINPOCHE'S LIFE

His origin

Chathak Rinpoche was born in the Water Sheep year of 1883 (informant 4). Informant 8 gives the year of 1870 however, without knowing the Tibetan year. Rinpoche's name was Padma gling 'phro' (see Tibetan text in Annexe 2). Several informants mentioned that he was from a higher class (informant 6) or even the son of a royal family (informants 1 and 2); according to informant 5, he was the son of a provincial chieftain named Bya dral rGyal po. He had at least one brother who came to visit him in Mangthiang, which is the hamlet of sGang rgyab where he lived with his wife (informants 1 and 4).

According to most informants, Rinpoche was born in the north-eastern Tibetan province of mGo log (informant 1, 4 and 5).³ Before 1950, the region of mGo log was in south-eastern A mdo (see map below), bordering on northern Khams;⁴ it is located on the south-eastern slopes of the A myes ma chen range, which is now in the Chinese province of Qinghai. According to informant 1, g.Yang thang Rinpoche⁵ built a monastery in Chathak Rinpoche's place of origin in

³ He was born in a place named 'Dotrapu' according to informant 8, but no detail could be found about this place.

⁴ The southern part of mGo log was in Khams but the capital, Machu, was in A mdo.

⁵ The person most commonly known in Sikkim as g.Yang thang Rin po che is actually gTer ston rDo rje bde chen gling pa, also known as mDo mang Rinpoche and incarnation of mDo mang gTer ston. His religious lineage is originally from Khams. He is believed to be the incarnation of lHa btsun chen po.

Tibet. Informant 1 asked g. Yang thang Rinpoche’s niece to describe the place and was told that it is a high altitude mountainous area.

It is interesting to note that all of these informants locate mGo log in Khams and according to two others (2 and 6), Chathak Rinpoche said he was born in Khams Mi nyag, which is around 200 miles

Map of Tibet before 1914⁶

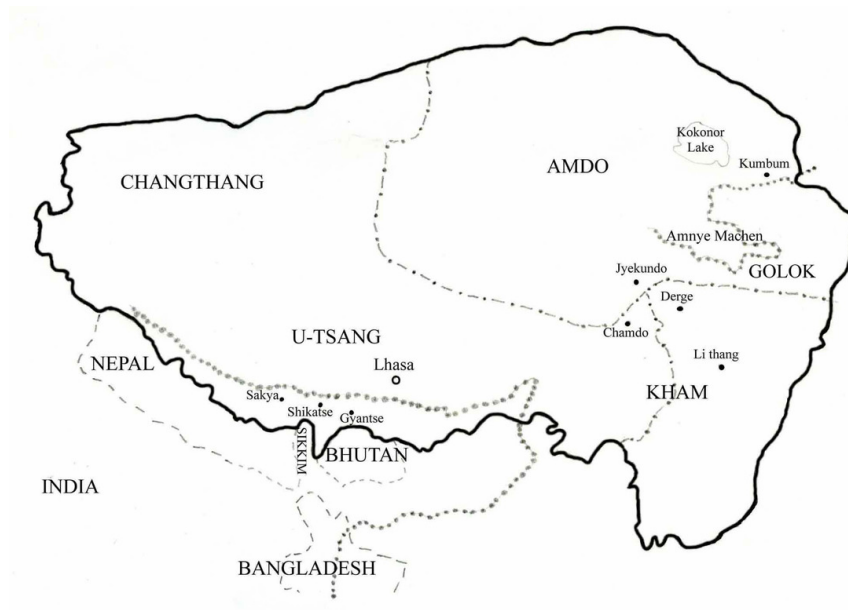

- Tibetan boundary
- Old provincial boundary
- International boundary
- Rivers

southward near Li thang.⁷ Khams Min yag was the place of origin of Gyad ’bum bsags, the ancestor of the Sikkimese Chogyals and of the major Lho po clans according to one of the versions of the origin of the

⁶ Based on <http://omni.cc.purdue.edu/~wtv/tibet/map.html>

⁷ See R.A. Stein, 1951.

Namgyal dynasty.⁸ To assign the origin of Chathak Rinpoche to Khams and particularly to Khams Mi nyag further contributed to his and his family's high social status. Rinpoche's origin together with his own prestige have succeeded in conferring a high status to his family; almost all of its members have married Lho po spouses. Moreover, several members of the family are addressed as 'yab,' which is a title of high social status in Sikkim.⁹

His lineage of incarnation

Chathak Rinpoche was the 16th incarnation (or 13th according to informant 7) of a lineage of *sgrub thob* or siddha, i.e. 'accomplished ones' (informant 6). All informants give the same names for his previous incarnations, but the order varies (again see the text in Annexe 2). The founder of the lineage was an Indian siddha called Saraha. The biography of Saraha found in the web site of the Dharma Fellowship of His Holiness the rGyal ba Karmapa¹⁰ reads as follows:

Acclaimed one of the greatest yogis of India in the late 8th century, the indomitable Saraha heads the Mahamudra lineage. He was born into a Brahmin class family in Bengal, eastern India.

The text then explains how Saraha, though raised to become a Buddhist monk (at that time, the Pala dynasty of Bengal was promoting Buddhism), was expelled from his monastery because he broke the rule; he then became a wandering yogī. Afterwards,

He became the disciple of a saint named Ratnamati, who was a master of the *Guhyasamaj Tantra*. Thus Saraha learnt the profound secrets of a method of meditation that focuses on raising *kundalini* [...] and abiding in blissful Mind's own innate state.

He eventually met a woman who became his wife and to support his family, he took up the craft of making arrows. The very name 'Saraha' is derived from his occupation as a maker of arrow. The text continues:

Saraha begins the lineage which descends through his disciple Savari to Luipada, to Dengri, Vajraghanta, Kambala, Jalandhara, Krsnacarya,

⁸ According to another version, Gyad 'bum bsags originated from the northern Mi nyag, also called Si-hia (or Xixia), located near to the Kokonor lake in Tibet. See mThu stobs rnam rgyal and Ye shes sgröl ma, 1908.

⁹ The etymology of the word is unclear. In Tibetan, 'yab' is the honorific term meaning 'father.' It could have become a title in Sikkim, making paternity a metaphor of superiority. But it could also be a contraction of 'yar pa' or 'above ones.' 'Yab' most frequently applies to the landlords (kazi) and to high lamas.

¹⁰ <http://www.dharmafellowship.org/biographies/historicalsaints/saraha.htm>

Vijayapada, to Tilopa and Naropa, the teachers of Marpa of Lhotrak. Marpa was the renowned teacher of Tibet's greatest yogi Milarepa, and the latter taught Gampopa, who in turn was the teacher of the first Karmapa. Today, the Karmapa is the living custodian of this Mahamudra meditation lineage.

According to the text given in Annexe 2, "In [his] second [life], Chathak Rinpoche incarnated in Maha guru bSod nams rin chen (also called Ma ni bSod nams rin chen) or sGrub chen Thang stong rgyal po." As this sentence suggests and as informant 5 believes, bSod nams rin chen could be another name for Thang stong rgyal po. However, Cyrus Stearns who recently published a book on Thang stong rgyal po (2007) has never heard of this name being used for him, nor does he know any special connection between Thang stong rgyal po and Saraha.¹¹ According to most informants, Ma ni bSod nams rin chen was the previous incarnation of Chathak Rinpoche.

Thang stong rgyal po was born in La stod (western Tibet) in the second half of the 14th century.¹² "He is of course famous for his engineering feat of constructing iron chain suspension bridges over gorges and rivers in the many regions he visited. He was also the first to open up the region of the barbaric kLo-pas in Kong-po. He constructed auspicious stūpas and temples at key geomantical spots to ward off both evil forces and real menace of the Hor-pa tribes. He is connected with the origin of the Tibetan drama tradition and the monastic orchestra."¹³ He also discovered many *gter ma* and initiated major lineages but there is no unanimity as to which school he belonged, being variously claimed as rNying ma pa, bKa' brgyud pa and Sa skya pa.¹⁴ According to Samuel,¹⁵ his links are more with the 'Shangpa Kagyupa' than with the rNying ma pa;

This small Kagyüdpā tradition, which claimed to go back to Ky'ungpo Neljor and the teaching of Niguma, Nāropa's sister or consort, rather than to Marpa and Nāropa, was one of the Kagyüdpā yogic traditions that continued to exist quietly alongside the large monastic *gompa* of Karmapa, Drugpa, and Drigungpa.

¹¹ Personal communication.

¹² There is no unanimity concerning his dates; he could have been born in 1385, 1361 or 1421 and died in 1464, 1459, 1485, 1510 or 1519 (see Stein, 1981: 53 and 267 n72, Samuel 1993: 518 and C. Stearns 2007).

¹³ Gyatso, 1979: 111.

¹⁴ *Ibid.*

¹⁵ 1993: 518.

According to informants 1 and 8, Chathak Rinpoche also incarnated as gLing Ge sar. Ge sar was the hero of the Tibetan epic, who became king of gLing, a country which existed from at least the end of the 14th century.¹⁶ He is the founding ancestor of the people of Khams, “a culture-hero who defeated the demonic or non-Buddhist kings of the four directions and ruled over all of east Tibet.”¹⁷ He was indeed a “tamer,” both of demons and hostile forces in general, and of men.¹⁸ Ge sar is also one of the “trickster-like figures” whose activities are frequently devious and treacherous according to the rules of ordinary morality, but always legitimated by a higher spiritual purpose.¹⁹

The link between Chathak Rinpoche’s previous incarnations is uncertain. A connection to the Karmapa and the bKa’ brgyud pa schools of Buddhism is established with Saraha and Thang stong rgyal po. But he cannot be located in one particular monastic lineage. The links with his previous incarnations are elsewhere: as we will see, several of these previous incarnations’ characteristics emerge from the narrations on Chathak Rinpoche, such as his distance from the monastic institution and his activities as a ‘tamer’ of demons.

Chathak Rinpoche’s relationships to the monastic institution

Chathak Rinpoche was a *sgrub thob* or ‘accomplished one’, which is defined in Sikkim as a religious specialist who does not have to follow the rules of life that apply to the members of the Buddhist religious community (Skt. *vinaya*, Tib. *'dul ba*). But, according to informant 4, who is a lama, Chathak Rinpoche studied in a rNying ma pa rDzogs chen monastery in mGo log where he practiced *rtsa rlung* or anu yoga, which leads to the control of the internal channels and vital energies. Though other members of his family agree that Rinpoche was an accomplished practitioner of *rtsa rlung*—which explains why he had to wear chains around his body (to prevent himself from flying) and how he could walk extraordinarily fast²⁰—they stress his distance from monastic practices.

Informant 1, for instance, explains that at a young age, Chathak Rinpoche was staying in a monastery, but once ran away with a white

¹⁶ See Stein, 1981: 243-245.

¹⁷ Samuel, 1993: 68-69.

¹⁸ *Ibid.*: 572.

¹⁹ *Ibid.*: 214. Concerning the Ge sar epic, see also Samuel, *ibid.*: 166, 540, 564 and 293-294.

²⁰ A common hearsay is that Chagthak Rinpoche was wearing chains to control his extraordinary power; he would have fallen into trance or become demonic if not.

goat. He was eventually caught and brought back. According to informant 6, it was from his house that Rinpoche ran away with a white goat when he was a child. An informant from Phodong, not related to Chathak Rinpoche, asserted that her grandmother once met Rinpoche meditating on a rock and asked him to come pray for a funeral. Rinpoche replied that he could not enter any house, but he would pray from outside for the deceased.²¹

Informant 1 adds that Rinpoche neither received nor bestowed any empowerments (Tib. *dbang*) or transmissions (Tib. *lung*). He also did not wear any monastic garments, but only covered himself with a leopard skin around the waist. “He was bound under oath to the gods and demons,” she explains. These accounts aim at showing that Chathak Rinpoche was a natural *sgrub thob*. As such, he had the urge to leave the monastery as well as his family to live the life of a wanderer. Monastery and family are here seen as stable and comfortable institutions which would have hindered the wandering life necessary to tame demons.

Another feature that demonstrates his difference from lamas is his discretion because “His intention was to liberate beings, not to teach them; he had the power to liberate corpses and living beings’ consciousnesses” explains informant 6. He was generally very discrete, not talking about himself and his powers. According to informant 7, this was not only a feature of his character but also a promise Rinpoche had made. The latter indeed was often repeated: “I’m not supposed to reveal what I am doing.” Informant 6 adds that Rinpoche’s discretion has become a feature of his descendants. Indeed, “It is said that they are all bodhisattvas. They never show off, never talk. They want to be left alone and contemplate in compassion. They have nothing to do with monasteries.”

Rinpoche used to read only one Tibetan religious text, the *rDo rje gcod pa* or ‘Diamond sutra,’ using a small hand ritual drum (*da ma ru*) and a ritual bell, but he did not perform rituals for donors (Tib. *mchod gnas*, i.e. ‘preceptor-donor’ relationship). Though the narrations concerning him display some of the ‘crazy siddha’s’ unusual behaviour—his half nakedness and his appearance, and probably his marriage with a Lepcha villager, which might have been uncommon for Tibetans a hundred years ago—they also show his respect for monasteries. Indeed, Chathak Rinpoche built a *tsa khang* or ‘house for clay icons of a deity’ (Tib. *tsa tsa*) in bKra shis sdings (Tashiding) and

²¹ In Sikkim, other lamas, even more involved into the monastic institution, never attend funerals.

once said to informant 4's father that Padma g.yang rtse (Pemayangtse) was a particularly holy place. But there is no ambiguity in these relationships to monastic institutions. Indeed, his distance from monastic institutions does not prevent a deep faith and the recognition of monasteries as centres of Buddhist practice and development. Monastic life was simply not the one he had to follow.

Rinpoche's life in Tibet

Though most informants agree that Chathak Rinpoche hardly talked about his life in Tibet prior to his first visit to Sikkim, informant 5 has information on this period of Chathak Rinpoche's life. He said that Rinpoche used to perform rituals and meditate in cremation grounds and was able to see the divine owners of the cemeteries (Tib. *dur khrod bdag po*). In Tibet, Rinpoche competed with a famous monk of the area who, after hearing about his powers, wanted to challenge him. Both men then decided to spend a night in the cold water of a nearby lake to see which of them would be able to remain the longest. On a specific date, they entered the water witnessed by an esteemed crowd. After a few hours the monk collapsed. He had to be dragged out of the water and resuscitated with the heat of blankets and tea. But Chathak Rinpoche stayed in the water until morning. The next day, the monk came to meet him, apologized and recognized Rinpoche's religious superiority. This story suggests that Rinpoche was a '*ras pa*,' i.e. one who controls his inner fire and can raise his inner heat, a technique of which Mi la ras pa was a famous adept. Still according to informant 5, Chathak Rinpoche recognised his first son as an incarnation of one of Mi la ras pa's disciples.²² These narrations probably aim at ascertaining Chathak Rinpoche's connection to sGrub thob Saraha.

Beginnings in Sikkim

Chathak Rinpoche's arrival in Sikkim follows his successful escape from his home and the monastery (informant 1). The precise date of his arrival in Sikkim is unknown. It was around the year 1900 according to informants 5 and 8 (for whom, Rinpoche was then 30 years old, believing he was born in 1870). Rinpoche was also 30 years old according to informant 4, but 18 to 20 years old according to informant 7, and 25 according to informant 6. This latter informant adds that Rinpoche told his wife he was 25 years old when he met her for the

²² It would be of Mi la ras pa's master, i.e. Mar pa, according to informant 7.

first time. In any case, Rinpoche arrived before 1910 (Iron Dog year) since his first son was born that year in Tibet, where he returned with his wife after having met her in Sikkim. According to informant 1, a war between the British and the Tibetans was being waged when Rinpoche arrived in Sikkim; it was most probably the 1903-04 war, which broke out due to the Younghusband mission to Lhasa. Assuming that Chathak Rinpoche was born in 1883, he was 20 or 21 years old when he arrived in Sikkim in 1903 or 1904.

The order of the places he visited in Sikkim also varies depending on the informants. For most of them (informants 1, 2, 4, 6 and 8), Rinpoche first went to Phodong after arriving from Chumbi via Lachung. At that time, his feet would not touch the ground—he was in a state of permanent levitation—because of his achievements in yogic practices. Therefore, he built a *mchod rten* (stūpa), filled it with precious objects and, tied a rope at each corner which he planted in the soil. He was then able to walk on the ground (informants 1 and 4). Nevertheless, he continued to wear chains around his body.

His uncommon appearance is described in a story which would have occurred in the Phodong area (informants 5 and 6). Informant 5 describes the incident as follows:

On his way to the consecration of one *mchod rten*, Chathak Rinpoche met two hunters. One of them was the Raj Kumar and the other was Rhenock Athing.²³ Rinpoche came out of a bush so suddenly that the two hunters got scared and did not think that this being, who wearing only a leopard skin around his waist and chains on his chest, was human. They pointed their guns toward Rinpoche and asked, ‘Are you a ghost?’ Rinpoche answered he was a human and the prince understood he had miraculous powers.

The wandering demons’ tamer

Chathak Rinpoche then spent some time wandering from place to place. The names of these places—which vary depending on informants—can be considered as tangible testimony of Rinpoche’s power to subdue and liberate demons. Doing so, Chathak Rinpoche proved ’Bras ljongs’s (Sikkim’s) sanctity and added his own blessing to it.

²³ The prince mentioned here was most probably Prince Paljor (1921-1941) who was Chogyal Tashi Namgyal’s eldest son. Rhenock Athing (Sonam Dadul) was the chief steward of the palace and was a famous hunter. Later on, in the 1950s, his eldest son (Tse Ten Tashi) took the only photo of lCags thag Rin po che. Thank you to Tshering Wangchuk Barphungpa for this information.

Rinpoche went to Sing gtam (Singtam), to a place called Shing chu thang, to Theg mchog yang rtse (Thekcho Yantse) above gSang sngags chos gling (Sangacholing), to bDe chen phug where he meditated, to rGyal ba (Gyewa) near rGyal shing, to Grub sde (Dubdi), to mKha' spyod dpal ri (Kechuperi), to gSang gnas me 'bar phug (Sangne Mebar phug) via rDo rje 'Pham, to Zil snyan (Sinek) and bKra shis sding (informant 4). He stayed in the Sa skyong area near rGyal shing for almost a year (informant 6); he went to Nam rtse (Namchi) and stayed in Yang rtse, below Rab gdan rtse (Rabdentse), for many years (informant 8).

Wherever he went, he used to put up several tents even though he was alone (informant 4). In Phodong (informant 2) as well as in Zil gnon (informant 1), he put up seven tents, each of a different colour. In each he kept a shrine (Tib. *dkyil 'khor*) for offerings to the deities. Informant 1's mother saw the tents in Zil gnon and noticed that Rinpoche was not sleeping in any of them at night nor was he seen in them during the day. The informants here suggest that he was playing host to a retinue of deities, invisible to normal beings, while he himself was engaged in secret activities.

His activity was most likely the taming of demons and liberating beings as he did in the Singtam area (informant 4). Here, he saw a tree entirely wrapped by climbing parasite plants. He cut the climbing plants and offered it to the deities to remove their negative deeds, threw it in different directions, and then shot an arrow in each direction. In doing so, he liberated the tree. Informant 4 also tells that one day, his father and Chathak Rinpoche's second son caught some frogs. They hung the animals from the window of a house. When Rinpoche saw them, he said, "these animals suffer the consequences of their bad deeds", and started to pray facing Gangs chen mdzod lnga. In the evening, Chathak Rinpoche released the frogs into the river Rinjan Kyiong. Early the next morning, he prayed again and in the evening of the same day, a heavy rain fell and all the frogs disappeared from the river. "We can say that the frogs have been swept away by the flood or that they have gone to heaven. Even now, frogs are rarely seen in this river," comments informant 4.

Chathak Rinpoche devoted an important part of his life to building *mchod rten* with different intentions. In Tibet (informant 6), he built one for protection against war (Tib. *dmag zlog*). But most of the time, the *mchod rten* were intended to 'exorcise' or 'tame' the local deities (Tib. *bzlog thabs*) as was the case of the *mchod rten* built at Tenth Mile

in Kalimpong²⁴ on a land donated by a Bhutanese queen. Eight of them were built in Mangthiang (probably ‘Moong phyang’ in Lepcha) where he resided with his wife and children (informant 5). The latter can still be seen today in the forest near to Chathak Rinpoche’s old house around forty-five minutes walk below sGang rgyab. Near one of them is a ‘house for the serpent spirits’ (Tib. *klu bum*), also made by Rinpoche. Rinpoche built Mangthiang *mchod rten* at night and refused any help. Because the construction was very fast nevertheless, it is believed that he received supernatural support (informant 5).

Rinpoche also built the *mchod rten* in the market place in rGyal shing and the ‘*ma ni* wall’ going from the *mchod rten* to the Ma ni lha khang down the road bordering the taxi stand. According to informant 4, he made these buildings to remove obstacles for Sikkim that will originate in rGyal shing. Informant 4 comments that the events of 1973 indeed started from this place. This comment aims to demonstrate Chathak Rinpoche’s visionary power that I will mention again below.

According to informant 5, Chathak Rinpoche used to leave rings of his chains—made of different precious metals—in the *mchod rten* he was building in order to bless the place and transmit to it the force of protection given to the object by contact with his body.

Another realisation of Rinpoche can be seen in Zil gnon. Near the monastery are three raised stones facing each other and representing ‘thrones’ (Tib. *khri*). On one of these thrones, Chathak Rinpoche carved the outlines of Ma ni bSod nams rin chen with crossed legs, holding a prayer wheel (*ma ni*) in his right hand, what appears to be a bone trumpet (Tib. *rkang gling*) in the left, and a strap on his chest. The second one is a long rectangular stone on which ‘Om a’ hum’ is carved and the third one is apparently not carved but, according to informant 2, bears the natural carving of Kun tu bzang po. Other informants agree saying that it is no longer possible to know what the last two stones exactly represent. Informants 2 and 6 explain that Rinpoche’s intention whilst making these thrones was to create auspiciousness for the future (Tib. *rten ’brel*). Informant 1 said that when the time came to consecrate the thrones, Chathak Rinpoche searched for two girls to sit on them, representing or being *dākinī* (Tib. *mkha’ ’gro*). He found one of them, but the second, who was informant 1’s mother, could not come. This anecdote explains why the meaning of Rinpoche’s realisation was not transmitted to his family. Rinpoche consecrated the thrones with only one girl.

²⁴ This *mchod rten* was destroyed but there are photos of it.

Chathak Rinpoche's thrones in Zil gnon have recently been restored and a shed to cover them is under construction. A concrete support has been built to hold up the stones and interestingly, Ma ni bSod nams rin chen's outlines have been replaced by a more figurative painting. The character's features now clearly appear, seated crossed legged with a mountain in the background. He bears a leopard skin around his waist, still holds a *ma ni* in his right hand and a bone trumpet in the left. The strap on his chest now holds a quiver, adding to his character as a demon's tamer.

Another of Rinpoche's accomplishments in terms of taming evil spirits are the raised stones of Srin 'dzom (Sinzom) or Srin mo 'dzom ('gathering place of the ogresses') on the way to Zil gnon. The story of this place was recounted in the newspaper by Dawa Gyatso Mawepa:²⁵

Four to five decades ago, at the place called Simuzum, there used to assemble witches from dusk to dawn and harmed the people and animals alike. One evening, a nun who was meditating at Risoong Cham-Khang, a secluded forest area, went to collect firewood adjacent to the place called 'Simuzum' meaning 'gathering place of the witches or rendezvous of the witches.' There she saw three witches assembled on a flat rock and preparing to cook something on the hearth. The nun hid herself in the bushes and threw a stone, which directly hit the pot on the hearth and overturned it. The frightened witches ran away some distance from the flat rock and one of the witches loudly enquired about the other in a strange language, '*Kur-to-Ma-Gnyek-Ka?*' The other replied, '*Kur-To-Gnyek-Pe-Jaam-Syo-Tong-Tong.*' The meaning and language of the words spoken by the witches are not understood till date.

Later at the arrival of His Holiness the Chyak-Thak Rimpoche at Gangyap, he understood the presence of evil spirits at Simuzum and was determined to pacify the evil spirits with his own method. Around the year 1915, one early morning before daybreak, His Holiness miraculously carried the big bulk of stones to the flat rock of Simuzum. When the last bulky stone was about to be piled up with the other stones on the flat rock where the witches used to assemble—this was at the break of dawn—a teenage Lepcha girl happened to pass through that place [the girl was called Mache Nyukon from Chongran, and passed by carrying a bamboo container, according to informant 8] and saw His Holiness with the big stone. Knowing that he was being watched, His Holiness instantly threw the stone at the bottom of the *katusl shokey* tree. Later on, His Holiness consecrated the pile of stones at Simuzum along with the three big *katusl shokey* trees around

²⁵ *Now!* 2005.

the flat rock. Two of the trees stand in the spot even to this day. From that time onwards, the evil spirits of Simuzum have ceased to trouble the people and it is believed that His Holiness Chyak-Thak Rinpoche subjugated the evil spirits not only of Simuzum but also of Mangthyang.

Informants 1 and 2 tell a slightly different version of the same story: While the abbot or rDo rje slob dpon of Zil gnon monastery was in meditation, his wife brought him food every day. One day, she saw seven ogresses (Tib. *srin mo*) cooking human bodies in a pot (according to informant 1, it was human babies' bodies). She threw a stone on the pot which broke. Three of the witches then talked to four others. Informant 2 quotes precisely the same dialog in an unknown language as Dawa Gyatso Mawepa, but translates it as "are you all right?" "We are fine but the pot is broken." Chathak Rinpoche came later and subdued the demons. Informant 2 concludes, "Before, this place was very dangerous and who ever was going there could die. Now, it is a holy place."

Chathak Rinpoche's achievement in blessing the land of Sikkim was elucidated by a recent event. In the village of Ran thang, three kilometres away from Phodong, a local family has undertaken the restoration of a 'temple for fasting' (Tib. *bsnyen gnas lha khang*) located next to a flat rock on which Rinpoche meditated. A *mchod rten* was built near the rock. In this village there is also a holy water spring that people link to Guru Rinpoche. This area therefore links Chathak Rinpoche and Guru Rinpoche. This link will be commented on in the conclusion.

At bKra shis sding (informant 4) or Yang rtse (informant 8), in a cave where he was meditating, Chathak Rinpoche found a stone on which Mi la ras pa's shape was naturally carved. He found this stone after trying to locate the source of the echo of the mantra he was reciting. Rinpoche then also became a 'treasure discoverer' (Tib. *gter ston*).

In search of his 'secret consort' (Tib. gsang yum)

According to informant 8, Chathak Rinpoche came to Sikkim motivated by the search for his consort. The details about his gSang yum's (Chathak Rinpoche's future wife) parents have been nowadays forgotten by their neighbours in Mangthiang. According to informant 1, her parents were farmers from Mangthiang and had fields in a place called Nambung Tarang, near sGang rgyab, and near the river, in a place called Dhim rop kyong. The father of Chathak Rinpoche's future

wife gave this latter land to her. One of her uncles was a forest guard for the Chogyal.

The story of Chathak Rinpoche's meeting with his future wife goes as such: According to informant 1, Chathak Rinpoche shot an arrow from rGyal shing to gSang ngags chos gling monastery where the niece of Kha' spyod gru dbang Rinpoche (also called Kha' spyod sKu zhog [informant 1] or Kun bzang bla ma [informant 8]) was meditating. Informant 8 says that the girl was meditating under her uncle's guidance²⁶ and was 18 years old. The arrow reached gSang ngags chos gling also according to informant 8, but it was in Kha' spyod dpal ri according to informant 2. Informant 8 describes Chathak Rinpoche's future wife as an assiduous Buddhist practitioner who meditated for twelve years.

Informant 1 continues the story saying "Shooting the arrow was like casting the dice and it is Kha' spyod gru dbang Rinpoche's niece who found the arrow. Some say that the arrow hit the mortar, whereas others say it hit the door of her meditation house." In informant 2's version, what informant 1 means by "casting the dice" appears to mean destiny determined by a previous life, which in Tibetan thought is called 'prophecy'. Chathak Rinpoche's arrow hit a bush where Kha' spyod Rinpoche's niece found it. The girl brought it to her uncle who explained, "It is a good sign that you will soon find a good person." Kha' spyod Rinpoche then put the arrow on the altar. In the evening, Chathak Rinpoche came looking for his arrow. Kha' spyod Rinpoche gave his niece to him saying, "It is according to the prophecy."

Informant 1 and 8 make clear that Kha' spyod Rinpoche's niece had carefully kept the arrow (she even wrapped it in a ceremonial scarf according to informant 1) and handed it over to Chathak Rinpoche when he came looking for it.

Further information, told later by the informants while mentioning Chathak Rinpoche's wedding, casts some light on the previous story. The girl was already promised to another man but she had refused this engagement. It was at that time that her uncle, Kha' spyod gru dbang Rinpoche, who was supporting her, told her that she had a good destiny and would meet a great husband. For this reason she went to meditate, waiting for her husband to come (informant 1). According to informant 6, gSang yum's elder sister got married to a man from bKra shis sding, but refused to go live in her in-law's house and died suddenly.

²⁶ Kha' spyod gru dbang Rin po che was the maternal uncle of lCags thag Rin po che's future wife.

Therefore, gSang yum was asked by her parents to go replace her elder sister, but as she was still a child, she refused.

Kha' spyod gru dbang Rinpoche is also an interesting character who links Chathak Rinpoche to a Sikkimese lineage of reincarnations. His story is told by informant 8 (it is also told, though with less details, by informant 1):

Kha' spyod gru dbang Rinpoche was a very poor Lepcha. He was a manual labourer, working for free to build the g.Yang thang palace, near Padma g.yang rtse. At that time, the Lepcha were neglected. He had to excavate earth and while doing it, he fell into deep trance. He used to say in Lepcha, "I did not come onto earth for this kind of work." Therefore, somebody told g.Yan thang Kazi (landlord) that he was useless for this work. He was 15 years old at that time. One day, he was going to Kha' spyod dpal ri and met gCong phung Mandal (Tsekhyim Ajo) on the way. gCong phung Mandal was angry because he could not find stones to build his house. At that time, when a house was being built, the owner had to provide the stones. Kha' spyod Rinpoche asked him what he was doing and, as the Mandal was in a bad mood, he told him to mind his own business. But Kha' spyod Rinpoche advised him to excavate in three places and left. Later, gCong phung Mandal found stones at the places mentioned by Rinpoche and was amazed.

Kha' spyod Rinpoche constructed the *mchod rten* which stands besides Kha' spyod dpal ri monastery, after the model of one from Kathmandu [the *mchod rten* Bya rung kha shor built by Ma bya gzig ma, a previous incarnation of Kha' spyod gru dbang Rinpoche according to informant 5]. He did not use any iron tools. His sponsor was Phenchung Mandal's father. When Rinpoche told him he was going to construct the *mchod rten*, the donor offered his help but Rinpoche refused. He constructed the *mchod rten* at night. When it was about to be completed, the donor came early one morning to meet Rinpoche and saw him carrying stones in the air and talking while nobody was there.

Rinpoche was the incarnation of Ma bya gzig ma (a name which literally means 'caretaker of the hens and cocks'). Later on, he went to bKra shis sding and constructed a *mchod rten*—the one which has the 'vase' part up side down—behind the *mchod rten* mThong ba rang grol. When it was near completion, his mother expired and he left the construction unfinished. Later on bKra shis sding lamas completed it. He also constructed the *ma ni* wall below the school ground in Zil snyan Bazaar. When it was completed, a golden cock and a golden hen were seen flying. People thanked Rinpoche by offering him barley beer, but it was poisonous. This happened before Chathak Rinpoche's marriage. Chathak Rinpoche's future wife provided care to Kha' spyod

Rinpoche while he was dying. Once, when she was crying, he consoled her saying that everything is impermanent and that he will come back to take her first milk. He said that in the presence of the public and died one week later. Kha' spyod gru dbang Rinpoche reincarnated as Chathak Rinpoche's first son.²⁷

What Chathak Rinpoche and Kha' spyod Rinpoche's niece did after their first meeting is unclear. A story concerning Chathak Rinpoche's future wife, which happened before their first meeting, is told in addition to the story of the arrow shot in gSang ngags chos gling to show that Chathak Rinpoche and her were destined to meet. Informant 1 indeed explains: One morning, while Chathak Rinpoche's future wife was in sGang rgyab combing her hair, five objects that looked like butterflies fell on her (it was some kind of marbles or crystals according to informant 8; some golden pearls according to informant 4). She took it to mKha' spyod dpal ri to show it to her uncle (because her parents had advised her to go meet her spiritual guide to ask for the meaning of these objects, according to informant 8). The latter put the objects under a ritual bell and told her niece, "Don't become a daughter-in-law [i.e. do not get married right now], you have a good destiny [i.e. you will meet a high ranked husband] and you should practice the dharma [waiting for this husband]." According to informant 8, the uncle rather said, "Go to meditate in lHa ri snying phuk. You will meet your husband and you will have five sons bright as crystal." According to informant 4, the uncle concluded from the event that his niece was a *ḍākinī*.

Therefore, says informant 1, she did a retreat (Tib. *mtshams*) in the meditation house of the cremation ground in Zil gnon. Later, she meditated for one year in gSang ngags chos gling and during this time Chathak Rinpoche sent the arrow.

According to informant 8, the niece followed her uncle's advice and went to lHa ri snying phuk. But after a week of meditating alone, she heard drums and a trumpet. It scared her and she decided to leave. On her way back, she met Chathak Rinpoche at a place called rKang gling ga. They smiled at each other and went their own way.

Informant 1 adds, "We do not know what happened to the five objects; A nyo lags (Chathak Rinpoche's consort) asked her uncle for them but he did not give them back, maybe they were lost." The objects have disappeared by themselves according to informant 8. Informant 4 tells that, after the golden pearls had fallen on her dress, the girl showed

²⁷ This lineage is different from the one of the mKha' spyod sprul sku, whose previous incarnation was the *rdo rje slob dpon* of Padma g.yang rtse.

them to her father, but when the latter touched them, the objects turned black. But in mKha' spyod dpal ri, the uncle practiced a purification ritual (Tib. *khros gsol*) and the pearls became golden again.

Informant 1 and 2 explain that Chathak Rinpoche then went to sGang rgyab where the girl was living and made offerings to her parents, asking for her hand. He offered a plate (Lk.²⁸ *khang sa les sder*), a vase (Tib. *bum pa*) and some money from Tibet (Tib. *zho gang* or 'one unit of currency'). The parents agreed to give their daughter and the couple left for Tibet the next day (informant 1). But when the couple was leaving, the girl's uncles and villagers, disagreeing with her departure because she had been promised to another man, followed them asking "Why do you take our daughter-in-law?" (Informant 1)

But according to informant 8, the couple eloped to Tibet, without asking the girl's parents. We can assume that the girl's previous engagement, as well as their being followed by villagers, led to this conception. This view is shared by informant 6 who explains that when gSang yum's father learnt that a 'yogī type lama' from Tibet wanted to take his daughter, he opposed it and sent people after the couple to catch her and bring her back. Both informants then tell stories about the couple's escape. Informant 8's narration highlights Chathak Rinpoche's extraordinary powers:

When the villagers learnt that A nyo lags (gSang yum) had left with Chathak Rinpoche, they started to follow them until the Rangit River towards Ralang. When A nyo lags learnt she was being followed, she became nervous. On the Rangit river's bank, Chathak Rinpoche told her to sit on a stone; he then drew a line around the stone with an arrow and sat on another stone. When the people arrived, they demanded him to show the girl. Chathak Rinpoche told them to search by themselves and take her. But nobody could see her. She was very near and scared. Chathak Rinpoche told her not to panic. Later when the villagers left, he erased the line. The couple then left for Khams, which they reached after three months.

Informant 8's story of the escape displays the people's suspicions raised by Chathak Rinpoche's foreign origin and uncommon appearance, the strong commitment between Rinpoche and his wife as well as gSang yum's great powers and courage (the story is summarised here). He tells that when Chathak Rinpoche learnt that gSang yum's father was looking for her, he asked his assistant to hide her. This assistant was a man from Bhutan, according to informant 1,

²⁸ The mention 'Lk.' indicates words in *lho skad* i.e. the dialect of Tibetan spoken in Sikkim.

called 'Brug pa sgom chen.²⁹ He was living in Zil gnon and accompanying Chathak Rinpoche whenever the latter was travelling.

The assistant was hiding gSang yum from place to place while Chathak Rinpoche was moving on his side. Once, Chathak Rinpoche sent a letter to gSang yum's father, asking for her hand. But the father refused and angrily said, "I don't want to give my daughter to a stranger; we don't know him." But gSang yum's two brothers were supporting her and helped her to hide. Informant 8 then describes a route of escape going mainly through holy places, such as mKha' spyod dpal ri, Kongri, lHa ri snying phuk, Ra lang hot springs and gSer skyems thang, where gSang yum and Chathak Rinpoche met up. The couple then headed for North Sikkim in order to reach Tibet. But in La chung, two lamas sent by the father had come before to ask the villagers to stop the girl when they see her. When they were returning from La chung, the lamas met Chathak Rinpoche's group. They took the girl with them to bring her back home. But on the way, while they were reaching a bridge at twilight, gSang yum pretended she needed to pass water. She went behind a bush and disappeared. The lamas searched for her but, though she was wearing a red cap, could not find her. They thought she had gone ahead and left. But she had gone back towards La chung, using the same way. Soon, she met Chathak Rinpoche who was coming in her direction. In La chung, villagers tried to stop them but 'Brug pa sgom chen hit them one after the other and so the group could go to Tibet.

The yogī householder

In Tibet, Chathak Rinpoche and his wife visited several holy places (informants 1 and 6), including lHa sa where they went to the Jo khang temple (informants 4 and 6). They stayed in Tibet for two years (informant 6) or four years (informant 8). According to informant 6, the couple was travelling from place to place by horse with a retinue of servants. Moreover, Chathak Rinpoche had a lot of sponsors, some high-ranking, in Tibet. People used to gather around and rub barley flour on his body in order to bless the food. Therefore, Chathak Rinpoche avoided crowds and, when in a sponsor's house, he stayed in a separate room and only sometimes gave audiences.

²⁹ His son, called Samten Donyo, is nowadays living in bKra shis sdng. According to informant 6, 'Brug pa sgom chen and lCags thag Rin po che met in Tibet where the former was a pilgrim.

Chathak Rinpoche and his consort had their first son in Tibet during the Iron Dog year of 1910 (informant 5). This son was the incarnation (Tib. *yang srid*) of Kha' spyod gru dbang Rinpoche. According to informant 8, in Tibet, several *Rinpoche* recognized that the boy was incarnated and asked his father to leave him in Tibet. But Chathak Rinpoche replied that his son should live in Sikkim.

Chathak Rinpoche's second son was born in Sikkim in 1911 (informants 5 and 8). According to informant 6, Rinpoche and his family did not come back directly to Sikkim but, between 1910 and 1911, went to Kalimpong and Darjeeling. In Kalimpong, Chathak Rinpoche built the *mchod rten* at Ten Miles that I have mentioned earlier and informant 5 has a photo of a cave in which Rinpoche meditated. In the same town, Chathak Rinpoche performed miracles that the police understood as mischief's. Therefore, they put him in jail, but Rinpoche escaped after a very short time. The police put him back in jail but he escaped again. So finally, he was left in peace (informant 6).

Rinpoche did not like Kalimpong and soon left for Darjeeling. He did not like Darjeeling either so the family went back to sGang rgyab. gSang yum's father could not oppose their coming back and so let them stay (same informant).

Chathak Rinpoche and his family eventually settled in Mangthiang. From then until his death (i.e. during 47 years), he stayed in several houses in the sGang rgyab area, in an order which is uncertain. He and his consort stayed in Kongri (above sGang rgyab) for several years, in a place that the Lepchas call 'sKu zhog Partam.' 'sKu zhog' is a common Tibetan term of address for monks and high ranked persons; 'Partam' means 'flat land' in Lepcha language. Until that time, Chathak Rinpoche was indeed called 'sKu zhog' and not 'Rinpoche' (informants 1, 2 and 4). "People did not know yet that he was a *Rinpoche*," comments informant 4.³⁰

This was probably before he settled in Mangthiang (informant 7). In Mangthiang, Chathak Rinpoche and his family stayed in a house acquired from one of gSang yum's uncles (same informant). This house can still be seen today. It is a typical Lepcha house supported by big thick wooden pillars and with one corner of the roof rounded down.

Eventually, the family got a new house in Palegang, which is in the northeastern part of sGang rgyab, near to Chathak Rinpoche's reliquary

³⁰ However, Tashi Densapa, who met lCags thag Rin po che twice in his youth (at the end of the 1940s and at the beginning of the 1950s), recalls that lCags thag Rin po che was then called 'Rin po che.'

(Tib. *sku gdung*), which was built later. This house might have been bought from Lepcha (informant 1) unless, as it was common at that time, Chathak Rinpoche just settled on land which was unoccupied and later, when the first survey was done, was registered in his family's name (informant 7). The house in Mangthiang was left for Chathak Rinpoche's sons (informant 1).

During this time period, Chathak Rinpoche meditated in several 'houses of meditation' (Tib. *mtshams khang*), like, for example, in bSam gtan chos gling on the hill above sGang rgyab (informant 7) and in Ri gsung above Zil gnon (informant 5). Informant 2 tells that Rinpoche also meditated in Dotsu, near Lasso. A lama once used to meditate in this place, but was killed by a hunter who wanted to rob him. The lama reincarnated as a demon, haunting the place and harming people. Chathak Rinpoche went to meditate there in the evening, naked. This was witnessed by informant 10's maternal grandmother. Chathak Rinpoche subdued the demon and the place became peaceful again.

Several stories display Rinpoche's visionary power. One of them tells that one morning, in sGang rgyab, Rinpoche's wife found him lightening butter lamps with a very sad look. gSang yum asked what had happened and Chathak Rinpoche answered that his mother had died that morning in Khams (informant 4). "After that," adds informant 4, "people knew that he was not an ordinary man." Another story concerns informant 4's father who was also informant 1's brother. This man, who I will call rDo rje, was a layman (Tib. *'jig rten bo*) and took Chathak Rinpoche as his 'root master.' Chathak Rinpoche advised rDo rje to follow the dharma path. Therefore, rDo rje went to bKra shis sding to recite *rDo rje gcod pa* 1100 times in the Gu ru lha khang. One day, rDo rje went to collect wood. It was a sunny day and he was feeling very hot when he saw some water coming out from two sides of a big rock. He was very thankful and bowed down in front of the rock before he drunk the water. Then he returned to the Gu ru lha khang, took one silver and one copper pot and went back to the rock to collect water. He left the pots there to fill up and went again to the Gu ru lha khang to get a clay pot. When he arrived at the rock, the copper pot was full and the silver one was empty. He poured the water of the copper pot in the clay pot, reversed the places of the copper and silver pots, and left. When he came back to the rock once again, the copper pot was full of water and the silver pot was empty. The following day, Chathak Rinpoche's eldest son arrived, bringing food sent by Rinpoche. He also brought a message from Rinpoche saying that he should send him some

'nectar' or 'holy water' (Tib. *khros*). Indeed, Chathak Rinpoche had foreseen rDo rje's discovery and knew that it was holy water. But rDo rje did not send any water, perhaps because he doubted his own ability, and after Chathak Rinpoche had died, he regretted it. After few years, he went to bKra shis sding and searched for the rock, but it had been blasted to build a road (informants 1 and 4).

In addition to this visionary power, Chathak Rinpoche could see through people's behaviour and motivations, as stories told by one of Captain Yongda's son show. One of these narrations tells that, once, while a porter was bringing goods from a donor to Rinpoche, he made fun of the family he was working for. When he arrived in Mangthiang, Chathak Rinpoche repeated to him what he had said on the way. Another time, a porter carrying oranges to Rinpoche told his companion that it would be nice to eat one to appease his thirst. When he reached Rinpoche's house, the latter asked him if his thirst was appeased now. Another visitor hid his tobacco under a stone on his way to Mangthiang, fearing that Rinpoche might discover it. The person had his interview with the holy man and, before leaving, Rinpoche told him not to forget his tobacco on his way back. Tashi Densapa recalls similar events: his aunts, who were nuns, went often walking from Gangtok to Mangthiang to meet Chathak Rinpoche. Each time, they feared that the holy man would not be home because it was common knowledge that he could forecast the arrival of visitors; when he knew their intention was just curiosity to see an atypical being, he would leave the house.

Chathak Rinpoche continued to travel within Sikkim throughout his married life. He often went away after staying home for two or three months. He would not say where he was going. Before each departure, he took a bath, tied his hair, put on his yogī's headdress and took his chains and bow and arrows. Then he would go to different places in Sikkim (informant 6). He left once to meet the 16th Kar ma pa in bKra shis sding. The rGyal ba Kar ma pa had indeed come to bKra shis sding and expressed the wish to visit Chathak Rinpoche in Mangthiang. But he finally did not go for a reason which is unknown (informant 7 supposes that Chathak Rinpoche dissuaded him to come to such a remote place). Therefore, Chathak Rinpoche went to bKra shis sding where he appeared suddenly at midnight. He then met the Kar ma pa and other *Rinpoche* who were present. The meeting was witnessed by mKha' 'gro Padma bde chen (rDo grub chen Rinpoche's consort). Chathak Rinpoche then left, vanishing at the monastery's gate (informant 7).

He also used to recite *rDo rje gcod pa* at crossroads with a very loud voice while sitting on a flat stone. Passers-by were usually surprised and some bowed down in front of him (informant 6).

Chathak Rinpoche taught his eldest son his way of practising. He mainly taught him to recite *rDo rje gcod pa*, but did not encourage him to join a monastery. He indeed told him, "It is very difficult to become a good lama in a monastery, don't do it. You have to recite the *ma ni* mantra with a compassionate heart and *rDo rje gcod pa*; then there is no need for you to go to a monastery" (informant 6). Concerning *rDo rje gcod pa*, Chathak Rinpoche used to say, "It is the simplest and the most precious one can do." But the eldest son had interest in religious practices and learnt reading and writing from local lamas.

When at home, Chathak Rinpoche received visitors coming from all over Sikkim (informant 1 saw visitors from Singyang, Gangtok, Nam rtse and Kalimpong). He was usually asked advices to cure sickness and to forecast the future but he did not perform rituals for laymen. He also had donors (Tib. *sbyin bdag*) - though only a few of them - because many did not recognize his power or were afraid of this half naked man wearing chains (informant 1). Soshing Yapla was one of Chathak Rinpoche's donors and after Rinpoche passed away, his family became mTshams po Rinpoche's sponsor. Informant 1 saw Barmiok and Rhenock Athing coming to visit Rinpoche. Pedak lama from Tikja (Captain Sonam Yongda's father) was also one of Chathak Rinpoche's sponsors. He had requested Chathak Rinpoche's help with a ritual to get a son, which led to Captain Yongda's birth. Pedak lama and his wife used to come to visit Chathak Rinpoche in Mangthiang, bringing bags of rice. Until Chathak Rinpoche's death, Captain Yongda's family sent rice every year to Chathak Rinpoche (according to one of Captain Yongda's sons). Until today, Chathak Rinpoche is Captain Yongda's 'root master.' According to Captain Yongda's family, Chathak Rinpoche has other donors in rGyal shing area. People from Nam rtse also visited him (informant 1) and, according to informant 8, Chathak Rinpoche's relationship with his donors from Nam rtse dated back to his first visit to Sikkim. Then, Chathak Rinpoche shot an arrow from Gangtok to Nam rtse and the arrow hit Nam rtse Kazi's house. Since this time, the Kazi was his sponsor.

Chathak Rinpoche's chains

These chains have already been mentioned several times. There are several versions concerning their origins and what they became. According to most informants, Chathak Rinpoche was wearing them

when he arrived in Sikkim. Tshering Wangchuk Barphungpa heard Chathak Rinpoche's devotees saying that, as Rinpoche was the incarnation of Thang stong rgyal po, he was in possession of one of the chains originally created by Thang stong rgyal po, which he wore as protection (Tib. *bsrung bo*). These chains were made of very precious metal.

A story related to Nam rtse Kazi gives another explanation for Chathak Rinpoche wearing chains (it is told by an informant who does not wish to be named). It also shows that Chathak Rinpoche's relationship to this kazi might not have always been peaceful. Nam rtse Kazi (born in 1893) was the lord of the estates of Nam rtse and Lasso (he was also known as Lasso Athing), which included sGang rgyab. The settling of Chathak Rinpoche in sGang rgyab started a dispute with the kazi over land or taxes. Most probably, the kazi asked Chathak Rinpoche to pay taxes, which he refused. Nam rtse Kazi therefore summoned Chathak Rinpoche to court in Nam rtse. The case went on for sometime and Chathak Rinpoche often had to go to Nam rtse. He would walk very fast, halt in Soshing Yapla's house for food and, upon arrival at the court, would knock his trident on the floor to announce it. Eventually, the dispute grew bitter and the kazi had Chathak Rinpoche enchained. Then Chathak Rinpoche kept the chains, most probably as a testimony of the kazi's oppressive power and disregard for religion. He may also have cursed the kazi's family. It is unlikely, however, that Chathak Rinpoche started to wear chains only after his dispute with Nam rtse Kazi—most of the informants indeed say that he came with them to Sikkim—but the court case story seems genuine.³¹

At the end of his life, Chathak Rinpoche was no longer wearing chains. According to informant 5, they were brought to a Tibetan blacksmith in Rum theg to be melted in order to make ritual instruments. But the metal would not melt so the chains were left aside. Eventually, the rings got scattered and lost. Tshering Wangchuk Barphungpa heard another explanation which could be about the event from which informant 5's version originates. The story says that the stone carver of bKra shis sding, mGar ba Lama,³² requested sGang rgyab mTshams po Rinpoche—Chathak Rinpoche's eldest son—to donate his father's chains to be put inside a *mchod rten* (as *gzungs* or 'mystic formula') which was under construction at Rum theg and was

³¹ More extensive research may uncover the archives of the court case as every kazi kept records of their judgements.

³² *mGar ba* means 'blacksmith,' which could have led to the idea that the chains were to be melted.

being consecrated by the 16th Kar ma pa. mTshams po Rinpoche then offered most of his father's chains, but rings from Chathak Rinpoche's chains can still be seen in several people's houses in Sikkim.

The end of a religious lineage

Chathak Rinpoche passed away in the Earth Dog year of 1958 (informants 1, 2 and 4) at Palegang. His dead body was cremated near his house and a reliquary (Tib. *sku gdung*) was built by his family at the cremation place. This *sku gdung* is now abutted by those of Rinpoche's wife and first son. It is believed that Chathak Rinpoche was the last incarnation of his lineage and will not be born on earth again. Informant 1 comments, "He went to 'pure land' (Tib. *zhing khams*) and will not be back because he completed his work on earth." After meditating at the request of Chathak Rinpoche's son-in-law, the 16th Kar ma pa also realised that Rinpoche had gone to a 'pure land' (informant 7). Even Chathak Rinpoche himself had wished on more than one occasion that he would not come to Sikkim again, probably due to the severe hardships he had to face there coupled with constant harassment by law enforcers and the cold attitude of the locals shown towards him, mainly during the last part of his life (informant 7).

Informant 6 explains, "Usually, a lineage is enthroned in a monastery, but Chathak Rinpoche's first son said that his father will not incarnate again and that, therefore, there is no reason to build a monastery."

CONCLUSION

The passage of time has obviously transformed Chathak Rinpoche's life story. Few direct witnesses could be found and no direct descendants of Chathak Rinpoche could be interviewed. The first consequence of the passage of time has been to make Rinpoche more famous today than he ever was during his lifetime. Indeed, at that time, very few people knew about him mainly because he was living in a remote area of Sikkim. He was conscious of this as he asked his visitors, "Why did you come to this monkey's land?" a question heard by Tashi Densapa. This process of popularisation is supported by his family whose several members have gathered information about Chathak Rinpoche, sometimes publishing it in the newspaper, while others wish to write a book about him.

Secondly, the impression that some events of Chathak Rinpoche's life are today exaggerated cannot be avoided—which does not mean

that Rinpoche was not an achieved Buddhist practitioner or did not have any special abilities. The narrations presented here mainly inform us about the creative process of a modern time legend defined as a narration. Its subjects are real but perhaps transformed and made more attractive and even mingled with magic. Chathak Rinpoche's life story indeed presents an important feature of the legend: different versions of the parts of this legend exist, but often some details are described with great precision and remain unchanged from person to person—like the ogresses' dialog or the arrow shot on the door of gSang yum's meditation house—while the context of the narration remains uncertain.

Several elements of the narrations about Chathak Rinpoche nevertheless show that he shared common features with the figure of the Tibetan 'saintly madman,' one of those who "consciously echo the crazy behaviour of some of the Tantric siddhas of India,"³³ one of whom was his previous incarnation, Saraha. With the 'saintly madman', Chathak Rinpoche shared at the very least his bizarre mode of dress, his disdain for scholasticism, and probably his disregard for social hierarchy³⁴ as demonstrated by his marriage to a Lepcha woman and his resistance to the kazi. No account shows that he had disdain for social conventions, like the Tibetan 'saintly madmen,' but his appearance was uncommon enough to raise fear among common people. Mentioning the only photo that was taken of Rinpoche, informant 1 comments, "At least, for the photo, he has put something on his waist." Moreover, informant 6's version shows that Chathak Rinpoche was first considered a foreigner, at least by his future father-in-law. Therefore, his strangeness was double.

Chathak Rinpoche also shared with the 'saintly madmen' his great attainment, demonstrated by his powers. He could indeed walk extraordinarily fast, predict the future, cure illnesses, see through people, tame demons, etc. He was then seen as a holy man rather than as a crazy one.

The form of Buddhism that developed in Sikkim—the dominant form of Buddhism in Sikkim is one of the least monastic among the forms of Tibetan Buddhism, or the most involved in the worldly domain, without being much challenged by other forms which are almost not present in the State—allowed Chathak Rinpoche's transformation from stranger to holy man. Sikkim is also seen as a great holy place and attracts all kind of practitioners, but Chathak Rinpoche did more than visit. His link with Guru Rinpoche that I mentioned

³³ G. Samuel, 1993: 303.

³⁴ *Ibid.*

earlier, as well as his building of *mchod rten* and thrones at specific locations, as well as his transmission of the power of his body to its realisations, putting his chains inside, allow me to recall the link between the yogī's body, the right location of practice and the web of pilgrimage sites made by Sondra L. Hausner.³⁵ This author indeed stresses the importance of finding the right place of practice for the yogī to attain realisation. "The physical place of practice and the actual seat if the *yogī* gains importance through the concentrated energy of the *yogī* and that of those who have meditated there in the past. Further, these seats of practice are connected with a web of pilgrimage sites containing additional seats of practice."³⁶ Chathak Rinpoche added his own web of pilgrimage places to the holy land of Sikkim.

BIBLIOGRAPHY

- Dawa Gyatso Mawepa. 2005. The real story of Simuzum, *Now!* 23 April, Gangtok.
- Gyatso, J. 1979, The Teachings of Thang-stong rGyal-po, in Aris, M. and Aung Suu Kyi (Eds), *Tibetan Studies in Honour of Hugh Richardson, Proceeding of the International Seminar on Tibetan Studies*: 111-119, Warminster: Aris and Phillips.
- Hausner, Sondra. 2006. The Erotic Aesthetics of Ecstatic Ascetics, in Linrothe, Rob (ed.), *Holy Madness: Portraits of Tantric Siddhas*, New York: Rubin Museum of Art and Serindia Publications: 164-177.
- mThu stobs rnam rgyal and Ye shes sgrol ma. 1908. *History of Sikkim*, English translation of 'bras ljongs lung bstan gsal ba'i me long, unpublished.
- Samuel, G. 1993. *Civilized Shamans: Buddhism in Tibetan societies*, Washington, London: Smithsonian Institution Press.
- Stearns, Cyrus. 2007. *King of the Empty Plain. The Tibetan Iron-Bridge Builder Tangtong Gyalpo*, Snow Lion Publication.
- Stein, R. A. 1951. Mi-nag et Si-hia, géographie historique et légendes ancestrales, *BEFEO*, XLIV, 1 (1947-1950): Paris, Hanoï.
- Stein, R. A. 1981. *La civilisation tibétaine*, Paris: le Sycomore, l'Asiathèque.
- Young, Serenity. 2007. Review of *Holy Madness: Portraits of Tantric Siddhas*, ed. Rob Linrothe. *Journal of the International Association of Tibetan Studies*, no. 3 (December 2007): 1-8. www.thdl.org?id=T3132.

³⁵ 2006.

³⁶ Serenity Young, 2007: 4.

ANNEXE 1: THE INFORMANTS

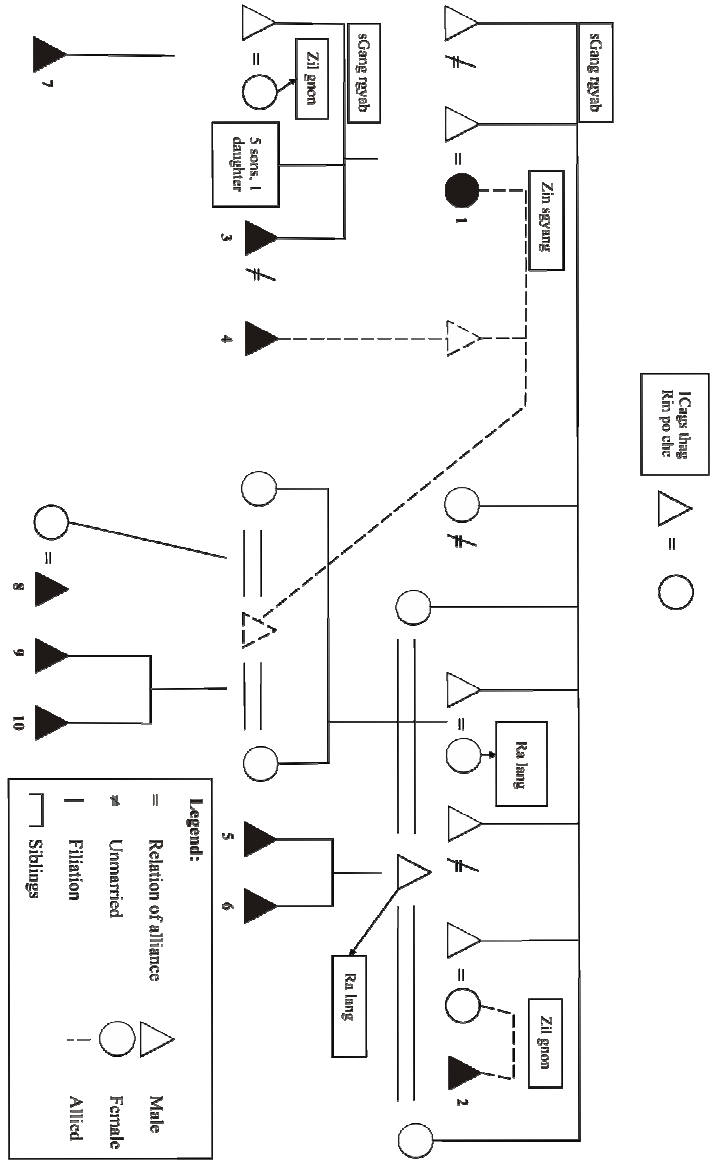

Annexe 2: A text about Chathak Rinpoche³⁷

ལྟུགས་ཐག་རྩོམ་པོ་ཚེ་ལྷོ་བའི་ཐུགས་རྒྱུ་མྱེ་ཏུ་ལྷོ་ཤོ་རྩོམ་ཚེ་ལྷོ་ལྷོ་ལྷོ་ལྷོ་
 བུ་འདྲུ་ལྷོ་ལྷོ་ལྷོ་ལྷོ་ལྷོ་ལྷོ་ལྷོ་ལྷོ་ལྷོ་ལྷོ་ལྷོ་ལྷོ་ལྷོ་ལྷོ་ལྷོ་ལྷོ་ལྷོ་
 ཚེ་ལྷོ་ལྷོ་ལྷོ་ལྷོ་ལྷོ་ལྷོ་ལྷོ་ལྷོ་ལྷོ་ལྷོ་ལྷོ་ལྷོ་ལྷོ་ལྷོ་ལྷོ་ལྷོ་
 ལྷོ་ལྷོ་ལྷོ་ལྷོ་ལྷོ་ལྷོ་ལྷོ་ལྷོ་ལྷོ་ལྷོ་ལྷོ་ལྷོ་ལྷོ་ལྷོ་ལྷོ་ལྷོ་
 ལྷོ་ལྷོ་ལྷོ་ལྷོ་ལྷོ་ལྷོ་ལྷོ་ལྷོ་ལྷོ་ལྷོ་ལྷོ་ལྷོ་ལྷོ་ལྷོ་ལྷོ་ལྷོ་

ལྷོ་ལྷོ་ལྷོ་ལྷོ་ལྷོ་ལྷོ་ལྷོ་ལྷོ་ལྷོ་ལྷོ་ལྷོ་ལྷོ་ལྷོ་ལྷོ་ལྷོ་ལྷོ་
 ལྷོ་ལྷོ་ལྷོ་ལྷོ་ལྷོ་ལྷོ་ལྷོ་ལྷོ་ལྷོ་ལྷོ་ལྷོ་ལྷོ་ལྷོ་ལྷོ་ལྷོ་
 ལྷོ་ལྷོ་ལྷོ་ལྷོ་ལྷོ་ལྷོ་ལྷོ་ལྷོ་ལྷོ་ལྷོ་ལྷོ་ལྷོ་ལྷོ་ལྷོ་ལྷོ་
 ལྷོ་ལྷོ་ལྷོ་ལྷོ་ལྷོ་ལྷོ་ལྷོ་ལྷོ་ལྷོ་ལྷོ་ལྷོ་ལྷོ་ལྷོ་ལྷོ་ལྷོ་

³⁷ This text was found by informant's 7 in the old family house in Palegang. As it starts abruptly, it is likely that a first page was written, which has not been found in the house.

BUDDHISM IN THE HIMALAYAN BELT

P.K. GAUTAM

Institute for Defence Studies and Analysis, New Delhi

This paper shows how and why Buddhism is important for India and the India Himalayan belt. It covers historic roots, followed by analysis of select border regions.¹ Its central theme is the need to nurture Buddhism.

INTRODUCTION

What is the influence and importance of Buddhism on the Indian Himalayan belt? We can answer this question from many perspectives. As far as influence is concerned, Buddhism as practiced in the region has roots in India. It is practiced in the Indian Himalayan belt in Ladakh, and in border regions of Himachal Pradesh, Uttarakhand, Sikkim, and Arunachal Pradesh.² In neighbouring countries it is practiced in Tibet,³ mountainous regions of Nepal and most of Bhutan.⁴ This vast and linear region of harsh terrain, limited resources

¹ This paper is based on both a survey of written sources and interaction with leading Buddhist figures.

² According to 2001 census figures on Buddhism, proportion of Buddhist are 1.1% in J and K (1.13 lakhs), 1.2% in Himachal Pradesh (75, 859), 28.1% in Sikkim (1.52 lakhs), 13% in Arunachal Pradesh (1.43 lakhs) and 0.1% in Uttarakhand (12,434). However, the land area is much larger. Ladakh is one third of J and K. Buddhist border region of Arunachal Pradesh likewise stretches all along the Sino-India border. All are residing in strategic and sensitive border regions.

³ According to Ministry of Home Affairs *Annual Report 2008-2009*, population of Tibetan refugees in India is 1,10,095. Figures for Tibetans in TAR and other regions of China with Tibetan population on 2000 Chinese census data is 2.41 lakhs in TAR and 4.5 lakhs in all China. See *Encyclopedia of Contemporary Chinese Culture*, Edward L. Davis (ed.), London/New York, Routledge, 2005. According to exiled Tibetan website, there are 6.1 million Tibetans worldwide which included 20,000 in Nepal, 1,500 in Bhutan, 3,500 in the USA and Canada, 2,000 in Switzerland and a few elsewhere. See <http://www.tibet.com/index.htm> accessed in October 2008.

⁴ Nepal has 11% Buddhists in a population of 2.9 crores which is about 29 lakhs consisting of Gurungs, Tamangs, Sherpas, Newars, and Bhots. Bhutan has a population of 6.8 lakhs with 75% practicing Lamaism Buddhism. See, "Socio Economic Indicators" in Ashok K. Behuria (ed.) *Changing Political Context in South Asia: Implications for Regional Security*, New Delhi, IDSA, November 2008, pp.237-

and carrying capacity has found an ideal location of its practice. As far as importance is concerned it informs India's border relations with its neighbours such as China and Tibetan Autonomous Region (TAR), Nepal and Bhutan. The Tibetan spiritual leadership in-exile is now lodged in India. In Sino-India relations the Tibet factor has and will remain crucial. It is important to look at a religion which has for India, all the ingredients of what some political scientists call 'soft power'.

Historically, Indian Buddhist institutions such as Nalanda were the centres of excellence for propagation of Buddhist ideas. Indian influence and role was pivotal in the establishment of Mahayana Buddhism in Tibet. As an extant spiritual and soft power, this link is too important to be ignored. According to Ladakhi scholar and the Principal of Central Institute for Buddhist Studies Dr Nawang Tsering:

Students and pilgrimage kept rushing to Tibet in quest of learning Buddhist culture and language. They came from all corners of its ethnic regions of Mongolia, Bhutan, Nepal and the Indian Himalayan states for higher studies until middle of the 20th century when Tibet lost its independence in 1959. The upheaval in Tibet proved cultural setback not only for the Tibetans but also among its traditional cultural satellite regions and ethnic groups. Fortunately, the Tibetans received whole edifice of the Indian culture in general and Buddhism in particular before Buddhism disappeared from India in 12th century. In the same manner, the people of Indian Himalayan states received complete culture from Tibet before the Chinese Red Guards' destructive Cultural Revolution in 1960.⁵

Two events lead to near extinction of Buddhism from the plains of India. One account as given by Hiuen Tsang (Xuanzang) showed Buddhist crusades of Kumarila and Sankaracharya in the eighth century were potent factors in rendering Buddhism unpopular. The final blow was delivered by Muslim invaders. As one example, Muhammmad Bakhtiar Khalji in end of the twelve century, destroyed Buddhist religious infrastructure such as Nalanda. However, the knowledge and literature of Buddhism, rather than being available in India, was

272 and Pitambar Sharma, *Unraveling The Mosaic: Spatial Aspects of Ethnicity in Nepal*, Lalitpur, 2008. It has enduring friendly relations with India including Buddhist connections. See Maj Gen Y.K.Gera (Retd), "Developments in Bhutan," *The Journal of the United Service Institution of India*, Vol.CXXXVII, No.573, July-September 2008, pp.342-350.

⁵ Dr Nawang Tsering, "Why Bhoti Should be in the Eighth Schedule", *Border Affairs*, April-June 2007, pp.16-20.

reserved or we can even say got ingrained and further developed in Tibet before it got eliminated in India.⁶

The pendulum so to speak swung back. In mid-twentieth century, when the People's Republic of China (PRC) took over Tibet, that very knowledge pool came back to India with the Tibetan exiles. There is a need to revisit the aspect of how religious wisdom originating from India has now virtually lodged back in India with the Tibetans in exile.

Besides, in recent times, a new trend is emerging with international dimensions: more and more Westerners and people across continents are also getting attracted to Tibetan Buddhism. It is getting truly globalised. What is unique is that India is now in the stage where it can facilitate the consolidation of this great religion—which was born in India and its Mahayana version in the Himalayan belt including Tibet was the result of the hard work and influence of Indian monks, philosophers and travellers in the past such as Nagarjuna, Santaraksita, Padmasambhava, Kamalsila, Atisha Dipankara, Tilopa, Naropa and others. It must be acknowledged that the Indian state in present times has given all the possible support to preserve Buddhism. There is a new momentum. Institutes as centres of learning and preservation of the Buddhist culture exist in the Himalayas like the The Central Institute of Buddhist Studies, Ladakh, in the west to the Namgyal Institute of Tibetology, Gangtok and Central Institute of Himalayan Culture Studies in Arunachal Pradesh in the east. In mainland India in the plains, many universities have departments of Buddhist studies. The Varanasi based Central Institute of Higher Tibetan Studies (CIHTS) envisioned by Pandit Jawahar Lal Nehru in consultation with His Holiness the Dalai Lama, was established in 1967 with a view to educating the youths of Tibet and Himalayan border students of India. It is now an autonomous body under the Department of Culture, Ministry of Education, Government of India. The institute is achieving its goal of excellence in the field of Tibetology, Buddhology and Himalayan Studies. Another university of repute is the Sampuranannd Sanskrit University at Varanasi. A synergy exists with other seats of learning set up or under consideration by the Tibetans in India. The new Nalanada university planned will also provide momentum.

It may be admitted that unlike PRC which according to some accounts is “fast assuming the leadership role of the Buddhist world”⁷

⁶ Suniti Kumar Pathak, *The Indian Nitisastras in Tibet*, Delhi, Motilal Banarasidas, 1974. Likewise, after expulsion from India, like Mahayan Buddhism in Tibet, in Sri Lanka Theravada Buddhism has flourished.

⁷ P. Stobdam, “Chinese Checkers” IDSA web commentary of June 13, 2008.

no long-term strategic thought has been given to India nurturing and then using this spiritual and cultural power to its advantage. In the Indian context both the state and society have to play a mutually supportive role. The state needs to facilitate the religious practices and make institutions that benefit the minority community besides suitable economic development. At the same time the people in the so called periphery have to be willing partners in nation building. This willingness is contingent on both top down policies by the state and bottom up people's participation.

With capitalism, it is possible that there may be strong revival of religion in China. Tibetan Buddhism already exists in the region. Will PRC encourage spread of Buddhism and religious freedom? It is very unlikely. Thus to recapitulate the roots of this religion, seeing how it is being practiced in present times, both by Tibetans, Indians and other nationalities in the strategic Himalayan borderlands may give us fresh insights on a soft power which we may need to be nurtured.

Four regions have been covered as a sample case for the study—Ladakh, Gangtok, Siang region of Arunachal Pradesh and Kameng and Tawang.

PART I : LADAKH

General Information on Ladakh

It needs to be noted that Buddhism first came to Ladakh via Kashmir in first century AD, well before it had reached Tibet. Later with conversion of Kashmir to Islam and expulsion of Buddhism from India it spread to Tibet. Tibet in turn under influence of Indian monks, sages and the university system of Nalanda and the like adopted Buddhism. Tibet became the centre of the faith. In a survey in 2004, in seven monasteries in Ladakh there were 96 elderly monks who had been to various monasteries in Tibet before the take over by the Chinese.⁸

Monasteries

Ladakh has about 37 monasteries of different traditions spread out in the Leh Valley along the Indus River from the international border till short of Kargil, Zaskar region, Nubra Valley and Chushul region.

⁸ Sonam Joldan, "Traditional ties between Ladakh and Buddhist Tibet: Monastic organization and monastic education as a sustaining factor", *The Tibetan Journal*, Vol.XXXI, No.2, Summer 2006, pp.69-88.

Broadly there are four traditions⁹ with representative monasteries as under:

- a. Nyingma. The oldest tradition founded by Padmasambhava.
- b. Kagyu. In Ladakh it has two prominent sub-traditions. The Changpa nomads of Durbok follow the Dri-Gungpa tradition and those of Nyoma block follow Drug-pa tradition.
- c. Sakyas.
- d. Gelug, the dominant tradition in Tibet, and that of the Dalai Lama.

It must be appreciated that with influx of foreign tourists and devotees the ambience is of a very high spiritual order. What was striking was the 14th Dalai Lama's photograph was found in all traditions. He also had inaugurated some work in monasteries and had visited nearly all of them.

Mahabodhi International Meditation Centre, Choglamsar

This is a new centre set up by a former Ladakh Scout soldier Bhuikku Sangasena in 1986 who chose monkhood. It has an impressive campus with most of the young employees from Ladakh. This centre is a new variation in Buddhist practice including Theravada and has opened up the religion to the common man as an NGO of charity and inter-religious and inter-cultural dialogue. It has great potential to strengthen the religious practices of the people of Ladakh.

Central Institute of Buddhist Studies, Choglamsar

The Central Institute of Buddhist Studies (CIBS), Choglamsar is now in its new sprawling campus. The Principal Dr Nawang Tsering is a regular contributor to the journal *Border Affairs* on issues of Bhoti language and the trans-Himalayan nature of Buddhism. The institute is impressive and is propagating Buddhist religion, art and culture. The institute is under the Ministry of Culture, Government of India. Overall there may be about 1400 lamas in schools in Ladakh. At CIBS, out of 600 student population 50% are lamas. An important point that emerged is the "Nalanda System of Religion" that informs Buddhism in

⁹ One thing that I have gathered from my interactions with Buddhists is that they do not consider the traditions as exclusive or divisive. Though in Tibetan history, there was violent struggle this is no longer the case. I thank Professor Hira Paul Gangnegi of Department of Buddhist Studies, Delhi University in emphasizing that it will be apt to call them 'traditions' rather than 'sects'.

these parts. Also the climate, terrain and environment are conducive for Buddhism.

People of Ladakh

The Buddhist border region of Ladakh also provides troops for the famous Ladakh Regiment of the Indian Army. The people have lived up to their reputation in defending India from aggression both against China and Pakistan. In this region Buddhism and lifestyle is integrated. Rapid changes are underway. The crisis is now upon settled agriculture. Unintended consequences have emerged due to population control policies. They have been counter productive in Ladakh. With one or two child norms, Ladakh is now suffering. Farm labour is less. So much so that Nepali and Bihari casual labour is being employed. Service sector is luring people with false hopes. Too much of “market forces” is not a good thing as ecology can not be left to flourish under market forces.

Another change is sedentarisation of the nomads—the most pristine form of nature worshipers who have adapted to Buddhism—the ones who dwell in the harsh border regions. Dr Tsering Phuntsog, District Sheep Husbandry Officer, Leh had carried out research on the political economy of the nomads of Changthang region in both Tibet and Ladakh.¹⁰ According to him, there are about 13,000 Indian citizens and 3,500 Tibetan refugees (Changpas) practicing this nomadic lifestyle in the harsh and high altitude regions of Ladakh. Absence of monasteries in the region is itself proof of the harshness of the environment. Grasslands are reducing and grazing is getting affected due to many reasons. The Changpas still follow a mixture of Bon religion practices with Buddhism, which is very close to their deep understanding of nature and the domesticated animal kingdom. Primarily it is the Pashmina goat wool that is their product. This is a neglected field and much more can be done for the Changpas. Due to hard life they are migrating and settling down in urban areas such as Leh even for menial jobs. The animal population had increased but the number of people fending for them has decreased. This shows that if correct policies are framed it can be a profit making enterprise. In a survey, their priorities were children’s education, jobs, and health. Animal related issues were last in priority. Animal husbandry and agriculture, which were central

¹⁰ Tsering Phuntsog, “Changing needs to balance continuity and change”, *Border Affairs*, January – March 2008, pp.19 – 28, “Best So Far Has Not Been Good Enough”, *Border Affairs*, April – June 2008, pp. 15-33 and discussions.

to the traditions of Ladakh, are on the decline. Due to imported goods like down jackets, the market for local products of wool has gone down.

It is with the tolerant and evolved Buddhist practices that the people of Ladakh are prospering. Unlike the unresolved land reform issues in mainland plains of India, Buddhist practices of people willingly contributing to monasteries who have a large land under their influence is fundamental to understanding the influence of Buddhism. After partition, while getting rid of the zamindari system, the powers that be also thought fit to implement it in Ladakh. The people agitated. The Wazir Committee was formed which underlined the role of monasteries and how people willingly contribute their produce.¹¹ Such lessons should not be forgotten and one-fits-all solutions by policy makers may create more problems. Now there is a need to be sensitive to the changes being brought about by economic growth. Changes are bound to impact also on the way Buddhist practices relate to nature.

Economic prosperity has also led to greater awareness and modern education. The new set of Ladakhi intellectuals are now helping Ladakh to develop and realize its potential. Rather one can sense the emergence of a Ladakhi identity which may no longer consider the past Hindu Dogra rule or the dominance of Tibetan Buddhism as central.

PART II: SIKKIM

General Information on Gangtok (Sikkim)

Sikkim became the 22nd state of India in 1975. The 2001 census placed its population at 5.40 lakhs. It has now been made one of the eight states of North East India. It has majority Indians of Nepalese descent (70% mostly Hindus) with Bhutia (mostly in north Sikkim – Lachenpas and Lachungpas 16%) and Lepchas (14% who are followers of the Nyingma tradition) making up the balance.¹²

¹¹ R.S. Mann, *Ladakh Then and Now*, New Delhi, Mittal Publications, 2002, p.294.

¹² P.N. Chopra, *Sikkim*, New Delhi, S. Chand and Co. Ltd, 1972, Reprint 1985, p.45. According to Tashi Topden extant colonial data of gazetteer is inaccurate on Sikkim. See Tashi Topden, "History and the Loss of Sikkimese Culture" paper presented in the Golden Jubilee Conference of the Namgyal Institute of Tibetology in October 2008, Gangtok, Sikkim on *Buddhist Himalayas: Studies in Religion, History and Culture* (forthcoming).

Though Sikkim may not be a Buddhist majority state, its culture and ethos, more so in the border regions, is closely integrated with Mahayana Buddhism.

Namgyal Institute of Tibetology (NIT)

The importance of Buddhism in Gangtok gets further fortified by institutes such as the Namgyal Institute of Tibetology. The NIT is envisioned as a storehouse of collective wisdom of all sects of Mahayana Buddhism. It was established during the reign of Chogyal Tashi Namgyal. Its foundation stone was laid by HH the 14th Dalai Lama in 1957. It brings out *The Bulletin of Tibetology* bi-annually. Nearby are the Do-Drul Chorten, built in 1948, and the Sikkim Institute of Higher Nyigma Studies (affiliated to Sampurnanand Sanskrit University, Varanasi), where young men imbibe teaching of the Nyingmapa tradition of Buddhism and acquire various degrees like Madhyamika, Shastri and Acharya.

The Golden Jubilee Conference of the Namgyal Institute of Tibetology (NIT), Gangtok, Sikkim was held from 1 to 5 October 2008 with the title *Buddhist Himalayas: Studies in Religion, History and Culture*. Undoubtedly, the NIT is emerging as an international nodal point for Tibetology and related studies. This will be in consonance with the *North Eastern Vision Document*¹³ which suggests that Sikkim can be developed as a hub linking other Buddhist destinations in Nepal, Bhutan, TAR, and Tawang to a pan-regional Buddhist circuit.

Division Within and Among Traditions

Without a mention of Rumtek, the survey is incomplete. This monastery of Tibetans-in-exile near Gangtok was in the media highlights when the teenaged 17th Karmapa Ogyun Thrinley Dorje fled to India from China in 2000.¹⁴ He was endorsed as a reincarnation (tulku) by the 14th Dalai Lama after the death of the 16th Karmapa in Chicago in 1981. Regents looked after the baby boy till he was grown up. Thus by 2000 or so the problem came to public scrutiny. India gave formal permission to him to be registered as a Tibetan refugee. There is also a rival candidate. The other rival camp within the sect had installed their own 17th Karmapa named Thrinley Thaye Dorje. When interacting

¹³ *North Eastern Region: Vision 2020*, Ministry of Development of North Eastern Region, May 2008, pp.131-132.

¹⁴ Anil Mahaeshwari, *The Buddha Cries!: Karmapa Conundrum*, New Delhi, UBS Publishers, Second Reprint, 2008.

with monastery information office, it was mentioned that there is even a third claimant. The Dalai Lama's endorsement, however, is generally final.

Rumtek monastery is the repository of precious gold, ashes of the famous and respected 16th Karmapa with his distinctive black hat.

As regards Karmapa and his tradition, most analysts who wrote in the New Delhi-based media when Karmapa escaped to India in 2000 considered that this controversy involves a security risk, as people of Sikkim will be affected as they follow this sect. However, most Sikkimese are followers of the Nyingma tradition. What security impact the Karmapa struggle will have thus may not be that serious for the locals. Interaction with Principal of CIBS at Ladakh also revealed that in Ladakh there is no impact on the society in Ladakh with politics related to Karmapa.¹⁵

In the larger study of Buddhism in the Indian Himalayan belt, perhaps one answer which lays to rest concerns for the extant continuation and resilience of Buddhism was provided by Principal, CIBS when posed this question. He answered that it needs to be remembered that Buddhism has survived since ancient times of Kushan and will continue to do so.

PART III: SIANG REGION OF ARUNACHAL PRADESH¹⁶

Peopling of the Region

Arunachal Pradesh is home to 26 major tribes scattered in 3,649 villages. Population of the state in 2001 census was about one million with population of upper Siang over 33 thousand (the ratio of scheduled tribe to general category is 78% : 22%). Broadly, the entire population in the Siang region (consisting of three districts of East, West and Upper Siang) bordering Bhutan could be divided in two groups based on their socio-political-religious affinities.

¹⁵ According to media reports of 2008, the Indian government has not allowed the 17th Karmapa Ogyun Thrinley Dorje to visit Tibetan Buddhist dominated areas close to the border of TAR due to the sensitive nature. However, in September 2008 he did visit Leh (Ladakh) and due to heavy snowfall was even rescued by military helicopters on the Upshi Manali axis beyond Barlachla pass. He is presently in his temporary abode at his monastery at Sidhbari near Dharmsala in Himachal Pradesh.

¹⁶ Entry to the state by Indian nationals is governed by the Inner line Regulations. Other states having the inner line regulation are Nagaland and Mizoram. Foreigners have to obtain restricted area permits.

The first are the Adis who reside in the middle belt. They worship and recognize Donyi (Sun) and Polo (Moon) or Donyi-poloism. The second group is that of the Buddhists like the Khambas and Membas who like other Buddhist communities of the Indian Himalayas live near the border with Tibet. To maintain their Buddhist connections, children from these regions get educated in schools and institutes of Mahayana Buddhism all over India.

PART IV: WEST KAMENG AND TAWANG DISTRICTS OF ARUNACHAL PRADESH

In this region if the second half of the twentieth century was a period of military build up and war with China in 1962, early twenty-first century history is centered around the consolidation of Buddhism with an Indian touch. This is borne out by the institutions, and cultural and religious infrastructure.

Central Institute of Himalayan Culture Studies (CIHCS)

The CIHCS at Dahung was established in 2003 under the Ministry of Culture and is affiliated to Sampurnanand Sanskrit University (SSU), Varanasi. It has about 130 students from all over India. It starts from class 9 onwards. It is a landmark institute and has a bright future. What is important is that it has highly motivated and dedicated Indian teachers hailing from all over the Himalayan belt including Tibetans and teachers from the Indo-Gangetic plains of the Hindi belt. Its dynamic principal Shri Geshe Ngawang Tashi Bapu (Lama Tashi), was born in Kameng District and had his Buddhist education in Karnataka in the Tibetan establishment located at Drepung Loseling Monastery at Mundgod, Karnataka. He is also former Principal Chant Master of the Dalai Lama's Drepung Loseling Monastery in India—one of the largest Tibetan Buddhist monasteries in the world, with over 3,000 monks. He has travelled extensively throughout the world, teaching, performing, and recording with monks from his Monastery. He was nominated for a Grammy Award for his path-breaking Tibetan chants in 2006 (available in CD).

CIHCS is an appropriate institution for preserving the culture. With a high level of leadership and devotion, the experiment has lots of potential. Rapid changes in society need to be balanced with both scientific and religious education. Institutes such as these are the future of the region. Unlike public schools for the rich and the elite where

boys and girls are prepared to serve the urban world of service, industry, business and commerce—this Institute will serve the poorer sections of the Buddhist Himalayas. In doing so, it will also have to chart a difficult course which now lays before us due to urbanization, modernization and all sorts of raised expectations. How much of negatives it rejects and how much of positives of progress it absorbs is now the new challenge.

Monasteries

Upper Bomdila monastery was earlier in Tsona (now in Tibet) and has an Indian citizen as its head. The present head, HE the 13th Tsona Gontse Rinpoche, is a former Congress MLA, who is leading with the issue of granting the region 'Monyul' an autonomous status as in Ladakh. He has followers spanning India and Tibet. Unlike the general impression that only Tibetans are in the top hierarchy, Indian citizens from Kameng region are the top clergy. Today gompas in Upper Bomdila and Tawang are headed by Indians.

Civil – Military Relations in Tawang Region

Tawang Maitreya Diwas is organised by the Indian Army, District Administration and YUVA (NGO) at Tawang on a regular annual basis. It is an important annual event in fostering a good rapport and is much liked by the locals. It is also very useful for the military who can better understand the local culture and Buddhism. This event is followed by Buddha Mahotsav around November.¹⁷

Tawang War Memorial

This 1962 war memorial is impressive and a tourist attraction. The memorial is built as a traditional chorten on Buddhist lines. It was personally anointed by HH the Dalai Lama in 1998. This bonding of the Indian Military with the Dalai Lama has a great significance for the people of Tawang, Buddhism and the military. The military needs to be complemented in being sensitive to the culture. A number of war memorials have come up in the former NEFA battle zone and are aesthetically based on the Buddhist concept of chorten.¹⁸

¹⁷ The 8th Festival was held in early November 2008 which was attended by the Indian External Affairs Minister Shri Pranab Mukherjee. See http://www.outlookindia.com/pti_print.asp?id=631281 accessed on 13.11.2008.

¹⁸ 28 Infantry Division of the Indian Army has the Buddhist symbol of Vajra as its formation sign.

Demand of Union Territory Status to Ladakh, Mon Autonomous Region and Gorkhaland

One positive result of the Buddhist belt in the Himalayas which is of considerable importance to India both in terms of economics and security is that there has never been any insurgency in the region. All political demands have been resolved by peaceful means. However, what is of concern is the clash between the Ladakh Buddhist Association and Islam which began in the 1980s. It is unfortunate that Ladakh, which includes Muslim Kargil, now appears to be divided. Kargil district has a Muslim identity and Ladakh Buddhist. To preserve their identity the people of Ladakh in the late 1980s had agitated for Schedule Tribe Status and formation of Ladakh Autonomous Hill Development Council. Now some demand a Union Territory status.¹⁹ Resolving this issue is difficult but essential.

Since 2004, there is a demand for the creation of the Mon Autonomous Council for West Kameng and Tawang. This is led by Tsona Gontse Rinpoche.²⁰ From a purely Buddhist point of view it appears that the demand is to ensure cultural and religious identity. Like in Ladakh, the perceived threat may be of spread of other religions like Christianity or even Islam or reassertion of Hinduism in some form.

There is an ongoing agitation for Gorkhaland in the Siliguri region of Darjeeling district of West Bengal and neighbouring areas. The context of these demands are different and it will be incorrect to compare them. It appears that granting Mon Autonomous Region Status will benefit both the people and ensure the so called nurturing of Buddhism in this belt on the Sino-India border. Similarly Ladakh's case for a Union Territory is driven by a desire to preserve religious identity and must be accommodated in some form. As regards Gorkhaland, if it includes Sikkim, then even the existing Buddhist identity of Sikkim may get overwhelmed. This will have many

¹⁹ Thupstan Chhewang, "Vindication of Leh Agitation for UT", *Border Affairs*, July-September 2008, pp.23-25 and "2008 a Crucial Year for us in Ladakh", *Border Affairs*, April-June 2008, pp.5-10, Sonam Wangchuk Shakspo, "Ladakh and New Delhi Made for Each Other", *Border Affairs*, July-September 2008, pp.26-28 and Tsering Samphel, "Ladakh's Stirring Saga of Valour and Patriotism", *Border Affairs*, April-June 2008, pp.11-14.

²⁰ *The Hindu* (New Delhi), October 20, 2008. In the Patkai region the demand for an autonomous council is for Changlang and Tirap districts, probably due to the threat they perceive due to spread of Christianity with the political demands of Nagalim.

disadvantages as it is important to retain the Buddhist identity of Sikkim.²¹

Buddhism and Ecology

Another important influence of Buddhism is in ecological matters. We know how the fragile nature of the Buddhist Himalayan region has a complex relationship with and respect of nature. Buddhist values, lifestyles and expectations also preserve the ecology. Though the PRC claims it to be harmonious, economic development which is being carried out in Tibet is not in tune with the wisdom of the religion. Tibetan nomads who are now sidelined as far as their lifestyle or development is concerned are reported to have been the first one to notice changes in the land and weather around them.²² Climatic warming will spell disaster and so much is dependent on sustainable land use and respect for the environment. Desertification of open grassland and pastures, loss of biodiversity and over exploitation by way of resource extraction like water, deforestation, mineral extraction, etc., are appearing to be the new challenges. The Tibetans have pleaded for a Chinese Government rethink on development and environmental policies, be it settling of nomads, fencing of grasslands, reforestation, infrastructure development, and urbanization.²³

There is an urgent need for environmental degradation to be controlled in Tibet as it is the 'water tower of Asian' as all major rivers emanate here. To this end, the study indicates that there is an ecological aspect to the importance of Buddhism in the Himalayan region including Tibet. The carrying capacity of the Himalayan region is low and it is not possible for it to support a greater density of population. Bhutan being a small country has some policies such as gross national

²¹ It needs to be appreciated that some scholars have opposite views. A.C. Sinha has argued for a Nepalmul majority 'Sukhim' (united Darjeeling and Sikkim) for reasons such: 1) it will be free of Bhutia heritage and will save New Delhi the embarrassment of creating a tiny state (Darjeeling), 2) it may appeal to emotions of West Bengal, 3) it will have a viable state for Nepamul Indians which will take care of language, culture and identity, 4) it will be strategically located between Nepal, Bhutan, Tibet and Bangladesh with strong links to the north-eastern region, and 5) it will be 'Indianised', free from the legacy of the Namgyal Sikkim. See A.C. Sinha, *Sikkim: Feudal and Democratic*, New Delhi, Indus Publishing Company, 2008, p.311.

²² Michel Zhao and Orville Schell, "Tibet: Plateau in Peril", *World Policy Journal*, Fall, pp.171-180.

²³ *Tibet 2003: State of the Environment*, White Paper, Central Tibetan Administration, Dharamsala, 2003.

happiness. Sikkim has a green and organic policy evident by billboards and bumper stickers, but population growth may make it difficult to implement. Seeing the interrelated nature of people and their environment, it is suggested that both from ecological and Buddhist perspectives, the inner-line status quo, restricting population and influx by special status continues to be maintained in the Indian Himalayan belt.

Summary on Buddhism in the Region

Buddhist religion and culture is being vigorously pursued by Indians along the Himalayan belt. What is important to understand is that besides Tibet having an area half that of Europe and one fifth that of China, its population of six million (60 lakhs) dwarfs that of the Indian Buddhists in the Himalayas which varies from seven lakhs (census figure) to 22 lakhs as assumed by one author.²⁴ Thus any discourse on Buddhism or Tibetan Buddhism of the Mahayana variety can not ignore these vast regions of Tibet and their people.

Lama Tashi, the Indian monk and principal recalls that he owes all his training in Buddhist practices to the 'Harvard' of India at Mungod, north Karnataka (Drepung Loseling Monastery) where most of the teachers were Tibetans. What he implied was that a sprinkling of Tibetans monks and scholars had led us to enrich the culture and preserve this knowledge.

Relative Position of India and China

There are two different narratives in China and India. To preserve the culture and to let people develop according to their genius India restricts non-tribal people from settling down in the strategic Himalayan states according to Indian constitution and laws. The concept of inner line is still maintained.²⁵ On the other hand, the Chinese carry out Hanisation of Tibet. One should not see this in purely material, economic and infrastructure terms. While India allows religious freedom, it is suspect in Tibet. As the March 2008 events (spontaneous demonstrations all across TAR and also neighbouring

²⁴ Nawang Tsering, op cit, note 5.

²⁵ Some Tibetan youth are known to have admired the Sikkim model and feel that Tibetans could flourish in a democratic pattern laid out by the Dalai Lama following the example of Sikkim, which is to some degree its own world, even if it is part of India. See Pico Iyer, *The Open Road: The Global Journey of the Fourteenth Dalai Lama*, New Delhi, Penguin/Viking, 2008, p. 219.

regions of China having Tibetan population) show, religion appears to be a very powerful factor in Tibet. How about Buddhism in China? Box A is one snapshot.

Box A

BUDDHISM IN CHINA¹

Introduction

Amartaya Sen shows how Buddhism went first to China from India. Buddhism later reached Tibet. The journey of Buddhism from India to China has been particularly notable in the case of Chan (dhyāna) which transformed to Zen in Japan. In Tibet Buddhism survived and thrived. In 792 AD there was a great debate in which the Tibetans accepted the Indian version of Buddhism rather than that of China. What is important to know is that it declined simultaneously in China due to Neo-Confucianism, and at the same time in India due to Hindu revival. Daoist (or Taoist) opposition to Buddhism also had strong element of Chinese intellectual nationalism and a sense of superiority of Chinese ways. For example, the early 4th century Daoist activist Wang Fu in his book claims that Lao-tzu, the semi-legendary founder of Daoism went on a civilizing mission to India and to influence Gautam Buddha.

It is the tradition of irreverence and defiance of authority which came with Buddhism from India that was singled out for a particularly strong chastisement in early anti-Buddhist criticism in China. Fu-yi, a powerful Confucian leader had complained about Buddhism to the Tang emperor which parallels the contemporary disorder generated by the present day Falungong.

New discoveries along the silk route in Dunhuang show the spread of Buddhism from China through Central Asia till it got replaced with Islam. In the twentieth century, communism officially put an end to established religion. Yet in the contemporary world, one book on Chinese Buddhism (Ling Haicheng, translated by Jin Shaoqing, *Buddhism in China*, China International Press, nd.) claims that out of the three types of Buddhism in the world (Han Buddhism, Pali Buddhism and Tibetan Buddhism), China is the main region of two (Han and Tibetan). It is paradoxical that an atheist country can take credit for owning two thirds of Buddhism.

The New Fad

Like the Dalai Lama's effort to create interest and fascination with himself, his cause, and his religion around the world, something similar is happening in China. A. Tom Grunfeld writes that "There is a similar phenomenon going on in China, where the government's attention to Tibet has resulted in a different sort of fad; an infatuation with things Tibetan, at times portraying Tibetans as 'noble savages' with curious ways. Tibetan traditional medicine has become very popular while young Chinese are 'dropping out' by leading 'hippy lives' in Lhasa."

India and China

The modern development of Buddhism in China is already being assisted by the Indian Government as can be seen by the parliamentary debate on building Indian Buddhist temple in China. The Joint Declaration of 21 November 2006 between Premier Hu Jintao and Prime Minister Manmohan Singh when the former visited India is reproduced below.

India must be proactive via the ancient Nalanda trail and the new network which is emerging including Himalayan belt and South East Asian countries, Myanmar and Sri Lanka. It is unlikely that Buddhism will encompass the whole of China, but its spread may lead to a better understanding of democratic rights and Tibetan autonomy in future. In any case the name Shangrila (imaginative name in the 1933 novel *Lost Horizon* by British author James Hilton) and Buddhist mythical concept of *Shambala* have already been innovatively used by China for tourism. In 2002, they have even renamed Zhongdian County as Shangri-La (Xianggelila). The bulk of tourists are domestic Han Chinese.

It needs to be seen if Japanese variation of Soka Gokai (which is now also popular in urban India) may also spread in China in the future. Falung Gong was suppressed as in Chinese history, secret sects and cults are eyed suspiciously. But this now cannot be said for Mahayana Buddhism and allowing India the opportunity to promote the religion in China.

India has nothing to lose in spreading monuments to China. Rather it will be useful to track the historic routes of Buddhism and attempt to have Asoka type pillars in China and neighbourhood through diplomacy.

PARLIAMENTARY DEBATE ON BUILDING INDIAN BUDDHIST TEMPLE IN
CHINA AND JOINT DECLARATION OF 21 NOVEMBER 2006

Q. 2145 BUILDING INDIAN BUDDHIST TEMPLE IN CHINA 07/12/2005

LOK SABHA
UNSTARRED QUESTION NO. 2145
TO BE ANSWERED ON 07.12.2005

2145. SHRI BRAJA KISHORE TRIPATHY:

Will the PRIME MINISTER be pleased to state:

- (a) whether India has an opportunity to build the first Indian Buddhist temple in China;
- (b) if so, the details in this regard; and
- (c) the extent to which Indian heritage is likely to be boosted in China as a result thereof?

ANSWER THE MINISTER OF STATE IN THE MINISTRY OF EXTERNAL
AFFAIRS (SHRI E. AHAMED)

- (a) Yes, Sir.
- (b) The decision to construct an Indian-style Buddhist Temple in Luoyang, China was finalized with the conclusion of a Memorandum to this effect during the visit of the Chinese Premier, Mr. Wen Jiabao to India in April 2005. Under this Memorandum, the Indian side would provide Rupees Five Crores to the Chinese side for the construction of the Temple, in addition to providing the Buddha idol and other accompanying material. The Indian side is also responsible for the architectural design of the Temple project, its blueprint, material specifications and landscape planning, as also architectural and expert supervision during the construction work. The Chinese side will provide land and also undertake the construction work. The design and the architect for the project have been selected by an Advisory Committee constituted by the Prime Minister. The construction work to be undertaken by the Chinese side is expected to begin in 2006.
- (c) It is expected that the Temple, once completed, will become an enduring symbol of the centuries-old cultural exchanges between India and China, of which Buddhism is an important and integral part.

Joint Declaration by the Republic of India and the People's Republic of China of 21/11/2006.

IX. Revitalising Cultural Ties and Nurturing People-to-People Exchanges:

29. The centuries-old cultural contacts between the two peoples provide a strong foundation for enduring friendship between India and China. The initiatives to rediscover these historical linkages and revitalise them in the present day context, including through an early completion of the Xuanzang Memorial in Nalanda and the Indian-style Buddhist Shrine in Luoyang, will further strengthen these bonds. The two sides agree to strengthen cooperation in the area of spiritual and civilizational heritage, discuss collaboration in the digitisation of Buddhist manuscripts available in China as well as the re-development of Nalanda as a major centre of learning with the establishment of an international university on the basis of regional cooperation. In order to promote greater awareness of each other's culture, the two sides shall organise a "Festival of India" in China and a "Festival of China" in India, with a joint logo. Detailed modalities in this regard will be decided by the concerned authorities through mutual consultations.

The other narrative is about India which on the other hand allows religious freedom. India is also preserving Tibetan Buddhism which now is lodged in India and is also the land of Buddha. When comparing the two narratives it is clear that this soft power factor with India is vital. Policy planners must be sensitive to it. Buddhism, then with this logic needs to be nurtured in the Indian Himalayan belt. It is no surprise that the Dalai Lama has mentioned Buddhism as a line of Defence by India. What he meant was surely that defence is not only a function of weapons and military power. Much like the contemporary discourse on broadening of security agenda to include non traditional threats, culture and religion also provide a soft power which military weapons of coercion cannot match, and which are available at a far lesser cost than military forces.

As regards ethnicity, it can be said that Indians should not sound apologetic for Indian citizens being ethnic Tibetans. India in any case is a mixture of many races, religions and people. A study of literature at Box B shows that there are very varied accounts of ethnicity.

ETHNICITY AND LITERATURE SURVEY
OF THE INDIAN HIMALAYAN BELT AND ITS RELATIONSHIP WITH TIBETⁱⁱ

There are a number of anthropological, social, cultural and political accounts on the complex nature of the ethnicity of the people in the Himalayan belt under study.

When the Dalai Lama fled to India, Jawaharlal Nehru the Indian Prime Minister stated in the Lok Sabha that, “We have large number of people of Tibetan stock living in India as Indian nationals. We also have some Tibetans émigrés in India” (Bureau of Parliamentary Research).

The various Tibetan type Buddhist people on the southern side of the Himalayan watershed in India and Nepal are broadly described as Monpas in Tibetan, meaning ‘ravine dwellers’ (Das, Gautam). The ‘Gyagar Khampas’ or Kinnauris, Spitis or Ladakhis are Indian citizens with Tibetan ethnicity or religio-cultural affiliations with Tibetans (Falcone and Tsering).

According to Kharat, a population of Tibetan race inhabits Nepal, especially the Tamang region, Bhutan, Sikkim and along the westward Himalayas and is also found in varying numbers in the hill districts of Garhwal, Kullu, Spiti, Lahaul, Ladakh, Kashmir and NEFA (Arunachal Pradesh). This shows there were many Tibetans who had settled in India much before the post-1959 events, living peacefully, while maintaining cordial relations with the local inhabitants of India. In the Tawang region many Tibetans were settled almost a century ago and hold Indian citizenship.

Linguistic Groups

According to Nawang Tsering (Tsering), Bhoti is the name of a language as well as the name of a class or tribe who speaks this language. It is the lingua-franca of the people of Mongolia, Bhutan, Tibet, Pakistan Occupied areas of Skardu, Nepal, and the Indian Himalayan region from Ladakh to Arunachal Pradesh. Bhoti language is also known as Tibetan language because central Tibet has been the nucleus of Bhoti culture and language for centuries.

Regarding the linguistic groups, according to the Central Institute of Indian Languages, both Tibetan and Bhutia languages are of Tibeto-Burmese origin like Manipuri, Boro, Tripuri and others (CIIL).

Recent scholarship (Huber) shows that the entire region of Siang to Kameng in Arunachal Pradesh can be divided into four linguistic groups: Kho Bwa, West Tani, East Tani and Mishmi. In the region of Subansiri and Siang, community structure is very complex. The Membas area has a heterogeneous population. They are also mixed with Khambas in the area of Gelling.

Ladakh

According to Dewan (Dewan), in Ladakh initially Aryan Dards followed Bon Chos. Later, some converted to Buddhism. Dards were squeezed in from the east by Mongolian people from Tibet. In an alternative theory, Tibetan nomads were first to arrive, followed by the Mon people of north India and eventually by the Dards. There are two distinct groups of Ladakhi population (Mann). Firstly are the the Ladakhi or Bhoto, Boto, Bhaota, Bodh, Bodpa, and secondly are the Mons and Dards. According to Fernanda (2007), Ladakh is regarded as part of 'ethnographic Tibet'. Mullik (1971) mentions that the whole of Ladakh, except the western end near Kargil, is ethnically similar to Tibetans.

Himachal Pradesh

The Anthropological Survey of India (ASI) on Himachal mentions that the Bodh, Bhot or Chanzang are primarily distributed in the Lahul and Spiti valleys. Though the history of the Bodh is not available, according to local accounts, those people of Tibet who came and settled here in the past i.e., prior to 1962 are called Bodh or Bhot, whereas those who came after 1962 are known as Tibetans (ASI, a).

Sikkim

In the case of Sikkim, the Anthropological Survey of India mentioned that Lepchas, the original inhabitants call themselves Rongkup or Muntachi Rongkup. Later in the book it is mentioned that Lepchas are known as 'Monpa' by Tibetans and are a Kirate tribe, while Bhutias call them 'Meris' (ASI,b).

Sinha alludes to Bhutia immigrants representing Tibeto-Burman stock, Tibetan culture, language and a combination of pastoral and semi-settled grazers. The Lepchas (in Nepali 'lap' is vile, and 'che' is speakers) call themselves Rong and are known to Tibetans as 'Mon-ba' or 'Mon-rik', referring to the people of Mon country—a general Tibetan name for the lower Himalayas, from Kashmir to Assam and Burma (Sinha).

The Sikkim Development Report by the Planning Commission in tracing the history mentions no historic records exist to show how Lepchas came to the region. They have their own language known as Rong. In 1642, Bhutia rule was established in Sikkim. Land monopoly shifted from Lepchas to Bhutias. Bhutias also promoted inter-marriages with Lepchas and converted the spirit worshippers to Lamaist Buddhism. The name Bhutia is derived from their original habitat 'Bhot' (Tibet).

According to Topden, a lot of research needs to be done at the grass root level. His critical appraisal of available accounts of Sikkimese history, especially in English language, showed how writings by British colonial civil servants, adventurers and soldiers were based on their own biased observations, translations from grossly inaccurate Tibetan texts and incorrect interpretations provided by local guides. The British's exposure to Himalayan Buddhism was also limited. Ignorance of social systems, customs and religious beliefs of the local people resulted in 'Tibetanised' versions of Sikkimese history, given the British's primary fascination with Tibet during that particular period. Early accounts also suffered from a total ignorance of Sikkimese language such as Lepcha. The absence of academic interest by local scholars has also resulted in a very superficial account of Sikkim. Scholarship needs to be encouraged in this direction (Topden).

Arunachal Pradesh

According to the *Techno-Economic Survey of NEFA* by the National Council of Applied Economic Research (1967), the local population consists of 82 Indo-Mongoloid tribes and sub-tribes. In Western Kameng it shows that the region is home of Monpas and Sherdukpens. Both tribes are Buddhist and are strongly influenced by Tibetan and Bhutanese culture, tradition and customs. In Siang, along the international frontier, the two Buddhist tribes are Membas and Khambas which resemble the Monpas of Kameng district.

What is of particular interest now is what B.M. Mullik (1971) has mentioned at page 94 on Siang District: "This big bend of the Tsangpo contained within it Pemako and Chimdru areas, the inhabitants of which were not Tibetans and who had more access to India than to Tibet. Even as late as 1959 petitions were filed by the people of Pemakao and Chimdru to the Government of India to take them under Indian administration."

According to Chowdhury (1983), ethnically the Monpas of Kameng might have affinity with the Bhutanese to the west and Tibetans across the northern borders.

In current government documents most of the people in Arunachal Pradesh are either Tibetan or of Thai and Burmese origin (North Eastern Region, Vision 2020). According to Keki N. Daruwala, the tribes in Arunachal Pradesh have migrated over centuries from the Mekong and Tibet. The Adis claim Tibetan descent (Daruwala).

Some just prefer to mention that Monpas and Sherdukpens of Tawang and West Kameng have close social and religious ties with the Tibetans (Das, Pushpita). In the case of Tawang and Kameng, to counter the Chinese claim, Indian scholars (Dutta) have gone on to argue that Monpas are not Tibetans and China can not claim the area on the basis of ethnicity or religion.

These arguments of denial of ethnicity are not convincing. Probably they are based on one of the initial official publications (Bureau of Parliamentary Research, page 38), which also emphasised this point. It was mentioned that the Monba, Aka, Dafla, Mir, Abor, Mishmi had no kinship ties with Tibetans. Rather the Tibetans refer to them as ‘Lopas’ – ‘southern barbarians beyond the pale’.

Conclusion

This survey establishes the incompletely researched, complex, multi-cultural, linguistic and ethnic composition of India in the frontier zone of the Indian Himalayas. The crux is that at no time should Indians be apologetic for having Tibetan stocks in their population. Rather, it is time we shed mongoloid prejudices all together. Priority is for an Indian identity followed by regional identities. However, more multi-disciplinary scholarship is needed to have the correct ‘data’ on our own people.

To consolidate this invaluable soft power, what needs to be done is to make further attempts to integrate the Buddhist Himalayan belt with national and international centres of learning and preserve and promote the Buddhist cultural heritage of India. As the evidence shows, Indian Buddhist institutions have a symbiotic relationship with those in Tibet. Buddhism is a common factor. With this logic, religious and cultural roots are integrated into the Indian Himalayan region through Buddhism. Thus even the exiled Tibetan Buddhists, the Buddhists in TAR and other regions of China, the Tibetan Buddhist Diaspora and Buddhists of the India Himalayan belt have much more in common with each other than Han Chinese with Tibetans. It is no surprise that after 50 years, Tibetans are never unwelcome in India. This as we show is due to the linkages of Buddhism.

In summary Indian diplomats, academics, military officers, scholars and citizens must be educated on the complexities of these issues. More research and publicity concerning the Buddhist regions of the Indian Himalayas is needed at an international level by the Indians.

Conclusion

This article has attempted to show the influence and importance of Buddhism in the Himalayan belt for India. The overlapping nature with Tibet and Buddhism as practiced in Tibet has also been shown to have entwined linkages with India. The twenty-first century should not be

like the twentieth with military conflicts with hard power tools. Rather, importance of soft power such as culture and religion can now be supplemented to enhance both national and human security of the people. The Indian state and citizens need to be made aware of these characteristics to nurture Buddhism in the Himalayan belt and beyond in Tibet.

ⁱ BOX A REFERENCES:

- Grunfeld A. Tom. 2006. Tibet and the United States, in Barry Sautman and June Teufel Dreyer (eds), *Contemporary Tibet*. New York: M.E. Sharpe.
- Haicheng, Ling. *Buddhism in China*, China International Press, nd.
- Lal, Dinesh. 2008. *Indo-Tibet-China Conflict*. Delhi: Kalpaaz Publications.
- Pan., Philip P. 2003. China's Hippies Find their Berkeley, *Washington Post*, Sept. 22.
- Sen, Amartya. 2005. *The Argumentative Indian*. London: Allen Lane.
- Topping, Andrew Ronning. China's heritage on the old Silk Road, *World Policy Journal*, Vol. XXV, No.4, Winter 2008/09.
- Kolås, Åshild. 2008. *Tourism and Tibetan Culture in Transition: A Place Called Shangrila*, Oxon: Routledge.

ⁱⁱ BOX B REFERENCES:

- Bureau of Parliamentary Research, Congress Party in Parliament, *India – China Border Problem*, New Delhi, 1960.
- Central Institute of India Languages, <http://www.ciil.org/Main/languages/Index.htm> accessed on 30 October 2008.
- Chowdhury, J.N. 1983. *Arunachal Pradesh: from Frontier Tracts to Union Territory*, New Delhi: Cosmo.
- Daruwalla, Keki, N. 2006. Photograph Ashok Dilwali, *Riding the Himalayas*, New Delhi: Nyogi Books.
- Das, Gautam. 2007. *Unlearned Lessons: An Appraisal of India's Military Mishap*. New Delhi: Har Anand.
- Das, Pushpita. Management of India-China Border Area: A Case Study of Arunachal Pradesh, *Indian Foreign Affairs Journal*, Vol.3, No. 3, July – Sept 2008.
- Dewan, Parvez. 2004. *Jammu, Kashmir and Ladakh*. New Delhi: Manas.
- Dutta, Sujit. Revisiting China's Territorial Claim on Arunachal, *Strategic Analysis*, Vol. 32., Issue 4, July 2008.
- Falcone Jessica and Wangchuk Tsering, "We're Not Home": Tibetan Refugees in India in the Twenty-First Century, *India Review*, vol.7, no.3, July – Sept, 2008
- Fernanda, Piere. 2007. *Peace and Conflict in Ladakh: the Construction of a Fragile Web of Order*. Brill: Leiden.
- Huber, Toni. (forthcoming). Pushing Southward: Tibetan Political and Economic Interests in the Far Eastern Himalayas, ca.1900-1950s. Paper presented in the Golden Jubilee Conference of the Namgyal Institute of Tibetology, Gangtok, Sikkim in October 2008 on *Buddhist Himalayas: Studies in Religion, History and Culture*.
- Kharat, Rajesh. S. 2003. *Tibetan Refugees in India*. New Delhi: Kaveri Books.
- Mann R.S. 2002. *Ladakh Then and Now*. New Delhi: Mittal.

-
- Mehra, Parshotam. 2007. *Essays in Frontier History: India, China, and the Disputed Border*. New Delhi: Oxford University Press.
- Mullik, B.N. 1971. *My Years with Nehru: The Chinese Betrayal*. New Delhi: Allied Publishers.
- North Eastern Region: Vision 2020*, Ministry of Development of North Eastern Region, May 2008
- Sikkim Development Report*, Government of India, Planning Commission, 2008
- Singh, K.S. (General Editor). 1996. *People of India: Himachal Pradesh*, Vol. 34. Anthropological Survey of India. India: Mahonar.
- Singh, K.S. (General Editor). 1996. *People of India: Sikkim*, Vol. 33. Anthropological Survey of India. India: Mahonar.
- Sinha, A.C. 2008. *Sikkim: Feudal and Democratic*. New Delhi: Indus.
- Tobden, Tashi. (forthcoming). Reflections on History and the Loss of Sikkimese Culture. Paper presented in the Golden Jubilee Conference of the Namgyal Institute of Tibetology, Gangtok, Sikkim in October 2008 on *Buddhist Himalayas: Studies in Religion, History and Culture*.
- Techno-Economic Survey of NEFA*, National Council of Applied Economic Research, New Delhi, 1967.
- Tsering, Nawang. Why Bhoti Should be in Eight Schedule. *Border Affairs*, April-June 2007.

TIBET TODAY: A REGION OF CHINA

SONAM WANGDI
Gangtok

The world today

In order to find a way out of the seemingly perennial Tibetan dilemma, His Holiness The Fourteenth Dalai Lama called a special meeting for the third time, November 17-22, 2008 at Dharamsala, without Himself participating in it, in order to give the delegates absolute freedom to express their opinion without any reservations. The first two such meetings were held in 1951 and 1959. For more than half a century, the Dalai Lama has been trying to find a mutually acceptable solution to the vexed issue. As a septuagenarian, he has, however, justifiably lost hope. He said: "As far as I am concerned, I have given up."¹

Yet the Chinese charge that the Tibetans are 'splittists' is untenable; for they do not want to split the country. All that they want is a meaningful autonomy within China and within the framework of the Chinese constitution. However, this writer does not see any possibility of any fruitful discussion with the Chinese government unless the mindset of the Han leaders undergoes a rational transformation.

Four decades ago, I wrote an article 'Tibet Today: A Nation in Chains' which was published in the Tibetan Review in November 1968. The paper was serialised in *Now!* November 19-21, 2008. The response from the people has encouraged me to pen my thought on the subject in the world of 2008. In 1968, I thought that Tibet might be able to regain her pre-October, 1950 *de facto* independent status in view of the power politics among the major Powers of the world. During the interlude of forty years, there has, however, been a sea change in the international politics, diplomacy and power equations in the comity of nations. The bi-polar interpretation of world politics in terms of a struggle between the United States of America and the Union of Soviet Socialist Republics for world supremacy metamorphosed into a uni-polar planet after the disintegration of the latter on December 25, 1991.

Harold Joseph Laski (1893-1950), the celebrated British political scientist from the London School of Economics and Political Science, had written as early as 1925: "Russia cannot exist as a Communist

¹ *The Statesman*, Siliguri, Nov 17, 2008.

State when she is surrounded by capitalist communities” (1960: 537). Yet during the period, 1968-2008, China steadily advanced towards the status of a major power in the world. The respective Gross Domestic Products in trillion dollars (2002 estimate) of USA, China and Japan are \$10.45, \$5.989 and \$ 3.651.² By the second half of this century, China will be the richest and the most powerful country in history, replacing the United States of America. As early as 1960, Friedmann wrote: “The most important change in the world balance of power results from the emergence of Communist China as the third world Power” (1960: 87-8)—the first two were USA and USSR. As the twentieth century was ushered in, John Milton Hay (1838-1905), who was Secretary of State for the USA from 1898 to 1905, asserted: “The world’s peace rests with China, and whoever understands China, holds the key to world politics during the next five centuries” (Bowles 1955: 69). Very truly did Napoleon Bonaparte (1769-1821) say: “China - there lies a sleeping giant. Let him sleep, for when he wakes he shall shake the world” (*ibid.*: 67). Writing in 1960, Friedmann argued: “After centuries of unchallenged Western supremacy, it is not easy for the people of the West to adjust their thoughts and actions to a world situation in which the balance of world politics would be determined by Asia rather than Europe or even North America” (*ibid.*: 218). During the last two hundred years, the world was dominated first by the British with the help of the British Navy and the British-Indian Army and then the Americans by way of the possession of ‘weapons of mass destruction’. The American domination of the world, represented by the recent swashbuckling occupant of the White House has been resented to such an extent, even by the Americans themselves, that the “approval rating of US President George Bush, on the last leg of his second term, had reached an all-time low in modern opinion polls since 1938, with a record number of Americans saying the country is on the ‘wrong track’.”³ He had to be strictly kept indoors during the election campaign of the new presidential candidate of his Republican party. John McCain had to bear the cross of the existing Republican President Bush and he lost the election to a relatively younger and inexperienced first ‘black’ candidate.

Laski also wrote: “It must be remembered that any great power is a menace to the peace of the world if it has ambitions it cannot fulfill except by the making of war. That was once true of Spain; it was once

² *Competition Refresher Book of the year 2006*, Bright Careers, Delhi, 2005, pages 323, 262 and 282.

³ *The Statesman*, Siliguri, 19 June, 2008, p. 6.

true of France; it is true in our own day of Germany and Japan. But we have to remember that, in the next age, it may be true of the United States if the character of its economic system pushes it, as may well be the case, to imperialism” (1968: 228). The Laskian vista may well be true also of China in less than fifty years.

Consequent upon the meteoric rise of China and its influence in international arena and the concomitant weakening of the American influence, the United Nations Organization had no alternative but to admit the People’s Republic of China as a member and rightfully allot to it permanent seat as one of the Five Big Powers—USA, UK, USSR (Russia since 1991), France and China—in the Security Council in 1971. Prior to this that seat was unjustifiably occupied by the tiny island of Taiwan—with the support of the United States which was hoping that the Government in Taiwan might one day take over mainland China. The year 1972 witnessed the unprecedented visit of US President Richard Milhous Nixon (1913-1994) to China as the communist country had become too important to be ignored any longer in the American national interest. The Sino-American rapprochement led to the gradual withdrawal of covert CIA funding to the Dalai Lama’s office and the Tibetan resistance against the Chinese in Tibet ceased. “The Dalai Lama sent a taped message to the Mustang fighters ordering them to lay down their arms, but rather than surrender, many preferred to die” (French 2003: 264).

China’s meteoric rise is not due to, but in spite of, communism. It is due to incandescent patriotism, an uncompromising sense of national unity and determination to surpass the advanced countries in everything - be it in Olympic gold medals, Olympic-sized airports and other modern infrastructure, the health profile of its citizens or in any other parameter of development. It is this spirit of nationalism, among all the age-groups of the population, that is feeding China’s determination to become the greatest nation on the planet.⁴

Moreover, the founding fathers of the Chinese republic were dedicated and devoted men and women. Bowles (1955: 105) writes:

The administration of the country is carried on by men who live under strict discipline, whether civilian or military. Many are paid no salaries, but are given only board and lodging, a bare minimum of clothing, some cigarettes, free education for their children and medical attention. Selfless young Chinese have returned from abroad to lead hard and austere lives. ‘The administration is absolutely honest’, writes a

⁴ *The Sunday Express*, New Delhi, August 31, 2008, p.7.

recently expelled Catholic priest who warned against underestimating the strength of the Peking Government. 'I imagine that under the present regime it would be more difficult to buy a Chinese official than an official in the Western countries'. Where salaries are paid, they are extremely low. Mao Tse-tung is said to receive less than the equivalent of \$150 a month. And the earnings of his subordinates are proportionately lower. An awed Indian official once said to me, 'Mao himself has only one suit, and his wife works for a weekly wage'.⁵

Tibet Past and Present

Tibet during the British rule in India enjoyed virtual independence from China. The representative of the Manchu dynasty in Lhasa called the Amban had no effective power. The imperial authority declined to such an extent that in 1856 when Nepal attacked Tibet, China had no role to play. On the conclusion of the war, Nepal and Tibet signed in 1856 a treaty which was not objected to by China. But the British, to keep off other imperial powers—especially the Russian—invented the so-called 'Roman concept' of Chinese suzerainty which worked well in their imperial interests. A year before the fall of the Manchu dynasty, when the Chinese Imperial army entered into Tibet "to facilitate the maintenance of order and for the protection of the existing foreign trade marts" the Dalai Lama fled Lhasa in the night on February 12, 1910.⁶ The Dalai Lama entered into Sikkim through either Jelep La or Nathula—most likely through Jelep La—and "the Maharaj Kumar met him at Rhenock and accompanied His Holiness to Darjeeling and Calcutta."⁷

In October 1911 the revolution against the Ch'ing began; on 12 February 1912 the last Ch'ing emperor abdicated, and, on the 15th Yuan Shih-k'ai was elected president of the new Chinese Republic. Chinese troops in Tibet mutinied and looted Lhasa. In April the Chinese garrison in Lhasa surrendered to the Tibetans but refused to be repatriated to China in the hopes that an expedition from the east would come to their rescue. The Chinese Republican government

⁵ Bowles was US ambassador to India twice in 1951 and 1963. Like John Kenneth Galbraith, he was pro-India. He went even to the extent of defending Prime Minister Indira Gandhi's 'deploring' US bombing of Hanoi and Haiphong which made President Lyndon Baines Johnson 'furious' in July, 1966 (Frank. *Indira*, Harper Collins: London, 2002, p.299).

⁶ *The Times Archives* April 20, 1910 reprinted in *The Times of India*, New Delhi April 26, 1993. Pasted on p.109 of Sir Charles Bell: *Tibet Past and Present*, 1924.

⁷ *The Administration Report of the Sikkim State 1909-10*, Superintendent, Government Printing, India, Calcutta 1920, page 1.

attempted to make the Chinese garrison commander in Lhasa their representative, but this move was resisted by the Tibetans, who demanded the evacuation of all Chinese soldiers and officials from Tibet. Chinese troops were finally removed from Tibet, via India, at the end of 1912 (Smith 1997: 181).

His Holiness remained in Darjeeling till July 1912 when He reentered Tibet “taking up residence at Samdong Monastery near the lake Yamdrok Yumtso until the last of the Chinese garrison could be removed” (*ibid.*). The Chinese were repatriated from Tibet to China through Sikkim and Calcutta sea port.

Owing to the repatriation, from Tibet through Sikkim to China, of 1,263 men, 93 women and 46 children, subjects of China, the Sikkim Darbar was called upon to supply transport, et cetera. This involved heavy expenditure. It was borne by the Government of India.⁸

“In January 1913 the Dalai Lama finally returned to Lhasa. Tibet was free of the Chinese for the first time since 1720.” In January, 1913, the Dalai Lama proclaimed that Tibet was independent and signed a treaty with Mongolia (Bell 124: 304). There were no Chinese in Tibet till October 7, 1950.

On the 7th of October, 1950, forty thousand Chinese soldiers invaded Kham in Eastern Tibet (French 2003: 259). Exactly one month after the invasion, Sardar Vallabhai Patel (1875-1950), Deputy Prime Minister and Home Minister of India, wrote a prophetic letter to the Prime Minister Nehru on November 7, 1950 stating that

very soon they [the Chinese] will disown all the stipulations which Tibet has entered into with us in the past. That throws into the melting pot a frontier and commercial settlements with Tibet on which we have been functioning and acting during the last half a century. The undefined state of the frontier and the existence on our side of a population with its affinities to the Tibetans or Chinese have all the elements of the potential trouble between China and ourselves (Arpi 2004: 225).

The Sardar proposed that India should send a token Indian force to help the Tibetans in resisting the Chinese invaders (Thomas 1960: 210). His proposal, however, fell through.

In the fifties, India had to withdraw all the rights it had acquired since 1904 as forewarned by Sardar Patel. The situation on the peaceful pre-independence Sino-Indian border—as peaceful as the US-Canadian

⁸ The Administration Report of the Sikkim State 1918-19, p 3-4.

border—changed overnight and became volatile for the first time in the history of the two biggest Asian countries.

It was a grievous mistake committed by the first Prime Minister of India who deviated from the time-honoured policy of keeping China out of Tibet by gainsaying Chinese sovereignty over Tibet. Once India accepted Tibet as “the Tibet region of China” for the first time in 1954 in the treaty between India and China, it became difficult to controvert the Chinese claim over territories which had been once a part of Tibet. It is an incontrovertible historical fact that the Himalayan areas—some in India and some outside India—were once a part of Tibet in the past. For instance, there is a place called Sadiya, Assam, India. The original name was Sa-di-ley-ya. ‘Sa’ means land; ‘di’ means this; ‘ley’ means from; ‘ya’ means up. The word is Tibetan and Sadiya marked the boundary of Tibet in the south. Moreover, parts of Sikkim, Bhutan and other areas on the Tibetan periphery were once a part of Tibet in the past. It may be recalled that on February 27, 1947, Sikkim had sent to the Government of India a memorandum prepared by Sirdar D K Sen, laying a claim over Darjeeling (Moktan 2004: 113-27). Sikkim was “a former tributary of Tibet” and “originally under Tibetan rule” (Moraes 1966: 191-92). Even as late as 1873, John Ware Edgar, Deputy Commissioner, Darjeeling, during his visit to Kabi, presently Kabi-Tingda in North Sikkim—spelt ‘Kubbi’ by Edgar—found that “the people of this village pay their chief revenue to Thibet, but are bound to do certain services for the Sikhim Rajah, and to supply some food for his household” (Edgar 1969: 55). Sir Charles Bell wrote: Sikkim is “a State of Tibetan origin and originally part of Tibet” (1924: 170). Bell was “Late British Political Representative in Tibet, Bhutan and Sikkim” from 1908 to 1919. He was the greatest authority on the history of the region under his charge. It may be noted that the British protectorate over Sikkim was in accordance with the treaty between the Emperor of China and the Queen of the United Kingdom of Great Britain and Ireland and Empress of India in March 1890.

As stated above, if Tibet belongs to China, then, it follows *ipso facto* that the areas which belong to Tibet also belong to China. Some areas in the North East including part of the Indian State of Arunachal Pradesh were once a part of Tibet in the past which were annexed to the Indian empire by the force of British arms. The Sixth Dalai Lama, Tshangs dbyangs rgya mtsho (1683-1706) was born in Tawang in present day Arunachal Pradesh. The house where His Holiness was born is shown on page 161 of Sonam B Wangyal’s book *Footprints in the Himalayas*, 2006. The McMahon Line “from the east of Bhutan,

along the northern and eastern border of Assam, round to the meeting-place of China, Tibet and the Burmese hinterland” (Bell 1924: 192) was defined in the Simla convention in 1913 between Tibet and British India. The convention was not agreed between China and the British Government. Since the successor Government in India accepted in 1954 that Tibet was a region of China, the McMahon Line demarcating the border between Tibet and India would not be binding on China. However, it is a dangerous doctrine that once an area has been a part of another country, the latter has the right to annex the former at a future date. This argument would allow the British to conquer again its former imperial possessions if it has the desire and military strength.

The main policy of Great Britain in India was to maintain Tibet as a buffer state between China and the British empire and to keep off the Russians from Tibet. The British, being an alien power wanted to ensure that there was absolute peace on the frontier by surrounding its Indian (Burma was a part of India till 1935) possessions by a series of buffer states on the western, northern and north-eastern borders. Thus Iran and Afghanistan in the west were under its sphere of influence; Tibet, Nepal, Sikkim and Bhutan provided the inner and outer bulwark between China and India; Siam or Thailand was the bumper between the British and French empires in the east. Britain had no problem defending India against any naval attack since she was the strongest naval power in the world and the Indian ocean was considered a British lake where no power dared to enter and disturb the British Indian empire. Britain however was not sure of the loyalty of her Indian subjects who could rise in revolt again as in 1857; and an imperial power cannot hold on to its possession if the imperial army had to fight on the border and also to help the Police simultaneously in quelling internal rebellion.

Frank Moraes has written: “Even in the days of British rule in India more than one Chinese spokesman urged the blending of the ‘five colors’, these being China, Tibet, Nepal, Sikkim and Bhutan” (1966: 192). He also writes:

The Chinese irredentist urge is not confined only to Bhutan, Sikkim, Nepal and Ladakh. Over forty years ago the late Sun Yat-Sen cited a long list of so-called lost territories which China would reclaim. ‘We lost,’ he declared, ‘Korea, Formosa and Peng Fu to Japan after the Sino-Japanese War, Annam to France and Burma to Britain. In addition, the Ryukyu Islands, Siam, Borneo, Sarawak, Java, Ceylon, Nepal and Bhutan were once tributary States to China’. Chiang Kai-shek subsequently repeated these claims, and Mao Tse-tung has

reiterated them. Mao in fact traces the beginnings of his political consciousness to his realization of China's territorial losses (1966: 183).

Tibet and China

The entire North Indian cities and important industrial belts are within the devastatingly striking distance from the Tibetan plateau, which is the highest area in the world. During the last two hundred years, the world was dominated by the British and the Americans. "The supremacy of any one nation or civilization", Friedmann writes, "is a passing phenomenon, covering at best a span of a few centuries" (1960: 218). The West has seen that China is going to be the next super power in less than fifty years.

The Dalai Lama was the greatest votary of China hosting Olympic. His Holiness is a man of compassion and there is no place in his heart for hatred. He has been trained from childhood to love all sentient beings. No two countries in history have such an intimate relation as between China and Tibet. In fact the title 'Dalai Lama' was given to the fifth Dalai Lama by a Chinese emperor of Mongolian origin. The Ming emperors and the Dalai Lama had mutual interests; the former wanted the influence of the Lama to rein in his Buddhists subjects and the latter to secure himself against any possible challenge to his authority.

The possession of India made Britain the greatest and mightiest power in history. The possession of Tibet by China will facilitate it towards its goal of the sole super power. The European countries and USA have rightly condemned the Chinese action in Tibet as a violation of human rights. But if we consider European peoples' actions in the present day United States, Mexico, Australia, Brazil, etc., it will be a pathetic story. For instance, the so-called Red Indians were ruthlessly wiped out in the American continent. "By destroying the buffalo herds, the whites were destroying the Indians' main source of food and supplies" (Newmann 2004: 8). On October 2, 1932, Jawaharlal Nehru wrote to his daughter: The Red Indians "were practically exterminated, and most of them died off under the new conditions. There are not many left today of these people who once inhabited a whole continent" (1949: 356). In modern parlance, the crime of genocide was committed in the Australian, North and South American continents in the 18th and 19th centuries. It is unfortunate that the original Americans are not called Americans; they are called 'Indians' and the settlers are called 'Americans'. Similarly the native people in present day Mexico were wiped out. The same is the story in Australia and South America.

However I do not intend to give the impression that the Chinese brutality should be condoned.

For their present plight, the Tibetans themselves are responsible to a considerable extent. The British Government in India wanted to open up Tibet for trade; and several attempts were made through 'the suzerain power', China, but failed. Then Lord Curzon, Viceroy of India, who rightly understood that 'the Chinese suzerainty' was a 'constitutional fiction' wrote to the Dalai Lama; but the letters were returned unopened. If Tibet had responded to the British overtures, the whole of Tibet perhaps would have been independent. Even if the entire Tibet could not have been independent, it can be said with certainty that Outer Tibet would have been independent in the same way as Outer Mongolia, which is much nearer to Beijing than Tibet, is independent today. At the time of the collapse of the Manchu empire, both Tibet and Mongolia were constituent units of China. Both had Outer and Inner areas, called Outer and Inner Tibet and Outer and Inner Mongolia. Inner Mongolia is still a part of China. With the help of the two-year old USSR, the Mongolian People's Republic was proclaimed in 1924. In 1945, another Sino-Russian Treaty was concluded according to which the Chiang Kai-shek government of Nationalist China recognized the complete independence of Outer Mongolia. The action of the British empire in India would have similarly led to the independence of Outer Tibet. The British empire wanted an independent Outer Tibet, not because of love for Tibet; but because it did not want China on its threshold. A quarrelsome and powerful neighbor is a perpetual headache. Despite repeated attempts from the British-Indian Government, Tibet kept aloof on the grounds that the British "were harboring ulterior designs on their country and their religion" (Bell 1924: 62). But the British policy in India was to annex only those territories which were fertile and rich in mineral resources and leave the rest under the largely autonomous Princely States which were in their largest number in the semi-desert areas of Rajputana (now Rajasthan and the Hyderabad region). Britain's interest in Tibet was to gain access to the vast Chinese market and to maintain the buffer zone to prevent any possible collision between the two empires. "In 1910, the Tibetan Government would have welcomed a British Protectorate," the Tibetan Ministers remarked: "The Indian States were in an ideal position, for each was safe from external aggression and free from interference as regards its internal administration. They sighed as they added, 'That is how we should like Tibet to be'" (Bell 1924: 246-7). Bell continues: "But it was recognized on our side from the first that this

would have devolved far too heavy a burden upon us, the responsibility of protecting the distant and difficult expanses of Tibet” (*ibid.*: 247).

“The first communication of the Government of independent India to the Foreign Office of the Tibetan Government was to request the latter to ratify the Simla Convention.” Unfortunately, “Lhasa refused to ratify the Simla Convention until territories such as Darjeeling and Kalimpong were returned” (Apri 2004: 11). The Simla Convention was finally ratified by the Governments of Tibet and India in 1948 (*ibid.*: 123).

It was not in the interest of Tibet to refuse to recognize the independent government of India as “the legal inheritor of the treaties, rights and obligations of British India.” By the time it was too late, Tibet recognized the Indian Government as the successor to the British-Indian government on 11 June, 1948 (*ibid.*: 12). Moreover, Nehru was unhappy with the Tibetan view on ‘lost territories’. These factors contributed to Nehru’s policy towards Tibet.

The possibility of militarily defending Tibet was formally discussed at that time, by the US and British governments. The conclusion was that it was not easy to help the Tibetans as the terrain was not favorable and in any case it was up to the Indian Government to decide since the arms or equipment would have to transit through India (*ibid.*: 19ff).

The Government of India made it clear that “it cannot, however, render active military assistance in form of dispatch of troops to Lhasa” (*ibid.*: 19ff). If India had taken the required initiative, it was likely that the Western countries would have helped Tibet in consonance with their policy of containment of communism anywhere and everywhere, as incorporated in the Truman Doctrine in the name of the US President Harry S Truman on March 12, 1947.

The Treaty between the Republic of India and the People’s Republic of China on Trade and Intercourse between ‘the Tibet region of China’ and India was signed on 29th April, 1954 at the Ministry of Foreign Affairs in Beijing by the Indian Ambassador N Raghavan and Chang Han-fu, the Chinese Deputy Foreign Minister. Normally, a treaty is signed between two countries without mentioning any particular area within the country. But the Chinese diplomacy succeeded in mentioning Tibet as ‘the Tibet region of China’. Never before was Tibet referred to as ‘the Tibet region of China’. Thus, Tibet was sacrificed at the altar of Sino-Indian friendship. The treaty was then ratified on 4 June 1954 (*ibid.*: 211).

Subsequent events demonstrated that the treaty was the source of perennial border problems. The Chinese government complained on

29th June 1954—only after 25 days of the ratification of the treaty—that Indian troops with rifles had crossed into the Tibet region of China and intruded into Wu-je area. It appears that India negotiated the 1954 Treaty out of compulsion. The Prime minister, J.L. Nehru said: “We must give up these facilities such as telegraph lines; if we do not give them up voluntarily, then we shall be forced to give them up. The fact is that if we did not like to give up those things, we would have been forced to give them up. We must accept this fact” (Prime Minister’s speech in the Lok Sabha, 18 May, 1954 (Chakravarty 1961: 60).

But if China is aspiring to be the super power it should behave responsibly and allow full autonomy to the Tibetans without compromising its national security and unity. It should withdraw the People’s Liberation Army from Tibet and the Sino-Indian international border, keeping only border check posts to prevent illegal ingress or egress into China

Tibet as a Region of China

Tibet—a comparatively vast area—is the roof of the world and its possession gives China geopolitical advantage in its cherished aim of dominating the Asian continent and ultimately the world. The might of the erstwhile British empire, as stated above, was founded upon the resources and strategic importance of India. Britain was relegated to a minor power after the loss of the Indian empire. Similarly, Tibet as a part of China will give the latter strategic importance and security. If Tibet either falls into the hand of or becomes an ally of, another major power, the security of China will be gravely threatened.

The importance of the Tibet region also lies in the fact that most of the major and minor rivers in China and Southeast Asia including the Indian sub-continent originate there. For instances, the 2,897 kilometre long Indus river of India and Pakistan, which is one of the largest irrigation systems in the world ; the 2,704 kilometre long Brahmaputra which is an important waterway of southern Asia; and the 2,400-kilometre long Salween, the major river of Southeast Asia and the longest in Myanmar. Other major rivers—Mekong and Yangtze—flow through Tibet.

Only in the event of China degenerating into a condition similar to the one obtaining in the first decade of the last century can Tibet hope to regain its de facto or full independence—a possibility which does not seem likely.

In the interest of the Tibetans themselves, therefore, they should cooperate with the Chinese and convince them that the meaningful

autonomy will not in any way harm the Chinese national interest. The Dalai Lama said his faith in the Chinese officials was becoming “thinner and thinner” while his faith in the Chinese people was “growing stronger and stronger” and he advised the Tibetans to “develop good relations” with the Han Chinese people.⁹ The advice of the Dalai Lama is timely. The Tibetans should try to win the hearts of the Hans who should exert pressure on their government to grant meaningful autonomy to Tibet. The Dalai Lama also rightly pointed out that people showing concern and sympathy for the Tibetan cause should not be seen as “pro-Tibetan” but as “advocates of justice” (*ibid.*). China, the future super power, should act magnanimously and give absolute autonomy to Tibet retaining only external affairs, defense, communication, currency, and citizenship. The Central Government should not interfere with the Tibetan social, religious and customary practices, unless they hinder the political, civil and human rights of the Tibetans. All civilian posts in Tibet should be manned by the Tibetans with the Dalai Lama as the spiritual and temporal Head of the government of the Tibet region of China. Their peaceful coexistence will be in the interest of both—especially the Tibetans. A happy Tibet will strengthen the hand of China in its bid towards gaining the super power status. With some exceptions, history has been a witness to the coexistence of a theocratic Tibet under the thirteen incarnations of the Dalai Lama and the imperial China. Let the millennium herald the peaceful and exemplary coexistence between a theist Tibet and an atheist China within the Chinese constitutional framework.

REFERENCES

- The Administration Report of the Sikkim State 1909-10*. Superintendent, Government Printing, India, Calcutta 1920.
- The Administration Report of the Sikkim State 1918-19*. Superintendent, Government Printing, India, Calcutta 1920.
- Arpi, C. 2004. *Born in Sin: The Panchsheel Agreement: The Sacrifice of Tibet*. New Delhi: Mittal.
- Bell, C. 1924. *Tibet Past and Present*. Oxford: Clarendon.
- Bowles, C. 1955. *The New Dimensions of Peace*. Montreal, Canada.
- Chakravarti, P.C. 1961. *India-China Relations*. Calcutta: Firma K L Mukhopadhyay.
- Competition Refresher Book of the year 2006*. 2005. Delhi: Bright Careers.
- Edgar, J.W. 1969 [1874]. *Sikkim and the Tibetan Frontier, in October, November, and December, 1873*. Bibliotheca Himalayica Series 1 vol 2. New Delhi: Manjushri.

⁹ *The Statesman, Siliguri*, Monday, Nov 24, 2008.

- French P. 2003. *Tibet Tibet*. India: HarperCollins.
- Friedmann, W. 1960. *An Introduction to World Politics*. New York: Macmillan.
- Laski, H.J. 1960. *A Grammar of Politics*. London: Allen & Unwin.
- Laski, H.J. 1968. *Reflections on the Revolution of our Time*. New York: Frank Cass.
- Moktan, R. 2004. *Sikkim Darjeeling Compendium of Documents*.
- Moraes, F. 1966. *The Revolt in Tibet*. Delhi: Sterling.
- Nehru, J.L. *Glimpses of World History*. 1949. London: Lindsay Drummond.
- Newmann, Ben V. 2004. *Selected Classic Essays*. Delhi: Rohan.
- Smith, W.W. Jr. 1997 [1996]. *Tibetan Nation: A History of Tibetan Nationalism and Sino Tibetan Relations*. India: HarperCollins.
- Thomas Jr. L. 1960. *The Silent War in Tibet*. London: Secker & Warburg.

LÁSO MÚNG SUNG:
LEPCHA ORAL TRADITION AS A REFLEXION OF CULTURE

JENNY BENTLEY¹
University of Zurich

In this article a specific narrative of Lepcha oral tradition will be discussed and its various branches and localised version unravelled. I will show how it reflects, explains, and discusses main concepts of Lepcha culture and belief. Oral tradition can be understood as a “culture’s reflexion on itself” (Blackburn 2008: 4). It is insider’s fiction and therefore an insider’s way of preserving, creating, and reinforcing local concepts as well as social, religious, and cultural values. Narrations are passed down over time, but never static as they are shaped by changing local surroundings, social rules, and cultural concepts. Oral tradition therefore exists in reciprocity – it reflects culture and is formed by the same (Blackburn 2008: 4-6).

The Mútunci róngkup rumkup (ཅུམུམུམ་རུམ་རུམ་རུམ་ཅུམུམ་)²³ or Lepcha, a Sino-Tibetan ethnic group living in the southern hills of the Himalayas in

¹ This article would not have been possible without the help and patience of many people in Sikkim and Kalimpong. I would like to thank the various *bongthings*, *mun* and elders who spent many hours introducing me to Lepcha oral tradition and let me observe the ritual performances; Kachyo Lepcha from Lingthem who has been my assistant and friend over the past year, introduced me to Lepcha people and language, and enriched my work with discussions, and Azuk Tamsangmo from Kalimpong who has been a constant source of inspiration and guidance.

² In this article two Lepcha dictionaries are used (K.P. Tamsang 1980, N. T. Tamsang 2005). If there is no reference given, then the Lepcha word is based on K.P. Tamsang’s dictionary. When Norbu Tshering Tamsang’s dictionary is used, the reference will be given. When the two dictionaries differ in translation, it will be indicated.

³ The Lepcha word *mútunci* describes the concept of mother nature: “the universe, with all its phenomena, whom the Lepchas respect as the mother of all mothers” (K.P. Tamsang 1980: 662). In this context *róng* is usually translated with the word ‘Lepcha’ and treated as the short form of the endonym of the ethnic group. It has many different meanings such as ‘to wait’, ‘horn’, ‘peak’, ‘a species of rattan’, ‘kingly’ or ‘worthy of’. *Kup* means ‘son’, or more gender unspecific ‘child’ and *rum* is Lepcha for ‘deity’. Freely translated the name would mean ‘children of mother nature and god’, or even ‘the kingly children of mother nature and god’. This translation would emphasise a feeling of superiority as K.P. Tamsang does (K.P. Tamsang 1980: 773). It could also be translated as ‘children worthy of mother nature and god’.

Nepal, India (Sikkim, Darjeeling District of West Bengal), and Bhutan, have a rich and diverse oral tradition which is sadly being told less and less. Several myths, legends, songs, and parables have been collected in various publications in the past and present. Today some elders, interested younger members of the community, and ritual specialists still have knowledge of Lepcha oral tradition. In Lepcha the word *lúngten sung* (ལུང་ཏེན་སུང་) is used for a vast amount of myths arranged around the creation story. *Lúngten* can be translated as ‘tradition’ and describes the activity of handing down statements, beliefs, legends, or customs from generation to generation. *Sung* is the Lepcha word for ‘story’ or ‘narrative’. It can be used for fiction or real life narratives, for myths, legends, or historical epics. The concept *lúngten sung* is not used for the entire corpus of Lepcha oral tradition but for mythological stories explaining the origin of the world, humans, animal characteristics, and other important elements of Lepcha culture. Arthur Foning, a Lepcha author, describes the meaning of *lúngten sung* for his personal life and for the Lepcha community as follows:

My grandfather, my father, and uncles all used to keep us youngsters spell-bound with the wonderful narrations of events, and stories which were most absorbing. Occasionally, they also used to tell us our Lungten Sung, or stories from our ancient mythology, legends, and other folk-lore which included stories of animals, birds, insects and the like, and fairy tails.

Among other stories, Lungten Sung takes up a place exclusively its own. Looking, deeper, I now find that these absorbing stories acted as the vehicle and the medium to fashion and shape the very behaviour and attitude of our Rong Tribal society as a whole. In fact, they were a veritable treasure house of our Lepcha culture (Foning 1987: 87).

The *lúngten sung* of the Lepcha can be described as a set of stories vibrant with local versions and different narrative strands that all intertwine to a vehicle of transmitting culture and tradition. When recounting, at every crossroad the storyteller can take a different turn depending on which aspect of Lepcha culture he or she wants to highlight. They also have to choose a starting and a finishing point in a seemingly never-ending web of stories. Often enough the narration will be influenced and spiced up with local specialities relating to stones, sacred groves, or other landscape markers to be found just outside the front door.

The oral tradition discussed in this article is the story of *Láso múng* (ལཱ་སུང་མུང་), one of the most ferocious demons in Lepcha mythology. Some narrators describe him as a king who rules over all other evil

spirits and in Dzongu the Lepcha ritual specialists (*bóngthíngs*)⁴ tend to compare *Láso múnng* with a bird (see also Gorer 1996: 55; Kotturan 1989). One informant describes the demon as a birdlike black creature with wings and eyes of fire (Tempa Lepcha, Solophok, July 2009). In Lepcha *láso* (ལ་སོ) is a verb and means ‘to change’, ‘to alter appearance’; *múnng* (མུན) is translated as ‘demon’, ‘evil spirit’. Therefore, *Láso múnng* is a demon that alters its appearance.⁵ The narrative of *Láso múnng* is well known in Lepcha areas today and also seems to have been in the past then Gorer who did his fieldwork in Lingthem Dzongu, in 1937, describes it as an “oft-repeated etymological myth” (Gorer 1996: 55). The main narrative strand in all versions discussed is that this vicious demon terrorises and slaughters Lepcha people, until with a lot of effort and the help of supernatural beings the Lepcha fight and manage to kill it.

The versions of the *Láso múnng* narrative presented in this article have been told and written down at different times in various localities in Sikkim and the Darjeeling District with varying objectives, intentions, purposes, and methods. I recorded and translated the story from senior ritual specialists, villagers, and members of the Lepcha associations in the Lepcha reserve of Dzongu in North, South and West Sikkim and Kalimpong in 2006, 2008 and 2009. Other versions of the story were written in local newspapers on the occasion of Lepcha New Year by members of the Sikkim Lepcha Association.⁶ Some are published by Lepcha writers and scholars from Kalimpong such as K.P. Tamsang, Lyangsang Tamsang, Sonam Tshering Tamsang, P.T.

⁴ In the Lepcha community there are two different types of ritual specialists, the *bóngthíng* and the *mun*. In Dzongu and some parts of East Sikkim the *bóngthíng* are called *padhim* and all three words are often used interchangeably. A *bóngthíng* usually performs the clan, house, healing, and community rituals. He uses plants and flowers in his rituals. The *mun* can also do these ceremonies, but she is mainly a medium, she gets possessed by spirits of ancestors or deities and in this way makes prophesies. Further only a *mun* can guide the dead spirit to the after world. Usually *mun* are women, but men can also be, whereas only men can become *bóngthíng*. Still a lot more research has to be done on this topic (see works of Siiger, Jest, Nebesky-Wojkowitz).

⁵ De Beauvoir Stocks calls *Láso múnng* the cloud demon (Beauvoir Stocks 1975: 28), I am not sure why this name is used, none of the *bóngthíng*, village elders, members of Lepcha associations I have talked to, nor any other publication mention this name for the evil spirit.

⁶ Karma Loday Lepcha 1999: 3; Tom Tshering Lepcha 2003: 3; Tom Tshering Lepcha 2004: 3.

Simick, and Arthur Foning⁷ while others were collected by anthropologists who have previously worked among the Lepcha such as de Beauvoir Stocks, Gorer, Siiger, Jest, Chakrabarty, Kotturan.⁸ One version reproduced is an English translation of a Lepcha book that was written in 1886 in the region of Kalimpong. This is the oldest written reference to the *Láso múng* story found so far. A different name (*Jhylum pahu pani*)⁹ is used for the evil spirit but the narrative is comparably similar.¹⁰ The oldest versions written in English language were collected by de Beauvoir Stocks in Lang-dang in North Sikkim and Pakyong in East Sikkim, close to Gangtok, in 1925. Gorer and Siiger mainly did their research in Dzongu, in the villages of Lingthem and Tingvong. Gorer conducted his fieldwork in 1937 and Siiger ten years later in 1949-50. Siiger has published two versions of the *Láso múng* story in his ethnography published in 1967, one from the villager of Tingvong, and another one from an informant from Kalimpong, and another summary in an article from 1972. Jest collected his material in 1953 in Tanyang, a village near Kalimpong.

STORY OF ORIGIN: PLACING *LÁSO MÚNG* IN A MYTHOLOGICAL CONTEXT

Where does a narrative start? In Lepcha mythology all *lúngten sung* is a part of the story of origin. Therefore, some storytellers when recounting the myth of *Láso múng* start with the creation of the world, mankind, and the Lepcha people. In this article I will not discuss the creation myth in its detail, but I would like to give a short summary and show where the storytellers branch off into the story of *Láso múng*. After *Ítbú*

⁷ Foning 1987: 127-129; Simick 2001; K.P. Tamsang 1998: 5, 38-40, 44, 64; Lyangsong Tamsang 2008: 5-8, 9,10, 14, 15; Sonam Tshering Tamsang 1999: 29-35.

⁸ Beauvoir Stocks 1975: 28, 29, 176; Gorer 1996: 55; Siiger 1967: 112-114, 175; Siiger 1972: 241; Jest 1960: 126, 127; Chakrabarty 1985: 215, 216; Kotturan 1989: 20-28, 58.

⁹ *Jhylum pahu pani* is described as the ultimate evil spirit. When *Ítbú debú rum* created the humans, they could not survive because this malevolent being with powers as strong as the creator god was killing all the human beings. For this reason the creator god bestowed the first Lepcha ritual specialists with supernatural powers. They succeeded in finding ways to appease the evil spirits (P.T. Simick, Ngasey, August 2009).

¹⁰ Nyu-lik Nyusong Translation 1992. The original Lepcha book was written in 1886 by Moong Shyel Simick-mu from Ngasey village near Kalimpong. It was then copied again by his decendent Passang Simick in 1961. This copy is the book translated by the Indigenous Lepcha Association of Kalimpong.

debú rum¹¹ made water, earth, sky, clouds, and so forth, she¹² creates Fadróng thing (ཁ་ལྷ་མོ་མེད་མོ་)¹³ and Nazóng nyú (འཇམ་མཉམ་པ་མེད་མོ་) from the snow of the Mount Kangchendzonga. They are the progenitors of the Lepcha people, however not humans but rather humanlike supernatural beings. Fadróng thing and Nazóng nyú are sent down to the world and supposed to live as brother and sister. The couple violates the incest taboo, Nazóng nyú gets pregnant several times and the babies born are thrown away. Often no motivation for this act of abandoning is given in the story (see Beauvoir Stocks 1975: 20; Gorer 1996: 224; *bóngthíngs* from Dzongu). Some versions mention that the couple is trying to hide their ill doings from Ítbú debú rum (Foning 1987: 89; Kotturan 1989: 19; Gurung/Lama 2004: 119¹⁴; Tom Tshering 2003: 3; Tom Tshering Lepcha 2004: 3; Karma Loday Lepcha 1999: 3); Siiger's reason is more practically orientated: there are too many children to be sustained (Siiger 1975: 299). The number of children they throw away varies, but usually it is seven, sometimes three. Then finally Nazóng nyú feeds a

¹¹ Lepcha deities exist in pairs of male and female. Ítbú debú rum can be described as the creator deity couple. Ítbú (འཇམ་མཉམ་པ་མེད་མོ་) means 'creator' and *debú* (མེད་མོ་) 'destroyer' and *rum* (རུམ་མེད་མོ་) 'god or deity'. Ítbú rum is connotated female as the creator mother so that Debú rum would take over the male part of the divine pair. More research has to be done on the deities and the pantheon in Lepcha religion as many uncertainties remain.

¹² Lepcha as a language is gender neutral so when translating Lepcha stories into English it is sometimes difficult to decide on which gender pronoun to use. Because it is common to mainly name Ítbú rum in the creation story, the female part of the dualism, and translate the name of the deity as creator mother, I will use the pronoun 'she' while narrating the story. The dualism of Ítbú debú rum should be kept in mind.

¹³ Fadróng thing is also called Takbo thing or Tukbo thing. Mirik, *bóngthíng* of Linko, does not approve of the name Fadróng thing, he describes it as an inappropriate nickname for Takbo thing. The Lepcha word *tukbo* (ཐུག་བོ་) means 'protector' so Tukbo/Takbo thing could be translated as 'the lord who protects, or protector'. An influence of Tibetan Buddhism is indicated here as he is then often equated with Tashi thing which is Lepcha for Guru Rinpoche (see Siiger 1972: 258, 259 for discussion on the different names).

¹⁴ In 2004 the Information and Public Relations Department published volumes of Sikkim Study Series, one of which compiles the culture of different ethnic groups in Sikkim (see Gurung/Lama 2004). The part on Lepcha culture was then revised by the Sikkim Lepcha Association (Renjyong Mutanchi Rong Tarzum, RMRT) in 2005 because there were spelling mistakes in Lepcha words and some Lepcha narratives were based on versions found in Kalimpong, but not the variations found in Sikkim. This is especially evident in the story of Lásó múng. In this article the unpublished version revised by the RMRT is used when it differs from the printed version.

child with mother milk and raises it as the first human being.¹⁵ The children neglected by Fadróng thín and Nazóng nyú turn into evil spirits. Taken from here the creation myth can branch of into various storylines – one of them being the tale of Lásó múng.¹⁶ People narrating the creation myth often do not refer to Lásó múng. Sometimes a person will mention the demon's birth by the divine couple when telling the Lásó múng story, but does not do so when recounting the creation myth in a different context. It does not seem relevant or even feasible to mention all the aspects of a narration, but to focus on one main strand of action. Depending on what the storyteller wants to highlight alternative names of demons born are given. Lásó múng is described as the eldest of the children that were deserted and turned into evil spirits. He is the fiercest demon of them all.

The seven sons who had been thrown away into the dense forest had taken the forms of demons and evil spirits. They created lots of trouble to the Lepcha tribe regularly. The eldest had taken the form of a demon. He was the strongest among all brothers and was called *Lasho-Mung-Punu* which literally means *Lasho* the demon King (Gurung/Lama 2004, revised RMRT 2005: 17; see also Foning 1987: 127).

Lásó múng is jealous of the children who were loved by his parents and of all their offspring – the Lepcha people. He convenes his siblings, the other evil spirits, and gets them to join in on a mission to take revenge. This is the reason why he goes out to attack and kill the Lepcha people.

As these demons grew older they felt jealous of their brothers and sisters who had been brought up by their parents instead of cast aside like themselves and began to take revenge by troubling them. They were led by Lasomoong Punu, who was the eldest among the thrown away babies (Karma Loday Lepcha 1999: 3; see also Kotturan 1989: 20; Tom Tshering Lepcha 2004: 3; Tom Tshering Lepcha 2003: 3).

¹⁵ As mentioned, in Lepcha belief supernatural beings often appear in pairs. The same can be said for the first human being. In different versions of the creation story there are either one or two children. The name used is the same, the first human child will be called Ralbusingu (see Gorer 1996: 224; Morris 1938: 63) or it is a twin pair called Ralbu and Singbu. Certain qualities are attached to them. The former is described as a god, the latter as an evil spirit. In this way the creation story explains the dualism between good and evil as well as of life and death (discussed later on in this article) (see Gorer 1996; Morris 1938; Beauvoir Stocks 1975; Charkabarty 1985).

¹⁶ For printed versions of the Lepcha creation story see Beauvoir Stocks 1975: 19ff; Gorer 1996: 223ff; Foning 1987: 88ff.; Kotturan 1989: 17ff.; Siiger 1967: 172ff; Lyangsang Tamsang 2008: 3, 4.

Sometimes, the revenge of the Láso múng is told close to the mythological time when Fadróng thín and Nazóng nyú are still on earth. Láso múng and his entourage go and kill the first human child of Nazóng nyú (*bongthín* of Pentong, December 2008; Tom Tshering Lepcha 2003: 3; Tom Tshering Lepcha 2004: 3; Chakrabarty 1985: 216). With the murder of Ralbu Singbu, the first human twin children, the Láso múng narrative explains the existence of life and death. Ralbu is described as human or even as a god. He is the good side of the child-pair whereas Singbu is considered a *múng* and malevolent. After the evil spirits kill them, Nazóng nyú pleads Ítbú rum for help. She sends down two birds, one with the water of life and one with the water of death.¹⁷ The former is supposed to be given to Ralbu and the latter to Singbu. But the birds confuse the substance and give it the other way round. Since then there is death and birth among human beings while the evil spirits exist eternally – no new ones are born, but none die (Netuk, *bongthín* of Lingthem, April 2006; Siiger 1972: 240).

This storyline remains the exception. In most versions the revenge happens in an undefined time when many Lepcha people have already populated the earth. The Lepcha book *Ahbong chyokung sung* places the event of Láso múng's tortures and the final salvation in a time of agricultural change. It is to be found within the story of an old hunter and his encounter with a supernatural being who gives him the seeds for agriculture. The old hunter starts planting and soon other Lepcha people follow his lead. Láso múng was in the jungles beforehand but now became more dangerous because he attacked people while working in their fields. Therefore, they decided to kill him (Simick 2001: 15, 16).

PROTAGONISTS IN THE BATTLE

The supernatural protagonists who take on a prominent role in fighting and defeating Láso múng vary depending on the narrator. A number of sources do not name a personified individual, but just call it the struggle of the Lepcha people against the evil spirit (Foning 1987: 127; Beauvoir Stocks 1975: 28, 29; Siiger 1967: 113; Simick 2001: 18). Three different supernatural beings or deities (Jor búngthín, Támsáng thín, Kumyâ kumshi rum) are mentioned in different regions of Sikkim and Kalimpong.

In versions printed or narrated by members of the Sikkim Lepcha Association and also found in the East, South and West districts of

¹⁷ In some versions it is also just called the god water and the devil water.

Sikkim as well as the Darjeeling District, Jor bǒngthǐng (ཇོར་བོང་ཐིང་) is sent to earth by the creator deity Ítbú debú rum to free the Lepcha people from Lásó múng.

The Lepchas had no alternative but to pray and seek help from Itbu Rum to save themselves from the demon. It is believed that Itbu Rum on hearing the prayers, sent Jor Bongthing bestowed with full of supernatural power to Ney Mayel Lyang (Tom Tshering Lepcha 2004: 3; see also Tom Tshering Lepcha 2003: 3; Karma Loday Lepcha 1999: 3; T.T. Lepcha, President Literarcy Association, Gangtok, January 2009; Tempa Lepcha, Solophok, July 2009; Gurung/Lama 2004, revised RMRT 2005: 18).¹⁸

Jor bǒngthǐng is described as one of the most powerful ritual specialists (*bǒngthǐng*) of the Lepcha. He is the first to be bestowed with the supernatural powers of appeasing evil spirits by Ítbú rum. But not much else is known or told about this figure. None of the older sources such as Siiger, Gorer or de Beauvoir Stocks talk about Jor bǒngthǐng. In Dzongu, where Gorer and Siiger both did their research, Jor bǒngthǐng does not seem to be known or at least does not play a part in this narrative. One of the senior ritual specialists, Mirik, *bongthǐng* of Linko in Tingvong, vehemently tells me that there is no such *bǒngthǐng*. A Lepcha book on the first Lepcha *mun*, Nyolík nyosong, written in 1886 in the region of Kalimpong, also mentions Jor bǒngthǐng as her companion in killing the most vicious demon:

This story begins with the creation of the universe, its humans, animals, beasts and birds. How because of the demon, Jhylum-Pahu Pani, that is, the embodiment of evil, disasters and death occurred all over the earth and so, the sending down by the gods, the godlike Bongthing Nyu-Lik Nyusung, with his companion, Jhor Bongthing, to subdue these evils (Nyu-Lik Nyusong, Translation 1992: 1).

Here Jor bǒngthǐng is portrayed as a deity who was bestowed with the powers of a *bǒngthǐng* when the god Lagyek “caught hold of the leaves of the broom bush and other kinds of weeds and leaves in the forests, and, looking hither and thither, started to shake and became very well known as the wisest who could exorcise the evils of mankind, the

¹⁸ The published version of the Lásó múng story in the Sikkim Study Series does not mention Jor bǒngthǐng (Gurung/Lama 2004: 117-120) but names Támsáng thǐng as the main protagonist. This part has been completely rewritten by the Sikkim Lepcha Association to highlight the version more common in Sikkim. Támsáng thǐng is now merely referred to in one sentence (Gurung/Lama 2004, revised RMRT 2005: 19).

animals and living creatures on this earth” (Nyu-Lik Nyusong, Translation 1992: 8).

In Kalimpong usually a different supernatural being is recorded as protagonist battling Láso múng:

When the Lepchas were suffering under the severe oppression of the demon king, Laso Moong Pano, they prayed to God to save them from the demon king. God felt pity on the Lepchas and as such He again came down on the summit of Pundim and created Tamsangthing which means ‘the saviour’ from the pure, virgin snows of Pundim peak and sent him down to Mayel Lyang to kill the demon king and his followers and deliver the Lepchas from misery. Before sending him down to Mayel Lyang, God said to him, ‘you are my best creation and therefore my most beloved one’ and then God bestowed upon him with supernatural powers to subdue the demons (K.P. Tamsang 1998: 64; see also Lyangsong Tamsang 2008: 6).

Támsáng thing (ཨ་ལཱ་ལོ་ལྷ་མོ་) is a supernatural being created from the snows of Mount Pandim in Sikkim by Ítbú debú rum to save the Lepcha people from Láso múng. The origin of his name is not clear. In a footnote Lyangsong Tamsang clarifies that Támsáng thing is not connected directly or indirectly with the Lepcha clan Támsángmo or Támsáng/Dámsáng lyáng (Lyangsong Tamsang 2008: 10). Támsáng/Dámsáng lyáng is the Lepcha name for the area around Kalimpong. It is interesting to note that this supernatural being is only known and commonly referred to in exactly this region. Some members of the Lepcha community in Kalimpong also tell the Láso múng story with Jor bóngthing as a protagonist. In other Lepcha areas Támsáng thing is not mentioned at all. Some narrators name both protagonists. In these versions Támsáng thing does not fight Láso múng himself, but creates the first Lepcha *bóngthing* (Jor bóngthing) and the first Lepcha *mun* (Nyolík nyosong) to fight or assist the Lepcha people in fighting the demon:

Lepcha traditions says that when Lord Tamsangthing arrived at Tarkaol Tam-E-Tam from Pundim Cho (Mt. Pandim) to deliver the Lepchas from the clutches of the demon king, Laso Moong Pano, what he found was that the Lepchas were so much degraded by the excessive harassment of the demons, particularly of Laso Mung Pano, and not to speak of fighting with them. So in order to rejuvenate their morale, Lord Tamsangthing wished to give the supernatural powers to a chaste man and chaste woman and made them bring back the lost morale philosophy of the Lepchas. Thus the first consecrated Boongthing was Thikoong Azoar Boongthing and the first consecrated Mun was

Nyookoong Nyoolik Mun (K.P. Tamsang 1998: 44; see also Lyangsong Tamsang 2008: 6).

Sonam Tshering Tamsang, a renowned Lepcha poet and scholar from Kalimpong, wrote a short text in Lepcha language on Nyolík nyosong and Jor bǒngthín in the *King Gaeboo Achyok Birth Anniversary* of 1999 which was translated by Lyangsong Tamsang, President of the Indigenous Lepcha Tribal Association of Kalimpong. Here it is described how Támsáng thín gives the divine powers to a selected human from Dzongu in North Sikkim:

Tamsang Thing felt that Nyolik-Nyosong Mun alone was not sufficient and effective to fight back the evil elements in the future and restore peace and tranquillity in the Lepcha land, therefore, he found a young, pure Lepcha lad living in a cave named ‘Dub-Dr’, above ‘Puntaong’, Zaongu. Tamsang Thing, again, consecrated this young man with three shoots from ‘Pashyor’, elephant grass, and gave him supernatural powers at a lake named ‘Azaor’ or ‘Da Yaong Chaok’, Saa Kyung, upper Zaongu, hence, his name ‘Azaor Boongthing’. In Lepcha ‘azoar’ means crystal clear (Sonam Tshering Tamsang, translation by Lyangsong Tamsang 1999: 35).

In the Kalimpong versions the Lepcha ritual specialists are not given their powers by Ítbú debú rum itself, but Támsáng thín is responsible for this task. He takes in the place between the creator god and the first Lepcha ritual specialists.

Almost all the versions collected in Dzongu from senior ritual specialists in 2006, 2008 and 2009 name Kumshi rum or Kумыâ kumshi rum (ཨྲཱེ ཨྲཱེ རྩྭ) as the main god or gods chasing Láso múng. Netuk, the *bǒngthín* from Lingthem village, describes it as follows:

All the gods of knowledge (Kумыâ kumshi rum) are meeting to discuss how to destroy Láso múng. [...] All this time the Kумыâ kumshi rum were chasing Láso múng. [...] And still the Kумыâ kumshi rum were behind Láso múng and thinking about how to kill him. [...] (Netuk, *bǒngthín* of Lingthem, October 2008).

In Gorer’s version of the story that was collected in the late 1930s and most likely also from villagers of Lingthem the same gods also play an important role, but in the end they seek for a supernatural being to chase and kill the demon. The names of the gods vary slightly, but this is almost certainly a problem of transcription from Lepcha language.

This devil was a man-eater; he used to capture people all through the neighbourhood and take them away to Tibet where he would kill and eat them. Therefore the Gods Kansi *thing* (lord), Kom-yo *thing* and

Saktsum *thing*¹⁹ consulted together as how they could kill this demon. [...] Then the three gods sent for Rum-nam (a mythological hero) to kill the demon, and wherever the demon went Rum-nam followed (Gorer 1996: 55; see also Kotturan 1989: 58).

Kumyâ kumshi (ཨྲེལྲེལྲེ) is explained as ‘trickery’ or “the use of tricks and habitual deception, has esp. opprobrious connotations” (K.P. Tamsang 1980: 227) in K.P. Tamsang’s Dictionary, *kumyâ* alone means ‘magic’ or ‘cleverness’. In the dictionary published by the Lepcha Language Development Organisation *kumyâ kumshi* (ཨྲེལྲེལྲེ) is translated as ‘knowledge’, which is probably the connotation of the word used in combination with deities (N.T. Tamsang 2005: 40). *Kumyâ kumshi thing* (ཨྲེལྲེལྲེ རྩེ) is “the deity who instituted marriage of human beings” (K.P. Tamsang 1980: 227). In the creation story told in North Sikkim *Kumshi rum* has a prominent position. He is the god who summons all the other gods and deities to meetings when a problem arises such as when *Fadróng thing* and *Nazóng nyú* are found breaking the incest taboo. He is also sent by *Ítbú debú rum* to help the Lepcha when malevolent beings were uncontrolled and killing people. Then he calls together all the gods who make an agreement with the evil spirits. The malevolent beings assent not to harm the Lepcha people as long as they are satisfied with offerings (Pemchedar, *bóngthíng* of Nampatan, April 2006; Gorer 1996: 224). This part of the creation myth of the Lepcha ritual specialists is often told without specifically mentioning *Láso múng*. *Kumshi rum* also gives instructions of where to find important ritual items with powers of healing and appeasing malevolent beings (Netuk, *bóngthíng* of Lingthem, December 2008) and is addressed in the annual ritual the *bóngthíng* holds in honour of his own protector god (Sagi lyót tyet rum fát,²⁰ *Dawa, bóngthíng* of Lingdem, January 2009). This deity is therefore strongly connected with the traditional Lepcha ritual specialists who still today have the duty to protect the Lepcha from evil spirits.

¹⁹ *Sáktsum thing* (ཨྲེལྲེལྲེ) is the god of ambition, “a deity or God who created the thoughts of man and his ability to think” (K.P. Tamsang 1980: 976). This god is not mentioned separately by the ritual specialists in Dzongu today.

²⁰ *Sagi* (ཨྲེལྲེ) ‘power’, *lyót* (ལྲེལྲེ) ‘set free’, *tyet* or *tet* (ཨྲེལྲེ) ‘touch, come into contact with’, *rum* (རྩེ) ‘god’, *fát* (ཨྲེལྲེ) ‘worship’. In this ritual the *bóngthíng* sets his supernatural powers free and then brings them back again on the third day of the ritual.

Even though the protagonists vary in the different local versions of the Láso múng story, they all have characteristics and traits in common. Kumyâ kumshi rum is the main god to call a meeting and make a pact with the evil spirits. In this way he creates the profession and defines the responsibilities of the Lepcha ritual specialists. Támsáng thín is the creator of the first Lepcha *mun* and *bóngthín* whereas Jor bóngthín is considered the first *bóngthín* sent to earth, the first mediator between the Lepcha and the evil spirits. The names of the protagonists differ, but their functions, powers, abilities and positions in Lepcha mythology are similar. They are intermediates between the common people and the evil spirits – supernatural beings specialised in appeasing malevolent spirits.

THE PURSUIT OF LÁSO MÚNG

Resting place of Láso múng: Sanyól kúng (འཇུ) – cú (འུ)

Some of the storytellers, predominantly those from Dzongu²¹, describe the place where Láso múng dwelled before he rampaged through Lepcha land killing people.

Láso múng stayed in Sanyól cú in a big tree called after the mountain, Sanyól kúng. So he lived on top of this tree. From there, from the top of the Sanyól cú, he could see the entire world, also Máyel lyáng, he observed and killed human lives (Netuk, *bóngthín* of Lingthem, October 2008; same also from Dichen, *bóngthín* of Sapho; Dawa, *bóngthín* of Lingdem, and *bóngthín* of Pentong; Siiger 1967: 113).

When describing the dwelling place of Láso múng, Sanyól kúng (འཇུའུའུ) and Sanyól cú (འཇུའུ) are often named simultaneously. The evil spirit rests in the top of a tree which is mythologically completely intertwined with the mountain. Gorer's version of the Láso múng story shows this entanglement. At first the tree is not mentioned:

On any clear day there is visible from Lingthem a large gendarme of black rock rising from the mountain Siniolchi, or, as it is called in Lepcha, Sanyol-koong. On the gendarme there lived once upon a time a devil called Lasso-fo *moong* (Lasso bird devil) (Gorer 1996: 55).

The habitat of the demon is described as a gendarme or a hillock. This is interesting because the Lepcha word *kung* (འཇུ), pronounced slightly

²¹ In Kalimpong PT Simick (Ngasey, August 2009), Beauvoir Stocks 1975, Foning 1987 and the Lepcha book *Ahbong Chyo Kung Sung* (Simick 2001) also mention Láso múng dwelling in the Sanyól kúng.

differently, actually means ‘small hill’. But just a few sentences later the gods try and cut down a tree. Gorer himself puts a footnote mentioning a “verbal confusion” (Gorer 1996: 55) between the meanings of the Lepcha word *kung* or *kúng*. This cannot be the only explanation as the tree takes on an important role in the narrative and is also used interchangeably with the word *cú* (ꨀ). Siiger’s informant from Tingvong tells him that after the tree vanishes or is cut down, the mountain emerges from this place (Siiger 1967: 175). The way that ‘mountain’, ‘hill’ and ‘tree’ are used to describe the same or a similar seat of evil spirits or gods without any feeling of contradiction suggests that they are related in a mythological way making the words interchangeable in their usage.

Sanyól kúng is a “sago palm tree of the family *Palmaeae*, that grows tall, large, unbranched surmounted by a crown of large, pinnate or palmately cleft leaves” (K.P. Tamsang 1980: 952). It grows frequently in Sikkim and West Bengal and is often cut down because it is said to attract flies (Beauvoir Stocks 1975: 28). The mythological origin of this tree can be found in the creation story. Fadróng thing and Nazóng nyú were sent to earth and spent the first night at a lake (ꨀ; dâ) called Náho náthár dâ (ꨀꨀꨀꨀ ꨀꨀꨀ ꨀ). There they broke the incest taboo.

Nazóng nyú’s hand holds Fadróng thing, but something is hurting Fadróng thing. He says, ‘your bracelet is paining me, please take off your bracelet’. So she takes it off and wants to keep it on her pillow side, but it falls down into the Nahol dâ. Now the bracelet grows into the Sanyól kúng (Namgyal, ex-President of the Mutanchi Lom Aal Shezum (MLAS; a Lepcha association based in Dzongu), Passingdang, January 2009).

Láso múng is hiding in this tree so the various deities or the Lepcha people decide to cut it down and kill the demon. This is not an easy task. The Kumyâ kumshi rum spends all day chopping the tree trunk, but over night the wood regenerates itself. After several failed attempts they look for someone with the special ability to fell down this tree. Patyók bu (ꨀꨀꨀ ꨀ), a caterpillar,²² speaks to the gods:

‘In future you give me the Sungru kúng²³ as a reward for my eating and shelter then I will cut down the Sanyól kúng for you.’ The Kumyâ

²² “the hairy caterpillar the worm like lava of a butterfly or a moth one who preys on others extortioner” (K.P. Tamsang 1980: 590).

²³ Sungru kúng (ꨀꨀꨀꨀꨀꨀ) is “a large tree of middle hill forest but often extending higher than 6,000ft. stem very cylindrical, tall, grows very rapidly, wood

kumshi rum agree and so now today when you cut that tree you will see the caterpillar (Netuk, *bóngthíng* of Lingthem, October 2008).

The gods then cut the tree during the day and at night the caterpillar keeps eating. The senior ritual specialists in Dzongu integrate another episode before the tree falls over. The Kumyâ kumshi rum are suddenly facing a new problem they had not considered beforehand. They have to decide on which direction the huge tree should fall down in. They think of the different possibilities: the tree could fall to the east (Bhutan (ལྷ་ལྷ་ལྷ་, *pro lyáng*), the north (Tibet, ལྷ་ལྷ་ལྷ་, *pât*; China, ལྷ་ལྷ་ལྷ་, *gyánók*), west (Nepal), or south (India). They fear that the huge tree would block the paths, make the trading routes inaccessible, and cut communication with these places.

So then they look at the way to the Kangchendzonga. This way is used by the *bóngthíng* and *mun* to guide the dead souls through the hills.²⁴ After so many people have died, maybe the devils will come out. So it could be best to block this way with the tree. They decide to do that. When the tree falls down, Lásó múng starts flying towards Máyel lyáng or Renjong lyáng²⁵ (Netuk, *bóngthíng* of Lingthem; see also Dichen, *bóngthíng* of Sapho; Siiger 1967: 175; Simick 2001: 17).

The Lepcha book *Ahbong Chyo Kung Sung* states that from this day the Lepcha people could not go and meet the dead souls of their relatives anymore, as the way was blocked (Simick 2001: 17).

Sanyól kúng/cú – and through this element also the story of Lásó múng – is related to a ritual performed at the end of winter in Dzongu. Sátáp rum fát is an offering to Sátáp rum, the god of hailstorms. It is dedicated to Kárnit Kursong dâ (a lake) and the Sanyól cú as the guardians of hailstorm, rain, and wind. In Dzongu it is performed once a year by a *bóngthíng* in nearly every village. In this ritual the god of hail and the guardians are requested not to send destructive storms into

greyish, soft, light. It is called *utis* in Nepali, botanical name: *Alnus nepalensis* D. Don (Betulaceae)” (K.P. Tamsang 1980: 999).

²⁴ In Lepcha this path is called Muk nyám lóm (ལྷ་ལྷ་ལྷ་ ལྷ་ལྷ་ལྷ་), *muk nyám* means “the shade of the dead or departed; the spirits of the dead collectively” (K.P. Tamsang 1980: 656) and *lóm* is “road. n. an open way for passage or travel” (K.P. Tamsang 1980: 865). It can be translated as the way of the spirits of the dead.

²⁵ In a different version told by the same *bóngthíng*, but two years earlier, Lásó múng came into existence because he escaped the spirit world from this path when they chopped down the tree: “So all the gods decided to fell the tree towards Muk nyám lóm. So they did this. While the tree fell towards Muk nyám lóm, from that way Lásó múng came out” (Netuk, *bóngthíng* of Lingthem, April 2006).

their land and to keep the offerings instead.²⁶ Sanyól kúng/cú is where hail and snow comes from. Siiger's informant gives an explanation for the association between Sanyól kúng/cú and the origin of hailstorms and therefore Sátáp rum fát:

While the big tree was on the earth, its flowers were snow and its fruit were hailstones. When it disappeared a big peak appeared on the same spot. It is brown as brass and is called Sa Nyol Kung Bung. Now the snow and the hailstorm came from this peak (Siiger 1967: 175; see also Beauvoir Stocks 1975: 28).

Sanyól kúng with its snow-flowers and hailstone-fruit becomes Sanyól cú making the mountain the guardian of hail and snow (Dichen, *bóngthíng* of Sapho, January 2009). When I ask Namgyal Lepcha, the ex-President of MLAS, to explain the connection, he recounts it as follows:

We perform Sátáp rum fát because during the war between Lásó múng and the Lepcha all the rum declare to cut down the Sanyól kúng. But then they are confused and wonder: 'If we completely cut down this tree, maybe we cannot get the rain, snow, and wind in future. We will have troubles growing plants on our fields.' So that's why they leave a little bit of the tree to grow again. For this reason the Sanyól kúng/ cú is the guardian of Sátáp rum and harvest and rain. [...] When we perform Sátáp rum fat, the Sanyól kúng or the guardians offer rain, wind, and anything suitable for the growing of the crops and vegetables. That's why Sátáp rum fat is always performed in the month of February and March, Lepcha months Thon or Sám²⁷ (Namgyal Lepcha, Passingdang, January 2009).

Two senior *bóngthíngs* of Dzongu (Netuk of Lingthem and Merik of Linko) as well as Siiger's informant describe the mythological place of this ritual is Sanyól bóng on a mountain in front of the Kangchendzonga (Netuk, *bóngthíng* of Lingthem, May 2006; Merik, *bóngthíng* of Linko, May 2006). The Lepcha word *bóng* (འཇ) means 'tree stump'. So, the main place referred to in the ritual is the mythological tree-stump of Sanyól kúng which they say can still be found on Sanyól cú, a mountain in the range of the Kangchendzonga.

²⁶ The general secretary of the Indigenous Lepcha Tribal Association and a *bóngthíng* himself explains that in Kalimpong the offerings to Sátáp rum are given during two other rituals (Lyáng rum fát and Múkjekdíng rum fát). For this reason no separate ritual needs to be performed (P.T. Simick, Ngasey, July 2006).

²⁷ Thon corresponds to the months of March and April, Sám falls in the months of April and May.

Dzongu Version – the destructive flight of a bird

As mentioned in the introduction to this article, elders and ritual specialists in Dzongu also call the evil spirit *fo* (𑄧) which means bird in Lepcha (Gorer 1996: 55; Netuk, *bóngthíng* of Lingthem, August 2006; *bóngthíng* of Pentong, December 2008; Dichen, *bóngthíng* of Sapho, January 2009; Siiger 1967: 175). All senior *bóngthíngs* and elders interviewed in Dzongu as well as Gorer tell the main narrative strand of the *Láso múng* story similarly. After flying away from *Sanyól kúng* the evil spirit rampages through Dzongu killing Lepcha people wherever he goes while the gods are chasing him. It is often described as a flight during which the demon is gliding from one side of the valley to the other.

During his stay in Dzongu Siiger recorded two versions of the *Láso múng* that differ from the others. Therefore, I will relate these before getting into the details of the flight. In one account *Láso múng* gets severely injured when *Sanyól kúng* falls down and then gets killed by the Lepcha people. There is no flight. The second version has some similar elements with the other *Láso múng* stories told in Dzongu, but the flight is completely different:

When the tree disappeared, the bird became startled and flew away. As it was flying through the air, all the wild animals and the birds became startled, too. Among the animals was *tyáng mo*, [...] a huge elephant (one of its tusks is in the house of the priest of *kong chen*). It ran away into the jungle but on the way it had an accident and broke its leg. Then all the other animals gathered to find out what was the cause of their distress. At last they realised that it was the bird, but the bird pointed to the big serpent that had destroyed the tree.

Then the wild birds killed the serpent and took out the bones of its body. These bones they used to restore the leg of the elephant.

Meanwhile the bird was flying in the air being unable to find any place to dwell. One day it discovered the son-in-law of *sím bryong* [...], Saknon Gin. The bird killed the son-in-law and ate the flesh (Siiger 1967: 175).

In all other versions told in Dzongu *Láso múng* flies from the Himalayan mountain range, from *Sanyól cú*, towards the lower valley areas.²⁸ The first place he reaches is Sakyong, the Lepcha village the closest to the uninhabited mountains. Gorer says Sakyong got its name

²⁸ The places change depending on the storyteller, here I have given a version as complete as possible.

because Lásó múng kills Tág kyong ká at this place (Gorer 1996: 55).²⁹ Another source says Lásó múng looks into every corner, takes the people out, and kills them. In Lepcha *tung kyóng* (ཨ་ལྷོ་ལྷོ་) means ‘corner’ or ‘angle’. This Lepcha word was then corrupted to the present village name (Netuk, *bóngthíng* of Lingthem, April 2006, October 2008). The *bóngthíng* from Sapho says that a bird called Kahryo fo³⁰ already tries to kill Lásó múng in Sakyong by making a trap with a lot of arrows, but he then has to run away from the evil spirit towards Pentong (Dichen, *bóngthíng* of Sapho, January 2009). So, the Lásó múng flies to where at present the village of Pentong lies. Here he collects the people together into bundles and eats them. The Lepcha word *pen* (པེན་) means to ‘take like a bundle’ and *thóng* (ཨ་ཏོང་) ‘to drink’³¹ (Netuk, *bóngthíng* of Lingthem, April 2006, October 2008). All this time the gods are chasing him. Lásó múng then comes to a place now known as Vol. There he kills people by carrying (*vól* (འོལ་), ‘to carry something over the shoulder’) (Netuk, *bóngthíng* of Lingthem, April 2006). Afterwards he arrives in Lingya where he slaughters the inhabitants in a very disgusting way. In Lepcha it should actually mean *gil yol*.³² As a next destination Gorer mentions the locality of Thongto but neither does he recount how Lásó múng kills nor does he give the origin of its name (Gorer 1996: 55). In Laven there are two versions of how the evil spirit murders. He might execute the people by throwing them away (*vyel*, བྱེལ་, ‘wave’³³) or he asks them questions about who they are and what they are doing before he takes their lives (*vyet*, བྱེལ་, ‘question, inquire’) (Netuk, *bóngthíng* of Lingthem, April 2006, October 2008). The gods chase Lásó múng further to Tingvong where he kills the people by rotating them (*vúng*, འོལ་, ‘rotate, turn, revolve’). He continues his flight to where the village of Lingdem can now be found. The name comes from the Lepcha word *duma duma*, which

²⁹ Gorer does not give any further information to who this person or supernatural being is supposed to be. So far no further references or additional information could be found.

³⁰ This bird also takes on an important role in killing Lásó múng in the Dzongu version, see later on in this article.

³¹ *Tong* (ཨ་ཏོང་) also means ‘to gather, extinct, vanish’. The Lepcha word *pen* is translated by Kachyo Lepcha from Lingthem village.

³² Translated by Kachyo Lepcha from Lingthem village.

³³ The word *vyel* ‘wave’ illustrates the way Lásó múng is throwing the people. He is flying in the air and making a waving movement with his hands. During this action he drops his victims and kills them (Kachyo Lepcha, Gangtok, July 2009).

means as much as everyone (*du*, འ), to gather, collect) (N.T. Tamsang 2005: 89). Here the demon goes wild and massacres everyone, even children (Netuk, *bóngthíng* of Lingthem, October 2008; Gorer 1996: 55). The next place the evil spirit flies to according to Gorer is Adong, but again no further information is given. Then he carries on to the present-day village Lingthem. There are different versions of how the Lepchas are killed at this specific spot. He either tortures them by chasing them up and down, the Lepcha word *líng* (ལྷ) meaning upwards³⁴ and *them* (མ) meaning downwards³⁵ (Netuk, *bóngthíng* of Lingthem, October 2008). Or he kills them by squashing them together into his stomach (*tem*, མེ, “to fill or cram ones stomach with food, [...] to fill by forcing something into it” (K.P. Tamsang 1980: 449, Netuk, *bóngthíng* of Lingthem, April 2006), or by eating them each in turn, *tem-la*, *tem-la*, *taa*³⁶ (Gorer 1996: 55). All this time the gods are still chasing the evil spirit. Láso múng flies to Lik on the other side of the valley. This name is derived from the Lepcha word *lik* (ལྷ) ‘to cry or call’. The people are calling out from there when he comes to kill them (Netuk, *bóngthíng* of Lingthem, October 2008; Gorer 1996: 55).³⁷ Then Láso múng continues southeast towards Lingdong where he darts and catches people with quick and sudden movements (Netuk, *bóngthíng* of Lingthem, October 2008), or he has to look for the people first because they are hiding (*dóng* (འཇ) ‘seek, search’) (Netuk, *bóngthíng* of Lingthem, April 2006).³⁸ Then Láso múng flies on to Hee Gyathang.

³⁴ This translation is given by Kachyo Lepcha from Lingthem. *Lingla* (ལྷ ལྷ) can be translated as “sloping. *adv.* in a sloping manner, slantingly” (K.P. Tamsang 1980: 852).

³⁵ This translation is given by Kachyo Lepcha from Lingthem. In the dictionaries the word *them* (མ) is translated as ‘double’. In combination the words *líng them* (ལྷ མ) would mean ‘two times in a sloping manner’. Láso múng chases them two times on a slope, he chases them up and down.

³⁶ This saying is also derived from the Lepcha word *tem*, it is used twice to emphasise that the person is stuffing himself and eating non-stop (Kachyo Lepcha, Gangtok, July 2009).

³⁷ At this point Gorer stops mentioning the villages with the remark that all village names seem to be derived from this story so there is no point in mentioning more (Gorer 1996: 55).

³⁸ *Líng* (ལྷ) means ‘unbalanced, not even, sloping’, the word can also be used to describe a sudden, flowing movement as when water suddenly flushes down a hill (Kachyo Lepcha, Gangtok, July 2009). The last part of the village name could be derived from the Lepcha word *du* (འ) ‘to gather, collect’ (N.T. Tamsang 2005: 89).

This village name comes from the Lepcha word *gyathang*, which means own self.³⁹ Here he himself decides randomly who will live and who will die (Netuk, *bóngthíng* of Lingthem, October 2008). Another explanation is that he kills the people there by collecting and destroying them (*tong*, འཇུག, gather, extinct (N.T. Tamsang 2005: 72, Netuk, *bóngthíng* of Lingthem, April 2006). The next place he reaches got named Suklur because there he makes fluid out of the slaughtered people (*klur*, ལྷོ, ‘to mix, make liquid’).⁴⁰ Then Lásó múng carries on to Tariang in Lower Dzongu where he kills the people by making the sound of a crow. In Lepcha the word *ryáng* (རྟམུ) means crow (Netuk, *bóngthíng* of Lingthem, October 2008). Some narrators also mention other village names like Mangan, Dikchu or Nampok (Dawa, *bóngthíng* of Lingdem, January 2009).

The Cycle of Animals: Lepcha Year

In versions of the Lásó múng story mainly collected from or published by members of Sikkimese Lepcha associations a different version of the pursuit of Lásó múng is given. Jor *bóngthíng* chases Lásó múng for a time period of twelve years, while the evil spirit uses his magical powers to change his appearance. This also gives an explanation for the actual name of the evil spirit – the one who changes his appearance:

God sent *Jor Bongthing*, bestowing upon him, full supernatural powers. He waged a long war with the King *Lasho Mung Punu* for twelve years. The demon King had the power to create illusion by changing himself into the form of different animals. Each year he took the form of an animal. He changed into the forms of mouse, ox, tiger, eagle, dragon, snake, horse, sheep, monkey, bird, dog and pig in the period of twelve years.⁴¹ This is how, this system of counting the years

In this case it would mean that Lásó múng is collecting his victims in fast and sudden movements.

³⁹ Translation by Kachyo Lepcha from Lingthem village (Kachyo Lepcha, Gangtok, July 2009).

⁴⁰ Translation by Ingchung Lepcha, Lingthem village, 2006, confirmed by Kachyo Lepcha, Lingthem village (Kachyo Lepcha, Gangtok, July 2009).

⁴¹ In Lepcha the years are called *kalók nám* (ཇུལྷོ, mouse); *lóng nám* (ལུམ, ox); *sathóng nám* (ལུམུའུ, tiger); *kumthyóng nám* (ཇུལྷོའུ, eagle, kite); *sader nám* (ལུམུའུའུ, thunder, as in Tibetan it is also translated as ‘dragon’ (Kachyo, telephone, July 2009; Karma, Gangtok, July 2009)); *bu nám* (ལུམུ, snake); *ún nám* (ཇུལྷོ, horse (N.T. Tamsang 2005: 30); *luk nám* (ལུམུ, sheep); *sahu nám* (ལུམུའུ, monkey); *hik nám* (ཇུལྷོ, domestic fowl, hen, rooster, the actual word used is not *fo* (ཇུལྷོ) bird, but hen. This could stem

or age of a person in terms of the names of these animals, reckoned chronologically in cycles, each cycle of twelve years, came into practice (Gurung/Lama 2004, revised RMRT 2005: 18; see also Karma Loday 1999: 3; Tom Tshering Lepcha 2003: 3; Tom Tshering Lepcha 2004: 3).

The Lepcha calendar therefore has a cycle of twelve years (*nám kor*, འུལྷ), each year being named after animals. With one exception the sequence of animal names is the same as in the Tibetan calendar⁴². The fourth year in the cycle is called *kumthyóng nám* (ཨྱུལྷ འུལྷ) in Lepcha, the eagle year, but the hare year in the Tibetan version. In Siiger's ethnography the fifth year is not called dragon year as in Tibetan, but "*sá dyār nam*" (Siiger 1967: 80). Siiger translates this as the thunderbolt year, but the Lepcha word *sader* (ལྷམྱ) actually means 'thunder' as well as 'dragon'. Similarly, the Tibetan word '*brug*' has the same double meaning (Saul Mullard July 2009).

In other narrations the evil spirit changes his form, but without a chronology. Consequently no reference is made to the Lepcha calendar. In the Lepcha book *Ahbong chyokung sung* Lásó múng lives disguised as different animals and hides in the Sanyól kúng after killing Lepcha people (Simick 2001: 16). Foning mentions additional animals such as insects:

In the course of retreat, with the help of his occult powers, he kept changing his form from that of one creature to another. Sometimes he became a bird, then took the form of an insect, then again changed himself into a wild boar and so on (Foning 1987: 128).

In Kotturan's narration Lásó múng turns into different animals so he can use their abilities to kill Támsáng thínġ. He transforms into a tiger to rip the supernatural being into pieces, then he turns into a horse to hit him with his hooves, and at last he becomes an eagle to fly away (Kotturan 1989: 23). In this version he is killed in the form of a bird

from the Tibetan usage of the word *bya*. It means bird, but is commonly used for chicken (Discussion Saul Mullard July 2009); *kajú nám* (ཨྱུལྷ), dog); *món nám* (ལྷམྱ, pig).

⁴² The Tibetan calendar does not only have a twelve year cycle like the Lepcha one, but a 60-year cycle (*rab byung*) which contains twelve animal names in combination with five elements (fire, earth, iron, water, wood). The animal signs are as follows: *byi* (mouse), *glang* (ox), *stag* (tiger), *wos* (hare), '*brug* (dragon or thunder), *sbrul* (snake), *rta* (horse), *lug* (sheep), *sprel* (monkey), *bya* (bird), *khyi* (dog), *phag* (pig) (Saul Mullard July 2009). Interestingly, the five elements correspond with the Lepcha names for the week as will be shown later on in this article.

whereas in most others it is in form of a pig – as the pig year is the last one in the twelve-year cycle.

Tom Tshering Lepcha combines the transformation of Láso múng into different kinds of animals with the Dzongu version of the pursuit. According to him this part of the story happened when the evil spirit was in the form of an eagle. This is an interesting suggestion to integrate the two parts of the chase with each other as in Dzongu Láso múng is often called a bird.

Laso Mung Punu during the physical appearance of an eagle having [been, J.B.] wounded by arrow of Jor Bongthing flew painfully and randomly over upper Dzongu of North Sikkim. It is learnt from venerated persons that the names of places like Lungthem (Lingthem), Lungdom (Lingdem), Laven, Tungvung (Tinvong), Leek, etc. originated during the war with Jor Bongthing and Laso Mung Punu in Eagle form (Tom Tshering Lepcha 2004: 3).

Scattering Lepchas – the flight of the people

Before and while the gods or protagonists are chasing Láso múng, the Lepcha people are running and hiding from the evil spirit. In two versions printed in Kalimpong the flight of the Lepcha people from the demon is combined with a story of emigration. The Lepcha people originate from the slopes of the Kangchendzonga and populate other parts of northeast India and Tibet when running away from this demon.

Since the 17th Century each and every one who writes something about the Lepchas, harps the same old tune that the Lepchas may have migrated from either east, west, north or south, but have they ever thought of this that in the dim past, it was the Lepchas that had migrated from Sikkim to the north and from thence to the east and south east Asian countries? The Lepcha's traditions says that in the beginning, when Lasomoong Pano, the demon King and his followers gave unbearable trouble to the Lepchas, they had no other way to save themselves but to run away from the country. And as such, thousands and thousands of Lepchas had fled towards Tibet crossing the Himalayas. It is said that they followed up the river course of Rungfi river, that springs out of from Syisyoong lake and when they arrived at the confluence of Ranfi river and U-Ung river, they then followed up the course of the U-Ung river and then arrived at Taloong glaciers, from thence, they crossed Taloong glaciers, Kisyoong Hlo, Jyakthaong, Taela and Hlonaok mountains, and then entered into Tibet and fled eastwards following the border land of Tibet and the Himalayas. And while fleeing in panic, many went eastward and settled down in China and many entered into Assam following the Brahmaputra river course

and settled down there and many more moved further southwards to Tipura, Chittagong and thence entered into Burma. It is said by the aged Lepchas that the Nagas, Khasis, Mizos, Mugs are the very descendants of those migrated Lepchas that fled from Sikkim to Assam in the dim past and therefore, many Nagas, and other tribal spoken words, numbers, customs, dress, culture and features are much similar like that of the Lepchas. This Lepcha version intimates clearly that the Lepchas have not migrated from the east to Sikkim but it is the Lepchas that had migrated from Sikkim to the northeast India and to the south, east Asian countries. Also, in this flight, many Lepchas had fled southwards following the river course of Romom river that springs out from Tanotangseng lake. In Lepcha language, the meaning of Romom river is the frightened river, that is the Lepchas were thrown into great panic by the demon king and therefore, they fled southwards following this Romom river's course and came to the plain land of Daramden in the Western Sikkim and settled down there, where later on, it is those very Lepchas who built up the Lepcha's earthen tower to go to heaven at Tallaompartam (K.P. Tamsang 1998: 5,6; see also Sonam Tshering Tamsang, translation by Lyangsong Tamsang 1999: 33).

This mythological explanation has to be seen in the context of the discussion of origin, migration, and indigeneity. Anthropologists, linguists, and historians have discussed the origin of the Lepcha people and suggest immigration waves into the Sub-Himalayan region from various directions. Historical and ethno-linguistic data give evidence that the Lepcha have been settled in the region at least since the twelfth or thirteenth century, but no clear date of immigration can be given. Due to linguistic and cultural similarities of the Lepcha, the Kiranti and the ethnic groups in northeast India some researchers assume that the Lepcha migrated from the East together with these other groups (Mackean 1920: 511; Siiger 1967: 27; Sprigg 1982: 16-31). Other researchers hypothesise that the Lepcha are early immigrants from Tibet (Risley 1972: i; Beauvoir Stocks 1975: 7). The myth of Láso múng is used to describe a different migration movement – the emigration of the Lepcha people out of their home area – to explain the similarities between different tribal groups and validate indigeneity to the present area.

DEATH OF LÁSO MÚNG

The last part of the *lúngten sung* describes the killing, mutilation, and death of Láso múng. Again there are narrative strands with slight variations and emphasis on different elements, some of which can also

be found combined with each other. The gods or the supernatural being chase Láso múng either to Láso lyáng (version of the *bóngthíngs* in Dzongu) or to Sukvyer purtám⁴³ (Karma Loday 1999: 3; Gurung/Lama 2004, revised RMRT 2005: 18; Tom Tshering 2003: 3; Tom Tshering Lepcha 2004: 3; Lyangsong Tamsang 2008: 9). Sources says the plain is somewhere near Sakyong Pentong (Gurung/Lama 2004, revised RMRT 2005: 18). This location seems strange because during the pursuit the evil spirit is flying from north to south, but also coincides with a version from Dzongu in which an attempt is made to kill Láso múng at Sakyong (Dichen, *bóngthíng* of Sapho, January 2009). Other narrators think it is more likely to be in the south, towards the plains. In South Sikkim the pursuit of Láso múng has left traces in the landscape. In Lachenthang in South Sikkim the evil spirit hid behind a boulder and Jor *bóngthíng* is said to have smashed it apart. The two halves of the boulder with foot- and handprints on them can still be seen there (Gurung/Lama 2004, revised RMRT 2005: 18).⁴⁴ In Gorer's version Láso múng is killed in the valley of the Teesta, to the west of Dzongu, and a huge rock formation can still be seen where his body turned into stone (Gorer 1996: 55).

Destroying the body 1: weekdays

After the supernatural being, in this narrative strand of the story it is usually Jor *bóngthíng*, has killed the demon, the Lepcha go to see if Láso múng is actually dead. To make sure the evil spirit cannot resurrect, they mutilate his body. Every day someone uses different methods to check on the body or to further destroy it. This procedure continues for seven days and the various materials used give the names for the Lepcha weekdays.

Seeing their dreaded foe dying, no one ventured to go near him as the Lepchas had seen the black magic of the demon. They all had seen his different forms into which he had changed during the long battle. After some time one brave Lepcha went slowly towards their fallen enemy to make sure about his death. He first threw stones at the body of the demon lying on the ground. As the demon did not get up he went close to the body and found that his body was still warm and the pulse was still beating faintly. He came back towards his friend and told them

⁴³ *Sukvyer* (ལུ་ལྷོ་ལྷོ་) means 'mud' in Lepcha and *purtám* (པུར་ཐམ་) 'plain ground'. Lyangsong Tamsang (2008: 9) and K.P. Tamsang call the place 'the valley of death'.

⁴⁴ Today there is no village or place heard of in South Sikkim called Lachenthang and the boulder is unknown.

about what he actually saw and felt. They waited for a long time but the demon did not get up. Next day, another man went towards the demon and beat the demon with a wooden stick. He felt the pulse of the demon and found it still beating. So he took out the eyes of the demon. The following day another man went and cut down the parts of the body with the help of weapons made of iron. As it was evident that the demon was dead by now, people went and covered the body parts with earth. On the fifth day, the people decided that they should destroy the parts of the body further and burnt them, with fire, to ashes. On the sixth day, they threw the ashes into the air. On the seventh day, they washed the ashes that had remained on the ground with water. This is how the seven days of a week were named according to the materials or weapons used for the destruction of the demon i.e., *Long* (stone) *Sayak*, *Kung* (wood) *Sayak*, *Punzeng* (iron) *Sayak*, *Fat* (earth) *Sayak*, *Mee* (fire) *Sayak*, *Sukmut* (air) *Sayak* and *Ung* (water) *Sayak* (Gurung/Lama 2004, revised RMRT 2005: 9⁴⁵; see Karma Loday Lepcha 1999: 3; Tom Tshering Lepcha 2003: 3; Tom Tshering Lepcha 2004: 3).

According to Karma Loday Lepcha, General Secretary of the Sikkim Lepcha Association, the Lepcha week starts on Friday, the stone day. Namgyal Lepcha, ex-President of the Mutanchi Lom Aal Shezum (MLAS), names the same materials as weekdays, but starts with iron and ends with wood, slightly altering the narrative. In his version the Lepcha people poke Láso múng with iron arrowheads. Then on the second day he falls down to the ground, after being fatally wounded by the arrow, this is the reason why the second day is named earth day. Fire and air day are described exactly the same as in the quote. On the fifth day the water is not used to wash away the ashes from the ground, but to wash it off the hands and bodies of the gods who burnt and distributed the ashes of the evil spirit. On the sixth day stones are thrown everywhere and the evil spirit asked not to come back, and on the seventh day the procedure is repeated with sticks. This is why these days are called the stone and wood day respectively (Namgyal Lepcha, ex-President MLAS, Passingdang 2009). Siiger mentions that in Tingvong in Dzongu the villagers use different week names which is probably due to Tibetan influence. These names have nothing to do with the story of Láso múng but are attributed to celestial bodies as in Tibetan: “*za nyi ma* (Sunday) [is ascribed] to the sun, *za da o* (Monday) to the moon, *mik mar* (Tuesday) to Mars, *hlak bo* (Wednesday) to

⁴⁵ In the published version of the Láso múng story (Gurung/Lama 2004: 112, 113) the names of the weekdays are not mentioned. It solely describes the creation of Lepcha clans due to the slaughtering of the evil spirit.

Mercury, a deity blessing by his hands, *phur bo* (Thursday) to Jupiter, the deity of the thunderbolt, *pa sang* (Friday) to Venus, the deity of peace and happiness, and *phem bo* (Saturday) to Saturn, the deity of mercy.” (Siiger 1967: 77). Today, these names are not commonly used; even the Lepcha names are heard less and less frequently. In everyday usage days are named either in English or Nepali language.

Destroying the body 2: Rongkati and Lepcha clans

In this narrative branch of the death of Láso múng the first ten Lepcha clans come into existence. They are derived from the activities whilst fighting and killing the evil spirit. It is commonly told in the Kalimpong area and active members of the Lepcha community in South and West Sikkim. In its basic pattern the process of the mutilation is similar to the branch of the story explaining the names of the weekdays.

Among those who had come to slay the demon, the bravest plucked up courage and creeping forward, examined the heart beat and the breathing. Coming back to his companions who were standing some distance away, he reported the condition of the *mung* to them. Then another ventured forth. Finding the body of the *mung* still warm, he thought he might come back to life again, so, even if it had happened, he thought by destroying his eyes he would be handicapped badly. Thinking thus, taking his spear, he punctured his two eye balls. Then the third came forward, and apprehending danger from the ogre’s magical powers, set about dismembering his limbs from the trunk. He also chopped off his head with his ‘ban-pok’. Then came another, who, finding the dismembered limbs twitching, proceeded to slice out the muscles from the bones and started crushing the bones on rocks and boulders. After seeing these things being done, everybody came and, cutting up the flesh into small and minute bits, they flung them all around (Foning 1987: 128; see Lyangsong Tamsang 2008 and Kotturan 1989 for similar versions).

So again the breathing is checked, the eyes are taken out, the body is cut apart, and then thrown away through the air. In this branch the actions do not explain time, but one of the main elements of social organisation – the existence of clans (putsho, རྩེལ་ལོ་).⁴⁶ Tamsang thing gives the ten different people (or groups of people) who kill the demon

⁴⁶ The suffix *-mú* (འུ་) is used to indicate a clan or the origin from a certain place. The same word also means mother.

different titles according to their participation. The *róng kati* (ᠷᠣᠩᠠᠵᠢ)⁴⁷ are made leaders of ten different lineages. These are today considered the first ten Lepcha clans and every clan should be able to trace its ancestry back to one of them. Moreover, the direct descendents of those involved in killing the evil spirit are supposed to have honoured position in the Lepcha community (Siiger 1972: 241). In his newest publication Lyangsong Tamsang gives a list of the actions and clan names, sometimes explaining why the specific Lepcha word is used:⁴⁸

1. The Lepchas who prayed, remembered Itboo-Deboo, the Creator, and requested Him to deliver the Lepchas from the clutches of the devil, Lāso Mung Pano, were given the title of ‘Munlaonmmoo’.⁴⁹
2. Those Lepchas who made and prepared weapons like swords, Banmaok, etc. to fight against the devil, they were called ‘Karvomoo’.⁵⁰
3. Those Lepchas who served Tāmsāngthing, Nyolik Nysong Mun, Azaor Bongthing, and Lepcha leaders during the battle against the devil were given the title of ‘Adenmoo’.⁵¹
4. Those Lepchas who helped to make bows and arrows to fight Lāso Mung Pano were called ‘Phyoong Tālimmoo’.
5. Water, rations and food suppliers were given the title of ‘Joriboo’.⁵²

⁴⁷ *Róng* is the short form of the endonym for Lepcha, *kati* means ‘ten’. In K.P. Tamsang’s Dictionary the *róng kati* are explained as followed “ten Lepchas. *n.* the ten Lepcha patriarchs the earlier Lepcha personages regarded as the fathers of human race, comprising those from Fodong Thing to Tamsang Thing and those between the Deluge and the birth of Thikoong Tek. After conquering Laso Moong Panoo, Tamsang Thing created the ten Lepcha patriarchs, from whom descended the ten male head of a tribal line. The ten elders or leading older members of the ten Lepcha tribes who advise and help the Lepcha king to rule the land” (K.P. Tamsang 1980: 788).

⁴⁸ When Lyangsong Tamsang does not give explanations, I will add them in footnotes so that the reason for the Lepcha names given to the clans is clear.

⁴⁹ *Mun* (ᠮᠤᠨ) is a type of Lepcha ritual specialist; *lóm* (ᠯᠣᠮ) ‘way’ or ‘path’. This means they are taking the way of the Lepcha priest, i.e. they are praying. The suffix - *mú* (ᠮᠤ) relates to clan or place.

⁵⁰ *Kárvo* (ᠵᠠᠷᠪᠣ) ‘smith’, ‘someone who works with metal’.

⁵¹ I am not sure why the leaders are called Adenmú. The Lepcha word *áden* (ᠠᠳᠢᠨ) is translated as ‘fledging, having the wings developed for flight’. This could indicated that they were the most able to follow the flying evil spirit and therefore became leaders. Kachyo says, the same word *áden* (ᠠᠳᠢᠨ) is also used for the verb ‘to lead’ (Kachyo, Gangtok, July 2009), but this translation cannot be found in the two dictionaries available.

⁵² *Zo* (ᠵᠠ) is Lepcha for ‘rice’ and *ribú* (ᠷᠢᠪᠤ) for ‘distributor’ (see also Foning 1987: 128).

6. Those Lepchas who constructed and made bridges, roads, ropes and bow-strings were called ‘Brimoo’.⁵³

7. The Lepcha who dared to check if Lāso Mung Pano’s heart was beating and he was breathing was given the title of ‘Lutsaom moo’. In Lepcha ‘Ālut’ means heart and ‘Āsaom’ means breath and if you remove the two common prefixes ‘Ā’, it becomes ‘Lutsaom’.

8. The person who broke the eyes and blinded the devil was called ‘Seemickmoo’.⁵⁴

9. The Lepcha who separated Lāso Mung Pano’s head and legs with his ‘Banmaok’ was called ‘Sungngootmoo’.⁵⁵

10. The Lepcha who beat up, crushed the body of Lāso Mung Pano into dust and blown them into thin air from a hill top was given the title of ‘Sungdyāngmoo’⁵⁶ (Lyangsong Tamsang 2008: 9, 10).

Other versions are similar, but most are not as detailed (Foning 1987; Koturran 1989; Beauvoir Stocks 1975; Jest 1960). Foning only names seven clans and explains Adenmú and Manlommú differently. The people named Adenmú are those who make the seats for the celebration after the death of the evil spirit because *den* in Lepcha means ‘carpet seat’, and Manlommú are those people who offer thanks to Ítbú debú rum at the end, and not those who ask for help in the beginning (Foning 1987: 128). Jest’s version gives certain different activities containing more details of the mutilation and clan names:

The first hunter split open his skull, wherefore his family took the name *só-t’a-mo*. The second hunter struck him in the eyes and his family was called *so-mik-mo*. The third hunter tore out the tongue, and his family was called *fok-li-mo*. The next one cut off the demon’s buttocks and his descendants were called *so(m)-bur-mo*. Another hunter cut off the beard and his family was called *só-mot-mo*. Other hunters who had only the limbs to hack received no family names. Those who remained at home discussing the affair, received the name of *nan-tsö-mo*. Those who had constructed a cane bridge in the course of the hunt were called *sóm-pŭ-mo*⁵⁷ (Jest 1960: 126, 127).

⁵³ *Brí* (འབྲེག) means ‘to combine’ in Lepcha.

⁵⁴ The Lepcha word *mík* (འཇོམ་པོ་) is ‘eye’.

⁵⁵ *Ngút* (འཇོམ་པོ་) can be translated as ‘to cut or to severe, divide by a knife’ (see also Foning 1987: 128).

⁵⁶ *Dyáng* (འཇོམ་པོ་) is translated as ‘to pound or crush fine’ (see also Foning 1987: 128).

⁵⁷ “It is possible to interpret most of these names with reasonable plausibility: *só-t’a-mo*, killing-skull-folk; *so-mik-mo*, killing-eye-folk; *fok-li-mo*, tearing-tongue-folk;

Siiger collects a version from a certain Sadam Tsering from Kalimpong of which the basic idea is the same, but the clan names are different and again a more exhaustive mutilation of the body is described. Further, the clan names are not given by the supernatural being, but by the evil spirit itself, or in the end by the king:

Immediately the people rushed at the *mung*, and tore him into pieces. Some of them took his eyes, some his hair, some an ear, some the nose and so on.

The man who collected the people to fight against the *mung* became the ancestor of Adinmo *pũ tsho*. This name was given to him by the *mung* before he died.

The *mung* told those who took an eye that their *pũ tsho* should be called Samik *pũ tsho*. [...] From this time this *pũ tsho* came into being. [...]

The *mung* told those who took an ear got the *pũ tsho* called Gormu. Those who took the hair got the *pũ tsho* called Sadamu. Those who took the nose got the *pũ tsho* called Fo Gramu. Those who took the tongue got the *pũ tsho* called Fi Glimu. Those who weighed [sic!] the body of the *mung* got the *pũ tsho* called Fo Ning Ramsongmu. Those who cut off the fingers of the *mung* got the *pũ tsho* called Sadingmu. Those who cut off the toes of the *mung* got the *pũ tsho* called Sangdyangmo. And many other people got their *pũ tsho* names in this way.

There was also an astrologer who divined by his books in which manner they must kill the *mung*. The *mung* therefore gave him the *pũ tsho* called Namtsumo. [...]

There were, however, some who obtained no *pũ tsho*. They went to the Maharajah and asked for a *pũ tsho*, and he gave each of them a *pũ tsho*. Those who presented some vegetables to the Maharaja were given the *pũ tsho* called Pache Shanga. Those who presented a small bird called Kohum [...] secured the *pũ tsho* called Kakum Shanga (Siiger 1967: 113, 114).⁵⁸

K.P. Tamsang does not give each clan in detail, but says Tamsang thing gave title and honour to 108 Lepcha warriors and at the same time assigned each of them a mountain peak as a guardian (K.P. Tamsang 1998: 39). Here an important concept of clan is addressed. In the Lepcha community every clan is linked to a mountain peak (*cú*, ལུ), a lake (*dâ*, ལྷ) and an entry point (*lep*, ལེཔ). The mountain peak is referred to as the male component and the lake as the female one. The entry

só-māt-mo, killing-beard-folk; *nan-tsó-mo*, inside-discussing-folk ; *só(m)-pũ-mo*, bridge folk” (Jest 1960: 127).

⁵⁸ For another version of the mutilation see Simick 2001: 18, 19.

point is where the soul comes from and is guided back to by the *mun* after a person dies.

Again combinations of the different narrative strands exist. Tom Tshering Lepcha and Namgyal Lepcha both mention the *róng kati* as the main people helping Jor bǒngthǐng slay Láso múng, however then do not recount the formation of clans from the activities, but explain the names of the weekdays (Tom Tshering Lepcha 2004: 3; Namgyal Lepcha, ex-President MLAS, October 2008). In the revised Sikkim Study Series both branches are told shortened but combined (Gurung/Lama 2004, revised RMRT 2005: 10, 11).

Poisonous lake – the Dzongu version

The elders and ritual specialists in Dzongu have their own storyline on the killing of Láso múng. The gods chase the evil spirit to a place called Láso lyáng and then discuss how he can be killed. They resolve that the evil spirit is obviously attracted by human blood so they decide to make a trap for the evil spirit. They create a lake out of blood (*vi*, བེ), mix poison (*nyung*, རྩུང) into it and place upright arrows and spears in it that just reach until under the surface. The trap is set, but Láso múng does not come. The gods are just contemplating how they could lure the demon when a small bird offers its help, the Kahryo fo (ཨ་ལྷོ་ཏོ).⁵⁹

There is a bird called Kahryo fo. He addresses the gods: ‘Give me a white cover on my head and I will make Láso múng jump into the blood and poison lake.’ Now today the head of this bird is still white as the gods granted his wish.

The bird flies over the lake, sits on the top of one of the spearheads, and starts hopping around, singing and dancing. Then he challenges Láso múng, mocking him, telling him, he is so strong and has such a huge body, but still is afraid of entering the lake and do what a little bird can do. ‘I am jumping on the tip of the arrow, and you have so much strength and power and still you are such a coward’. Láso múng gets angry because a small bird is challenging him like this. So he jumps and all the spears and arrows pierce his body. In this way Láso múng is killed and all the human beings are finally at peace (Netuk, *bǒngthǐng* of Lingthem, October 2008; see also Netuk, *bǒngthǐng* of Lingthem, April 2006; Dichen, *bǒngthǐng* of Sapho, January 2009;

⁵⁹ Kahryo fo (ཨ་ལྷོ་ཏོ) is “the white crested laughing thrush bird. n. a passerine bird belonging to the family *Turdidae*, gifted as songster, *Gerrulax leucopolus*” (K.P. Tamsang 1980: 162).

Dawa, *bóngthíng* of Lingdem, January 2009; Merik, *bóngthíng* of Linko, December 2009).

Again within the narrative a characteristic of an animal is explained as a gift given by the gods for a deed the specific animal did.⁶⁰ The Kahryo fo is still very important for the Lepcha community. Gorer mentions this bird in his account on Lásó múng, but in a different way. In his narration also collected in Lingthem, this little predatory bird is one of the animals that develop out of the flesh and bones of the demon (Gorer 1996: 55).

REJOICING – LEPCHA NEW YEAR (NÁMSÚNG OR NÁMBUN)

Lásó múng, the most vicious evil spirit, tortures and murders Lepcha people for a long time and at the event of his death they gather to celebrate the victory and liberation. The festivities last for seven days, just as long as it took to dispose the body of the demon. For this purpose they gather at a place called Tárkól tám i tám.⁶¹ This mythological celebration is considered the first New Year celebration – yet again the story of Lásó múng explains the concept of time. After killing the evil spirit a new life, a new year, can begin⁶² (see Foning 1987: 128; Kotturan 1989: 28; Karma Loday Lepcha 1999: 3; Tom Tshering Lepcha 2003: 3; Tom Tshering Lepcha 2004: 3). Even though the ritual specialists from Dzongu do not mention the transformation of Lásó múng and the twelve-year cycle, nor the mutilation of the demon's body and the names of the weekdays, some of them relate the narration of Lásó múng to the celebration of Námsung (such as Netuk, *bóngthíng* of Lingthem, October 2008 and Dichen, *bóngthíng* of Sapho,

⁶⁰ In many Lepcha stories the existence of animals or certain characteristics of animals are explained, sometimes as main protagonists, sometimes also just in a sentence on the side. In some versions of the Lásó múng story the leftovers of the mutilated body that are thrown away into the wind turn into evil blood sucking insects such as leeches or mosquitoes (see Beauvoir Stocks 1975: 29; Gorer 1996: 55; Kotturan 1989: 26, 58; Foning 1987: 128) or even new forms of evil spirits (Jest 1960: 127).

⁶¹ The Lepcha word *tár* (ཨྱ) means 'to deliver, set free, liberate or save' (K.P. Tamsang 1980: 419), or 'to progress, advance' (N.T. Tamsang 2005: 71). K.P. Tamsang translates Tárkól tám i tám (ཨྱའུའྱེ་མེ་འྱུ་ཨྱ) as 'the valley of deliverance'. It is also a name for the place in northeastern Sikkim where Tamsang thing kills Lásó múng (K.P. Tamsang 1980: 419).

⁶² The Lepcha word *nám* (འུ) means 'year', *súng* (འུམ) is 'to celebrate or commemorate' whereas *bun* (འུམ) is the past participle of 'carry'. Translated *námsúng* is 'to celebrate the year' and *námbun* would mean 'a year has been carried'.

January 2009), saying the Lepcha rejoiced after the death of the demon. Others strictly decline this connection when asked (*bóngthíng* of Pentong, December 2008, Merik, *bóngthíng* of Linko, October 2008).

The New Year's festivity starts on the last night of the old year with the celebration of *Már nyóm tyángrígóng sonáp* 'black night in the last month of the year'.⁶³ On this evening the Lepcha ritual specialists or in some cases the head of the family will perform a ritual to cleanse the people and drive out the evil of the past year. It is done individually by each household or sometimes by a group of households. In Dzongu the *bóngthíng* addresses various gods to protect the people of the house or the village from different kinds of evil, such as jealousy, and to bring luck, prosperity, and happiness into their lives in the coming year. The most important ritual item is a bundle made out of leaves of the broom plant, called *pashór* (ཁྲུ་མེ)⁶⁴ in Lepcha. After the short ritual the members of the household are cleansed with it. The *bóngthíng* will run it along the body of the person while murmuring prayers. It is also on this night that the effigy of *Láso múng* is burnt in the villages. The effigy can be made of different material (rice, millet, or straw) and often looks like a mixture of a human, a snake, and a dragon. Sometimes small replicas of the twelve animals of the Lepcha calendar are put at the demon's feet. After the cleansing ceremony performed by the Lepcha ritual specialist, the youth of the village will run from house to house, wake the people, get offerings, and drink local millet beer. At exactly midnight, the starting of the New Year, the collected items are offered in a short ceremony and the effigy of the evil spirit is burned down under enthusiastic shouting of the youth. This ritual is more officially called *Láso múng tyút sonáp*,⁶⁵ literally meaning the night *Láso múng* is burnt. The villagers shorten it *Láso múng sonáp*, or jokingly call it *Cí kón sonáp*,⁶⁶ 'the night the local beer is sampled'. This part of the ritual is only done in some villages in Dzongu and was not performed at all until the end of the 1990s when members of the Sikkim Lepcha Youth Association introduced it. They were inspired by a visit to Kalimpong where it is still regularly performed. The *Námsúng*

⁶³ *Már nyóm* (མའི་མཚེས་) is the name of the twelfth month in the Lepcha calendar, *tyángrígóng* (ལྷ་མོ་ལྷ་མོ་) means 'pitch black' and *sonáp* (ལྷ་མོ་) 'night'.

⁶⁴ "elephant grass, which is used by Lepcha priests and priestesses in exorcising evil spirits and in cleansing and purification ceremonies. Its flowers are used for making brooms *Seckarrum* of genus *Cramineal*." (K.P. Tamsang 1980: 537).

⁶⁵ *Tyút* (མཚེས་) means 'to burn or to scar', *sonáp* (ལྷ་མོ་) is translated as 'night'.

⁶⁶ *Cí* (མོ་) is the local millet beer, *kón* (ལྷ་མོ་) means 'to taste, to try'.

celebrations last for one week. On the first day more cleansing ceremonies are performed and the family members stay in the houses. The following days friends and relatives visit each other and groups of young people move through the villages singing traditional songs and performing dances, shouting *ácúle* (མཁུ་ལྷོ་ལྷོ)⁶⁷ on the way. This activity is actually called *láso* (ལཱ་ལྷོ) in Lepcha. Community picnics will be organised. Nowadays big functions are organised with games, traditional food stalls, dance performances, speeches, and other entertainment.

LINKS TO OTHER TRADITIONAL LEPCHA STORIES

Creation of cí

I heard from Namgyal Lepcha, former president of the Mutanchi Lom Aal Shezum (MLAS) in Dzongu, that the traditional narration of *Láso múng* is also connected with the origin of marriage. I did not get the chance to collect this branch of the story from him, but found a Kalimpong version of this respective narrative strand in a recent publication of Lyangsong Tamsang, the president of the Indigenous Lepcha Tribal Association (Lyangsong Tamsang 2008: 5-8). He mentions the fight against *Láso múng* when recounting the traditional Lepcha story of the origin of *cí*, the locally brewed millet beer, the origin of which is usually narrated in the story of the first marriage between *Tárbóng* and *Narip* (see for example Foning 1987: 93-98; Beauvoir Stocks 1975: 25-28; Plaisier forthcoming 2009).

Ítbú debú rum realises the distress of the Lepcha and sees that their morals are too low to win the battle with *Láso múng*. Therefore, she creates *Támsáng thing* and bestows him with supernatural powers to help the Lepcha free themselves from the powerful evil spirit. *Támsáng thing* realises that the Lepcha do not have the self-esteem to fight anymore after years of battle. He then chooses *Nyolík nyosong* to be the first Lepcha *mun* and gives her all supernatural powers in the repertoire of these Lepcha priests. She is supposed to give the Lepcha their confidence back and after facing problems she sends volunteers to get *but* (བུ) (ferment) for making *cí*. This alcoholic beverage should encourage them and give them strength. Eventually with the effect of *cí* they succeed in killing *Láso múng* (Lyangsong Tamsang 2008: 5-8; see

⁶⁷ *Ácúle* (མཁུ་ལྷོ་ལྷོ) can vaguely be translated as ‘praise to the mountains’, it is used as an expression of welcome, joy, or admiration.

also Sonam Tshering Tamsang, translation by Lyangsong Tamsang 1999: 34, 35).

In the Lepcha book on Nyolík nyosong *cí* or nectar, as it is called in the book, is also seen as a means to subdue the most vicious evil spirit which in this case is called Jhyum Pahu Pani:

Then from this time onwards, the deity, Jhor Bongthing began to search the earth for the nectar, Lyam-chi Dyam-chi, to offer it as a consecrated food, that is, to obtain triumph over the demon (Nyu-lik Nyusong, Translation 1992: 12).

Another occurrence also suggests a closer connection between the invention of *cí* and the myth of Lásó múng. When reciting the ritual at Lásó múng sonáp Dichen, the performing ritual specialist from Sapho, gives the first offerings to the guardian of yeast and the cockroach who according to the myth was able to steal the yeast to make *cí* (Dichen, *bóngthíng* of Sapho, January 2009).

The tower of Dharamdin

Another Lepcha myth connected with the wrathful killings of Lásó múng is the legendary story of a pot tower built on a plain field near Dharamdin,⁶⁸ often called the stairway or tower to heaven (Lyangsong Tamsang 2008: 14, 15; Sonam Tshering Tamsang, translation by Lyangsong Tamsang 1999: 33). In the Lepcha myth the place is called Tá lóm purtám (ཨ(ལ(ལྷེ),⁶⁹ meaning ‘the plains where the people went up’ (Lyangsong Tamsang 2008: 14). Briefly summarised in this legend a group of Lepcha people start building a tower to the sky, made out of clay pots. When the tower is high enough the person on top asks for a hook to fix the tower on the firmament but the people on the ground understand that they should smash down the tower. This miscommunication is repeated a few times and eventually the people at the bottom destroy the tower. In past this legend has been ridiculed and certain sections of the Lepcha community have felt embarrassed by this story. Foning describes this feeling well:

⁶⁸ Lyangsong Tamsang explains the name Dharamdin as follows: “‘Da’ in Lepcha means a lake; ‘Raom-dyen’ means to be demolished. To build the Earthen Tower at Tal Loam Purtam, the Lepchas of yore demolished the lake and used the mud, clay of the lake to go to heaven and thus, the name ‘Da Raom-dyen’ in Lepcha. It is erroneously pronounced as ‘Darumdin’ by the non-Lepchas today” (Lyangsong Tamsang 2008: 14, see also Foning 1987: 91).

⁶⁹ Tá (ཨ(‘up, towards’, lóm (ལ(‘path, way’, purtám (ལྷེ) ‘plains’ (N.T. Tamsang 2005: 106).

Now, we of the present time, considering the acts of our progenitors as an act of foolishness, give the appellation of “Na-ong” to a person who shows lack of intelligence and common sense (Foning 1987: 91).

Therefore, because it could give a justification for the ‘foolish act’, the reason why the tower was built becomes important. The most common reason given is that the Lepcha were trying to reach heaven.⁷⁰ Within the Lepcha religious context this explanation seems difficult to understand because the Lepcha traditionally do not have the notion of a heaven in the sky. The closest to heaven would be Rum lyáng, or Púm lyáng,⁷¹ the realm of gods and the place of ancestors where the deceased go. Souls do not enter this place by elevating to the sky, but through places recognised as *lep* (ལེཔ), entry points. These are usually caves or other areas leading into the Himalayan mountains, the seat of gods and ancestors. Which *lep* a soul will use to enter the realm of afterlife depends on the clan of the deceased. T.T. Lepcha, the president of the Sikkim Lepcha Literacy Association, along with other members of the Lepcha community, have thought about this contradiction and find an explanation for it. The Lepcha concept of Máyel lyáng, the holy hidden land where the supernatural people of Mayel live and all prosperity of Lepcha land comes from, is often translated into English as paradise or heaven. In most Lepcha rituals offerings to the mountains and Máyel lyáng are given. During this performance the Lepcha ritual specialist faces the Kangchendzonga mountain range. Now the area where the tower was built is a flat plain in the southwestern part of Sikkim from where the mountains cannot be seen. T.T. Lepcha’s explanation is that the tower was built to be able to see Máyel lyáng and the mountains and in this way address the gods directly in the rituals. They built a tower to see their heaven, their Máyel lyáng, and be nearer to the gods they were worshipping. (T.T. Lepcha, Gangtok, January 2009).

The central idea behind the explanation is that the tower was to be used as an observation tower for the gods or for evil spirits. Tamsang suggests that the tower might have been built to be close to the creator deity whom the people were calling on for protection against Lásó

⁷⁰ In his book on *Folktales of Sikkim* Kotturan gives a completely different reason: some wise Lepcha men are debating how far the distance is between earth and sky and decide to build the tower to find out (Kotturan 1989: 69-71).

⁷¹ *Púm* (པུམ) can be translated as ‘origin’, *púmthín* (པུམ་ཐིན་) is an ‘ancestor’ and *lyáng* (ལཱུང་) means ‘land’.

múng, but it could also have been built to observe the movements of the evil spirit (Lyangsong Tamsang 2008: 15).

Another version of the story of the earthen pots collected in South Sikkim is even more connected to Láso múng. The Lepcha from Sakyong and Pentong fled the demon as they knew he would kill all of them. They followed the rivers⁷² and came all the way south to Dharamdin. There they settle, but still do not feel safe and fear the demon will find them. Therefore, they decide to build a tower to a place, outside of the earth, where they can live without fear (Phur Tshering Lepcha, Namthang, July 2009).

ORAL TRADITION AS REFLEXION OF CULTURE: CREATING TIME, MAPPING SPACE AND EXPLAINING RELIGIOUS AND SOCIAL ORGANISATION IN THE MYTH OF LÁSO MÚNG

With its many narrative strands and localised versions the myth of Láso múng maps Lepcha land, time, and aspects of religion as well as social organisation. The story is linked to many important Lepcha myths such as the story of creation, of the origin of *cí*, and of the pot tower near Dharamdin, as well as to two community rituals, *Sátáp rum fat* and *Námsúng*, the New Year celebration. It explains fundamental elements of Lepcha belief, such as the existence of evil spirits in the world. In Dzongu the pursuit and the killing of Láso múng explain the names of the villages, moulding the mythology into the landscape and everyday life of the Lepcha. The chase of Láso múng explains the twelve-year cycle of the Lepcha calendar and his death gives sense to the Lepcha week as well as clan origin and names. Further characteristics of animals, trees, and mountains peaks and their origin are described. In the following I will give a brief thematic summary.

Creation of humans and evil spirits

The figure of Láso múng is embedded in the main Lepcha *lúngten sung*, the creation story, and explains a core religious concept of Lepcha belief – the existence of evil spirits and human beings. The belief in malevolent beings is one of the main aspects of Lepcha traditional religious practice. Evil spirits cause illness, natural disaster, and death. A deceased person, deprived of human life, can turn into a

⁷² The names of the rivers they come along are derived from the incident. One river is called Roma, *ro* (ལྷ) means ‘fear’ and *ma* (མཐོ) is ‘to hide’; the second river is Lódoma, *ló* (ལྷ) means ‘again’ and *ma* (མཐོ) ‘to hide’.

demon and cause harm if not correctly guided into the land of afterlife. The Lásó múng myth is bound back to the story of creation, of man, of evil spirits, of life and death. It is one of the myths which directly explains how evil came into the world. In some cases Lásó múng is described as the ultimate form of evil. Fadróng thǎng and Nazóng nyú, the Lepcha progenitors, first give birth to evil spirits of which Lásó múng is the oldest and the most vicious. When they were caste away by their parents, the children turn into malevolent beings because they have been deprived of their right to become human. The Lásó múng story also shows that the gods give the Lepcha people means of dealing with the evil spirits. It is linked to the creation of the first Lepcha ritual specialists who are bestowed with powers to appease evil spirits by giving offerings. Different deities or supernatural beings fight Lásó múng. The main characteristic they have in common is that in various ways they are all in charge of appeasing evil spirits. Kumyâ kumshirum summons the malevolent beings to the meeting during which they decide that they will accept offerings as food and leave the Lepcha people alone. Tâmsáng thǎng creates the first Lepcha ritual specialists, and Jor bongthǎng himself is the first ritual specialist.

Summarised, the myth describes how evil came into existence, how the Lepcha people were killed and tormented, but then also how the evil could be combated and at least controlled. It outlines the religious order of the world, divided into gods, evil spirits and humans, with ritual specialists to mediate between the humans and the benevolent and malevolent supernatural beings. This also explains why the myth of Lásó múng can be told in combination with the myth of retrieving ferment and the local millet beer. *Cí* is one of the main elements of sacrifice to the deities as well as the evil spirits. No ritual can be held without it.

Time – weeks, years and life

In the various narrative strands of the Lásó múng myth the cultural measurement of time is explained. The story gives a mythological explanation of the core time units of the Lepcha calendar: the week, year and the twelve-year cycle. Lásó múng is chased by a supernatural being for more than a decade and changes its appearance twelve times. This gives the explanation for the twelve-year cycle in the Lepcha calendar and the name of every year. The mutilation of the demon's body lasts seven days, and the materials and activities give the names of weekdays. The killing of Lásó múng demarks the end of an old age and the beginning of a year, and gives reason for the first New Year

celebration. Further is explains time in a more cultural-biological sense – the span between birth and death. In one version Lásó múng and his brothers kill the first human twins. In consequence of this human beings are born and die whereas evil spirits live for eternity.

Mapping the landscape

Different versions of the Lásó múng narrative explain village and river names as well as elements of the landscape such as boulders in Sikkim and Kalimpong. Most prominently it can be found in the version told by the ritual specialists of Dzongu. The evil spirit flies through the area of Dzongu killing people in various brutal ways while the gods are chasing him. Thus the village names are derived from the different methods the demon uses to murder the people in the specific places. During this flight the area of Dzongu is delimited. The Lásó múng narrative gives a sense of space, binds the origin of all the village names back to one common event and thereby creates a mythological map of Dzongu. This branch of the story is only found in Dzongu and confined to village names in this specific area. Historically the reserve area does not exist as a specific entity with own regulations and sense of identity since more than one hundred years.

In other versions landscape characteristics are explained. Lyangsong Tamsang as an example shows how the people running away from the evil spirit went along streams hiding, thereby giving the places their respective names.⁷³ In K.P. Tamsang and Sonam Tshering Tamsang's account the myth explains a forced emigration of the Lepcha people from their place of origin and home. They are using it to counteract discussions in anthropology, linguistics, and history that the Lepcha might have immigrated from eastern or northern areas. In their narrations the myth maps an area of socio-cultural and linguistic similarities to the Lepcha people and gives a reason as to why the Lepcha people should have been forced to leave their Máyel lyáng. This narrative branch shows a response to research published in the last hundred years and can be seen as a reaction to a discussion on indigenous rights and immigration laws which has become important in politics in the region in the last century.

⁷³ See also boulder mentioned in Gorer 1996: 55 and in Gurung/Lama 2004, revised RMRT 2005: 18. River and place names are also given by Phur Tshering Lepcha of Namthang (July 2009).

Róng kati – the creation of the first Lepcha clans

In Kalimpong the narrative of Lásó múng is the main myth used to explain the origin of clan structure in Lepcha society. Before the slaying of Lásó múng the Lepcha community had no distinction into different lineages, then Támsáng thing gives the people involved in the killing various titles. It is said that ten titles were distributed. These ten people or groups rewarded after the killing are known as *rong kati*, the ten Lepchas. The titles were given on to the descendents and in this way the successful mutilation of the evil spirit introduces a segmentary system of social organisation. There are hints that this story also explains a more hierarchical structure of social organisation, as the descendents of those who participated in the slaying of Lásó múng seem to have a higher social standing. The designation *rong kati* is also used to describe the political structure of the village. In certain Lepcha areas there was a council of ten elders or leading older members of the community who would act as advisors.

Conclusion

The myth of Lásó múng portrays important aspects of Lepcha culture and religion; it has been shaped by local surroundings and can be described as reflexion of Lepcha culture on itself. In this article the various narrative strands and localised versions found in the collected versions of the Lásó múng story were laid out. Each one of them emphasises and explains certain aspects of Lepcha culture and religion. The interconnected but sometimes contradicting storylines of the Lásó múng story link various important myths and rituals and explain time, space, as well as core concepts of social and religious organisation among the Lepcha of Sikkim and Kalimpong.

BIBLIOGRAPHY

- Blackburn, Stuart. 2008. *Himalayan Tribal Tales. Oral Tradition and Culture in the Apatani Valley*. Leiden, Boston: Brill.
- Beauvoir Stocks, C. de. 1975 [1925]. *Sikkim: Customs and Folk-lore*. Delhi: Cosmo Publications. First pub.: 1925. *Folklore and Customs of the Lap-chas of Sikkim. Journal and proceedings of the Asiatic Society of Bengal new series* 21, 325-505.
- Chakrabarty, P.B. 1985. *Folklore of the Lepchas (Rong-kup) of Sikkim*. Sen, S. (ed.). *Folklore in the North-East India*. New Delhi: Omsons Publications, 210-217.
- Foning, Arthur R. 1987. *Lepcha, My Vanishing Tribe*. New Delhi: Sterling.
- Gorer, Geoffrey. 1996 [1938]. *Lepchas of Sikkim*. New Delhi: Gyan Publishing House. First published: 1938. *Himalayan Village. An Account of the Lepchas of Sikkim*. London: M. Joseph Ltd.

- Gurung, M.M. and R.P. Lama. 2004. *Sikkim Study Series. Culture* (Part I), Vol. III. Mahendra P. Lama (ed.). Gangtok: Information and Public Relations Department.
- Gurung, M.M. and R.P. Lama. 2005. *Sikkim Study Series. Culture* (Part I), Vol. III. Mahendra P. Lama (ed.). Gangtok: Information and Public Relations Department: 107-135, revised by the Sikkim Lepcha Association (Renjyong Mutanchi Rong Tarzum, RMRT), unpublished document.
- Jest, M. Corneille. 1960. Religious Belief of the Lepcha in the Kalimpong District (West Bengal). *Journal of the Royal Asiatic Society*, 124-134.
- Kotturan, George. 1989 [1976]. *Folk Tales of Sikkim*. New Delhi: Sterling.
- Mackean, W. 1920. *Sikkim. Encyclopaedia of Religion and Ethics, Vol. 11* (Ed. J. Hastings).
- Morris, J. 1938. *Living with Lepchas. A Book about the Sikkim Himalayas*. London: Heinemann.
- Plaisier, Heleen. (forthcoming 2010). Tales of Lepcha ci, the traditional medicine for lightheartedness. Proceedings of the Golden Jubilee Conference of the Namgyal Institute of Tibetology, 1-5 October 2008, Gangtok, *Buddhist Himalayas: Studies in Religion, History and Culture*. Alex McKay and Balikci-Denjongpa, A. (eds).
- Risley, Herbert Hope. 1972. *The Gazetteer of Sikkim*. New Delhi: Bibliotheca Himalayica. First published in 1894.
- Siiger, Halfdan. 1967. *The Lepchas. Culture and Religion of a Himalayan People. Part I. Results of Anthropological Field Work in Sikkim, Kalimpong, and Git*. Publications of the National Museum. Ethnographical Series, XI: 1.
- Siiger, Halfdan. 1972. A Himalayan Goddess of Procreation. From the Lepchas of Sikkim. *Ex Orbe Religionum, Studia Geo Widengren, Pars altera, Leiden*, 236-245.
- Siiger, Halfdan. 1975. The Gods of the Lepchas of Sikkim. *Proceedings of the XIIIth International Congress of the International Association for the History of Religions 1970. Studies in the History of Religions*. (Supplements to Numen) XXXI, Leiden, pp. 298-304.
- Simick, P.T. 2001. *Rongkup Lungten. Ahbong chyokung sung*. Kalimpong: Kaycees Swit Print.
- Sprigg, Richard Keith. 1982. The Lepcha language and three hundred years of Tibetan influence in Sikkim. *Journal of the Asiatic Society*, (Calcutta) 24, 16-31.
- Tamsang, Khárpú (K.P.). 1998 [1983]. *The Unknown and Untold Reality about the Lepchas*. Kalimpong: Lyangsong Tamsang.
- Tamsang, Lyangsong. 2008. *Lepcha Folklore and Folksongs*. Kolkata: Sahitya Akademi.
- Tamsang, Sonam Tshering. 1999. འཕུལ་ལྷོ་མེད་ཀྱི་སྐྱེ་བའི་ལོ་རྒྱུས། [Azorbúngthíng and Nyúliknyúsóng mun] translated by Lyangsong Tamsang. Nyolik-Nyosong Mun, Azaor Boongthing, and Tamsang Thing. *King Gaeboo Achyok Birth Anniversary*: 29-35.

Newspaper articles

- Lepcha, Karma Loday. 1999. Namsung – the Lepcha festival. *Sikkim Express* 53, 12-18.12.1999, p. 3.
- Lepcha, Tom Tshering. 2004. Namsong. The festival of Lepchas. *Sikkim Express* 285, 10.12.2004, p.3.

Lepcha, Tom Tshering. 2003. Namsong: the festival of Lepchas. *Sikkim Express* 213, 20.12.2003, p. 3

Lepcha namthar

Nyu-lik Nyusong. 1992. Translation. Kalimpong: Mu-Tan-Chi Rong Shezoom.

Dictionaries

Tamsang, Khárpú (K.P.). 1980. *The Lepcha-English Encyclopedic Dictionary*. Kalimpong: Mayel Clymit Tamsang.

Tamsang, Norbu Tshering. 2005. *New Lepcha-English-Nepali Dictionary*. Gangtok: Lepcha Language Development Organisation.

S. MAHINDA THERO: THE SIKKIMESE
WHO GAVE LANKANS THEIR FREEDOM SONG¹

PEMA WANGCHUK DORJEE
Gangtok

Poems penned by S. Mahinda² are celebrated to this day as Freedom Songs³ in the island nation of Sri Lanka. Lankan historians are unanimous in endorsing these verses as having infused the Lankan freedom struggle of the late 1930's through to the 1940's, with the courage, strength and impetus required by the movement to inspire nationalism among the people and wrest freedom from British colonial rule. The man himself remains an enigma: a monk who engaged in the Sri Lankan freedom struggle—but not as a politician as is common there—and at a more community and social level which is rare anywhere in the world. He spoke of national pride and responsibility with such conviction and mass appeal that even the increasingly chauvinistic present-day politics of Sri Lanka tend to invoke his poems as political slogans. But S. Mahinda was not a Sri Lankan by birth, he was of Sikkim extract, a young lad who left home in the Himalayas when he was 12 and achieved iconic status in a country beyond India's southernmost tip.

Childhood

Recognised in Sri Lanka as 'Tibet Jathika S. Mahinda Thero,'⁴ he was born Pemba Thondup (more commonly known Sarki Tshering) in 1901 into the Shalngo family of Sikkim which traces its ancestry back to Khye Bumsa's grandson Guru Tashi to whom even the royal family of Sikkim traces its lineage.

¹ This article would not have been possible without the felicity with which Dr. T.R. Gyatso of Gangtok shared information on his granduncle S. Mahinda collected by his family over the years. Thank you.

² Although S. Mahinda was born Pemba Thondup and was also known as Sarki Tshering, this article refers to him throughout as S. Mahinda because that is the name he took and also to avoid confusion.

³ S. Mahinda's collection of poems invoking Lankan nationalism is famous as 'Nidhase Dahana' (mantram of independence).

⁴ 'Tibet Jathika' is probably a signifier of S. Mahinda's Tibetan ethnicity and the 'S' in his name is for Sikkim. Sri Lankan sources refer to him unanimously as Sikkim Mahinda.

S. Mahinda belonged to a generation of siblings who definitely had a difficult life, but still managed to seek destinies which remain unrivalled. His eldest brother from his father, Shalngo Nimpenjo's first marriage, was Kazi Dawa Samdup, 34 years his elder, and a celebrated translator of Tibetan scripts. From the second marriage were born three sons and a daughter, family records reveal. Sarki Tshering [S. Mahinda] was the middle son, his elder brother, Phurba Dhondup preceded him to Sri Lanka to study Theravada Buddhism and is still remembered there as Sikkim Punnaji. The youngest, Bhyapo, sought a completely diverse career—he changed his name to sound more Gorkha and joined the British Army during the First World War. He died in action in Mesopotamia.

While Pempa Thondup might have been the name given to S. Mahinda by religious elders on birth, he is recorded in most transactions of the time, and in the family records, as Sarki Tshering.

Not much is known about the early life of the siblings, but it is reasonably well established that they were orphaned young. Records put together by the family suggest that the younger siblings were brought up by relatives, but no specifics are readily at hand on their early upbringing.

Some Sri Lankan sources, specially the more celebratory treatises to S. Mahinda, mention that his father was the head monk of the Bhutia Busty Monastery in Darjeeling. This remains unsubstantiated, but subsequent Sri Lankan references tease out details which suggest that S. Mahinda's family must have been associated with the monastery at Ging in Darjeeling instead. These narratives of S. Mahinda's early life contend that his father was a monk driven to despair when his monastery was moved away from its original location in Darjeeling⁵ on the complaint of British residents, specially the nearby church, that the 'noise' of prayers at the monastery disturbed the 'tranquillity' of the area. This was the reason why the Sangchen Thong Delling Monastery is said to have been relocated to Ging in 1879.⁶ More commonly known as the Ging Monastery, this is a branch of the Pemayangtse Monastery, and since the Shalngo family shares its bloodline with the royal family of Sikkim, they would have been more closely associated with the Ging

⁵ Where the Gorkha Rangmanch at the end of Mall, below St Andrew's Church, stands now in Darjeeling.

⁶ This is when the new site was allotted to the monastery for relocation. Some sources mention that the monastery itself was completed only in 1898.

Monastery.⁷ This, incidentally, is also the area where Kazi Dawa Samdup grew up. As for the Sri Lankan invocation of this episode, one must bear in mind that the Lankan freedom struggle was essentially mounted as a confrontation to the Christian missionary work underway in the island; the chance to flesh out a Buddhist-Christian conflict in faraway Darjeeling in the life of the most celebrated national hero would be too tempting to pass up, especially since most of the write-ups on S. Mahinda even in Sri Lankan mainstream media continue to be written by Theravada monks.

By the time S. Mahinda was orphaned, his eldest brother, Kazi Dawa Samdup, had already served a rewarding career with the British India administration and was in Sikkim as Headmaster of the Sikkim State Bhutia Boarding School in Gangtok, a charge he took over in 1905. The school itself was opened on 16 May 1906 with 16 boys (*History of Sikkim* 1908).⁸ S. Mahinda, barely four or five years old at the time, would have been younger than the regular school-joining age of the time, but his elder brother must have been part of what the *History of Sikkim* introduces as the “nucleus of the school.” The school progressed well under Kazi Dawa Samdup and the future king of Sikkim, Tashi Namgyal, was also enrolled there a few years later. This could have coincided with when S. Mahinda came of school-going age. This mention is included here because one of the names that many Sri Lankan students continue to associate as S. Mahinda’s ‘Sikkimese’ name is—Tashi Namgyal, recorded in all Sri Lankan text books as ‘SK Tasilmgyal!’⁹

A recently published Sinhala book on S. Mahinda’s childhood conjectures an interesting explanation for this confusion:

It [the Sikkim State Bhutia Boarding School] was no doubt an elite school as royalty itself had been admitted to it. The prince’s name was S.K. Thashinamgapal and Ven. Mahinda, his robes no obstacle to play his pranks, had used this name as a pseudonym here. When Ven. Kamalsiri Thera had inquired in Sikkim as to a person who carried this

⁷ While the monastery at Ging is a branch of the Pemayangtse Monastery of West Sikkim and belongs to the Nyingmapa school of Buddhism, the ‘Bhutia Busty Monastery’ belongs to the Kagyu lineage and comes under the Phodong Monastery of North Sikkim.

⁸ The *History of Sikkim* (1908) by Chogyal Thutob Namgyal and Maharani Yishey Dolma, translated by Kazi Dausamdub. Unpublished typescript.

⁹ An obvious corruption of Sikkim Kumar Tashi Namgyal. Although he would become king in 1914, till then Tashi Namgyal was only a prince. At the time when he was enrolled into the Bhutia Boarding School, Sidkeong Tulku was the Crown Prince of Sikkim.

name the people there had laughed and said that was the name of the last king of Sikkim.¹⁰

A biography of S. Mahinda [in Sinhalese], released on his death anniversary on 16 March, 2009, mentions that S. Mahinda and ‘Sikkim Kumar’ Tashi Namgyal were friends at school. Unfortunately, there are no local references on this friendship, but it can be reasonably surmised that since they joined the Bhutia Boarding School at around the same time, even though Tashi Namgyal was at least nine years his senior, they would also have been friends. This is interesting because, family records also suggest that when S. Mahinda returned to Sikkim in 1920, by when Tashi Namgyal was king, he was offered appointment here as a Tibetan Teacher. S. Mahinda did not take up the offer and returned the same year to Sri Lanka.

To Ceylon

Unfortunately, there is not much literature available on Mahayana Sikkim’s interactions with the Hinayana form of Buddhism through Sikkim or the Sikkim-Sri Lanka connection, even though it was obviously accidental and through secondary sources and indirect experiences. There was however substantial exchange in the first decade-and-a-half of the twentieth century and it was through this connection that S. Mahinda discovered Ceylon and the Theravada form of Buddhism which was in stark contrast to the Mahayana Buddhism that his eldest brother was a respected exponent on.

Sometime in 1913-14, three boys from Sikkim took the train from Darjeeling to Kolkata and then a steamer to Ceylon. Records put together by the Cultural Affairs & Heritage Department of the State Government of Sikkim suggest that Sarki Tshering took this journey along with his elder brother Phurba Dhondup and another youth from Pendam village in East Sikkim, Tempa Rinzing Lepcha. The same record mentions that they were chaperoned to Ceylon by Reverend Kali Kumar.

But why was Sikkim sending students to study Theravada Buddhism and Pali in Ceylon?

As mentioned, there are only secondary sources available to explain this, and even these make only passing references. Coming under British India domination as a Protectorate State in 1861, by the turn of the century, and especially after the Younghusband Mission to Tibet in

¹⁰ Translation included in “Ven. Tibet S. Mahinda’s childhood,” by Padma Edirisinghe, published in Daily News, Sri Lanka, 20 May, 2009.

1904, Sikkim offered convenient access to Western Buddhist scholars. Darjeeling had already developed as a popular tourist destination and offered an agreeable stopover for Hinayana scholars researching in Burma and travelling onwards to Ceylon by way of Calcutta. Also, the Crown Prince Sidkeong Namgyal, who had received a reasonably well arranged Western education and was well travelled, was experimenting with reforms in Sikkim. By 1912, he was already officially in charge of education and ecclesiastical affairs, and already mooting monastic reforms. Many western travellers who came by Sikkim and met him have remarked how he was keen to reform the manner in which Buddhism was pursued in Sikkim. Even Sri Lankan sources mention that S. Mahinda was part of an experiment to groom Sikkimese youth in the Hinayana form of Buddhism so that they could return and adapt its stricter codes to Sikkim.

The *History of Sikkim* records that among the dignitaries present for the inauguration of the Bhutia Boarding School in 1906 was a “Buddhist scholar named Dharmananda (Budhopasak).” This must be Acharya Dharmananda Damodar Kosambi, a Goan who had studied Pali in Ceylon, was an ordained Theravada monk and was in neighbouring Darjeeling in 1906. He would go on to become more famous as the scholar under whose influence Dr. BR Ambedkar selected Buddhism when he decided to change his religion. Interestingly, Dharmananda was also friends with a German Bhikku, Nyanatiloka Mahathera,¹¹ an acquaintance he made while studying Buddhist texts in Burma where Nyanatiloka was studying to become a monk.

This link perhaps explains why upon their arrival in Ceylon in 1914, S. Mahinda and his brother were admitted to the Island Hermitage¹² started by Nyanatiloka in 1911. Exact records, as mentioned, have remained difficult to source, but the 1929 edition of *The Buddhist Annual of Ceylon*, makes a very interesting comment while introducing the Island Hermitage.¹³ An extract from this article reads: “This picturesque little island in the midst of the palm-bordered Ratgama Lake... is the seat of a little band of European and Asiatic Buddhist monks under the leadership of Ven. Nyanatiloka Thera.”

¹¹ Nyanatiloka Mahathera (February 19, 1878, Wiesbaden, Germany—May 28, 1957, Colombo, Ceylon), born, Anton Gueth, was the first non-British European in modern times to become a Buddhist monk.

¹² Located in midst of the palm-bordered Ratgama Lake near Dodanduwa in the Galle district of southern Sri Lanka.

¹³ *The Buddhist Annual of Ceylon*, Vol. 3, No. 3; 2473/ 1929, p.189.

The 'Asiatic Buddhists' mentioned here have to be the trio from Sikkim since there are no records of the Island Hermitage having any other 'Asiatic Buddhists' in its rolls.

Family records suggest that S. Mahinda's elder brother, Phurba Dhondup [Sikkim Punnaji], preceded him to Ceylon and that S. Mahinda volunteered to follow him there when a new opening was announced. One of the brothers arriving ahead also explains frequent references in Sri Lankan sources of how the brothers helped set up the Island Hermitage. If this had indeed been the case, then it also explains the conflicting dates in circulation for S. Mahinda's arrival in Ceylon which shift between 1912 and 1914. It is probable that Phurba Dhondup arrived in 1912 and S. Mahinda followed in 1914.

Through the war years

The timing of S. Mahinda's arrival in Ceylon was however very unfortunate. No sooner had he arrived there that the First World War broke out. German monks in Sri Lanka were first kept under surveillance at the Island Hermitage itself and then incarcerated at the Diyatalawa Army Camp.¹⁴ Nyanatiloka was subsequently shipped away to a prison camp in Australia, thence to China, repatriated to Germany and allowed back to Ceylon only a decade later in 1926.

How the young S. Mahinda and his brother managed to get through this traumatic phase remains only vaguely known. Some Sri Lankan sources record that they were interned along with Nyanatiloka at Diyatalawa. It is possible that when the German monk was being prepared for further internment in Australia, the British authorities realised that citizens of a Protectorate State [Sikkim] posed no threat and released S. Mahinda and his brother.

Sri Lankan sources also quote archival records from Sikkim as confirming that S. Mahinda received an annual stipend of Rs. 6 while he was studying in Ceylon. Even a century ago, this would have hardly have been enough to get by on and how regularly this must have been sent during the war years is also open to speculation. These years must have definitely then been difficult times for the brothers. The only home they knew in Sri Lanka was the Island Hermitage, and with Nyanatiloka and his European disciples sent away, the two brothers would have been left disoriented and without patrons. All this, even

¹⁴ Diyatalawa is a garrison town in the central highlands of Sri Lanka, in the Badulla District of Uva Province.

before he could settle down in an alien land with its alien culture, faith and unfamiliar language.

Into monkhood

S. Mahinda soon found himself back in Dodanduwa, in the vicinity of the Island Hermitage he was familiar with. Family sources record that he spent the war years living in a temporary shed at Dodanduwa, moving between monasteries at Matara, Hikkaduwa, Gonapinuwela and Haputale in the vicinity. These records also inform that by the time the war ended, S. Mahinda's brother had returned home, given up the robes and settled down to a lay life in Kalimpong. His youngest brother, as mentioned earlier, had been killed in action in Mesopotamia. Even the Crown Prince of Sikkim, Sidkeong Tulku, who had sponsored S. Mahinda's departure to Sri Lanka, was no more, having ruled for a brief 10 months in 1914 and died. S. Mahinda was left truly alone in Sri Lanka.

Although there are no records at hand authenticating who initiated S. Mahinda as a novice monk on his arrival in Sri Lanka, since he was based at the Island Hermitage, it must have been Nyanatiloka, which, in turn, must lead to the conclusion that he was introduced to the Theravada school of Buddhism under the Amarapura sect.¹⁵ This reference is important because S. Mahinda enjoyed the rare luxury of moving from one sect to another as he progressed in his pursuit of understanding faith and refining his religious grounding. His poetry celebrates his initial grooming as an Amarapura novice monk in that his writings always addressed the people, spoke of their plight, responsibilities and pride. None of the translations of S. Mahinda's poetry accessed at the time of writing this update reflects any subservience to the State or paeans to the powers that be; his poems were about patriotism and ideas of nationalism, but never about leaders and icons. S. Mahinda was born in a monarchy and lived under a colonial regime, both systems where celebratory tributes were often made to the 'masters' by poets. To find this characteristic replaced by a firm sensitivity towards the sentiments of the lay people in S.

¹⁵ The Amarapura Niyaka (school/sect) is a Sri Lankan monastic fraternity founded in 1800. It sources its name from the city of Amarapura, the former Burmese capital. The Amarapura Niyaka was a kind of a reform movement against the prevalent form of Buddhism in Sri Lanka at the time which had restricted ordination on caste lines. The Amarapura Niyaka opened its doors to all castes and people. It also revolutionised the social dynamics of faith in Sri Lanka in that it received patronage from the 'middle class' and not the royalty or the government.

Mahinda's poetry, convinces one that this instinct was honed by the Amarapura school of thought which, while it did not pursue power or riches, sought to play the role of the moral anchor for society.

At the close of WWI, S. Mahinda was still a Samanera,¹⁶ but as the lad grew more familiar with monasteries and the teachings accessible to him, he gravitated towards the Saraswati Mandapa Pirivena at Sailabimbaramaya near Dodanduwa. It was here that S. Mahinda was ordained as a monk under the tutelage of Ratgama Siri Culasumana.

The Theravada rules require an incumbent to be at least 20 years of age before he can be ordained as a monk. This would mean that S. Mahinda lived as Samanera at least till 1920-21. How he spent what must have been the rather confusing and displaced years between 1914 and 1920, remains unclear. The inability to access sources in Sri Lanka (most of which would be in Sinhala) leave events in S. Mahinda's life through these years rather hazy. Information collected by his descendents in Sikkim suggests that he lived and studied in Colombo with his elder brother through some of the war years. Available sources in Sri Lanka however date his arrival in Colombo and his further studies there to the years after he had received his ordination. It might be a safe guess then to suggest that S. Mahinda remained in Dodanduwa and studied at Sailabimbaramaya, where he also received his ordination and continued his studies for a while, before proceeding towards Colombo.

It also appears that before taking his vows, S. Mahinda returned to Sikkim on his only recorded visit since leaving for Sri Lanka. Records put together by the Cultural Affairs & Heritage Department of Sikkim inform that S. Mahinda returned to Sikkim in the year 1920. While here, he was offered employment by Chogyal Tashi Namgyal as a teacher at a Gangtok school, an offer he turned down and returned to Sri Lanka. It was upon his return from Sikkim to Sri Lanka, that he is believed to have taken full ordination and entered the monk body.

Sri Lankan sources highlight that his years at the Saraswati Mandapa Pirivena were of intense learning, a place where he gained proficiency in Pali, Sanskrit and Sinhala languages and acquired enviable erudition in the Buddha Dhamma. Remarkably for a non-native Sinhala speaker, he was among the most notable in his group as an orator, a skill he appears to have developed even before he discovered poetry. His being noticed among the pupils at Saraswati Mandapa Pirivena is a tribute to his scholarship because studying alongside him was a generation of Sri Lanka monks, a sizeable number

¹⁶ Novice Theravada monk.

of whom would go on to head monasteries and schools across the country and beyond in later years. Lankan sources are unanimous in revealing that it was also at this monastery that S. Mahinda discovered poetry when he came in contact with an obscure poet-monk Sri Jinaratane who resided in a hut next to S. Mahinda's.

As he continued his studies and practised his poetry, an opportunity arrived to shift to a new place. He found a mentor in Makada Dhirananda Thero and moved into his monastery in Saugatavasa on Slave Island near Colombo. Here he immersed himself into refining his grasp over Sinhala, Pali and Sanskrit and also began learning English. Some of his earliest published works in magazines and other periodicals date back to this time. He was also gaining in popularity for his religious discourses which were eagerly subscribed and much appreciated.

It was in the course of delivering such sermons that S. Mahinda found himself, sometime in mid-1930, at the Purana Rajamaha Vihara, Ratmalana, near Colombo. Among his audience on the day was the monastery's head, Dharmarama Indrajyoti Nayaka Thero, who was so impressed by the erudition of this foreigner monk that he invited him to study and reside at his monastery. Dharmarama Nayaka Thero was an icon of his times and S. Mahinda was captivated by the expanse of his learning and wisdom and accepted the offer. The same year, with Dharmarama Indrajyoti Nayaka as his main tutor, S. Mahinda took his second ordination as a monk. As his introducer to the faith (preceptor), he had Dharmananda Nayaka Thero. Interestingly, S. Mahinda's second initiation¹⁷ was under the Siyamopali Niyaka¹⁸, which, like the Amarapura Niyaka that S. Mahinda had his first ordination under, was also reform-oriented in its genesis.

This association with the two masters saw S. Mahinda bloom as a scholar and develop into a poet with a strong social involvement.

Dharmarama and Dharmananda were visionary scholars of Sanskrit and Pali and had done substantial work in translating texts from these languages into Sinhala. Dharmarama Thero is reputed to have developed scholastic traditions in Sinhala to such a refined level that he is revered to this day as the scholar who saved the language and its literature from further decay. This was a trend that S. Mahinda would sustain, and apart from his poems which make him popular among the Sri Lankan laity, the religious bodies there still refer to the substantial

¹⁷ Dated in some Sri Lankan sources as having taken place on 16 June, 1930.

¹⁸ Also known as Siam Niyaka, named after the Thai monk who introduced it to Sri Lanka in the late eighteenth century.

amount of translations he worked on. Dharmarama, and Dharmananda after him, were also heads of the Vidyalankara Pirivena in Sri Lanka. This was a chain of religious schools (open to both monks and lay persons) with a progressive attitude much beyond its times. The school encouraged experimentation with modern literary forms, and, in a marked departure from the regulated scholastics of religious schools, adopted methods of instructions which promoted creativity in literature and art—traits which perhaps encouraged S. Mahinda to write more poetry. Its syllabus included, apart from Buddhism, Pali, Sinhala and Sanskrit, also subjects like History, Archaeology, Arithmetic, English, Tamil, Geography and Psychology. The Vidyalankara Pirivena also participated in active political and social agitation and encouraged monks to get involved in social works and reform, characteristics which define S. Mahinda's poetry.

While at the Ratmalana Rajamaha Vihara, S. Mahinda devoted himself to religious studies and cleared his preliminary and middle Pracin examinations. He cleared his higher ordination within a year from the Malwatte monastery in Kandy, the monastery which along with the Asgiriya monastery there, is considered the Centre of Buddhism in Sri Lanka and are also the most important monasteries of Siyampoli sect into which S. Mahinda was now ordained. With his higher ordination, he received the title 'Wahala Naga.'

In the four years that he was based at Ratmalana Rajamaha Vihara, he also studied at the Mahabodhi College in Colombo and acquired a substantial reputation as a scholar. It was perhaps this reputation that earned him an appointment as a lecturer at the renowned Ananda College in Colombo. In continuing recognition of his erudition, he was handed the charge to teach three subjects—Pali, Buddhism, and remarkably, again, for a non-native speaker, Sinhala. When he accepted his chair at Ananda College, S. Mahinda moved back to his Slave Island monastery which was closer to the college. The Ananda College website continues to highlight to this day that S. Mahinda was one of the faculty who taught there. S. Mahinda, however, remained on the job only for two years and moved on in 1936 to Maha Bellana in Punadura to the south of Colombo, the place that would be his home for the remaining 15 years of his life.

Among the people

When S. Mahinda moved to Maha Bellana, he took up quarters in the Sri Sudharnarama Temple there. The family records mention that this monastery belonged to one of his teachers, but does not specify which.

S. Mahinda began work here by developing the temple, starting by erecting a proper boundary wall for the monastery, then raising funds to construct a new hostel for the monks, a preaching hall for the people. Then began his involvement in the welfare of the people in his immediate vicinity. The process started with S. Mahinda starting a Sunday Dhamma School at the monastery, recorded in some Sri Lanka texts as Nawalanka Dhamma School. As enrolment increased, S. Mahinda added an English School to service the local population. As his interaction with the lay people grew, so did the scale of his assistance in alleviating their travails. Soon, S. Mahinda was raising funds to setup a dispensary for free distribution of medicines among the underprivileged. This he did ingeniously by setting up a series of collection centres stretching from Maha Bellana to Colombo where people could donate medicines for onwards distribution to those who could not afford it.

These were still engagements at a very social service level, but the winds of change were already sweeping through the island and a resistance developing against British colonial rule. Within a year of his arrival in Sri Lanka, the nation witnessed its first anti-British rioting in 1915 and this must surely have left an impression on S. Mahinda especially since the movement was spearheaded by monks. By the time he arrived in Maha Bellana, the Sri Lankan freedom struggle was more organised and the presence of monk representatives in the struggle very pronounced. It was only a matter time then, that S. Mahinda found himself positioned in a more confrontationist stance against the British.

As part of his social work in the area, he brought the Temperance Movement to Punadura. The temperance movement in Sri Lanka was, like in the rest of the world, positioned against the sale and consumption of alcohol. In Sri Lanka it acquired a nationalist position because the British regime saw it as a direct confrontation—the exchequer was earning substantial revenue through excise tax. Records indicate that this movement was very successfully led by S. Mahinda in Maha Bellana.

Next came the more dramatic exhibition aimed at discouraging people from consuming beef, which again, the British establishment was seeking to promote in the area (some Sri Lankan records contend that this was to defile Buddhism and assist the Christian missionary work afoot across the island). To get his appeal across to the people, S. Mahinda arranged for a gigantic procession of oxen through town, reminding people of the life they snuffed out when they put meat on their tables and highlighting the service these animals render. This one

initiative has achieved legendary status in Sri Lankan historiography, with reference included whenever S. Mahinda is referred to in connection with more than his poetic achievements.

He also worked hard at reviving interest in and understanding of the Dhamma among the people. The Sunday School was already doing reasonably well, and then S. Mahinda brought to Maha Bellana the unique to Sri Lanka form of sermons—the Suvisi Vivarana, sermons which include a great deal of singing and dancing. These can sometimes last up to six days, but S. Mahinda played these out for an entire month, the song and dance routines sharing the stage with an exhibition of L.T.P. Manjushri's Suvisi Vivarana series of paintings.¹⁹

All this while, S. Mahinda was also producing copious amounts of translation works and revolutionary poetry.

The national poet

As mentioned earlier, S. Mahinda was in Sri Lanka through the turbulent times of two World Wars and a resurgence of the freedom struggle. The Sri Lanka freedom movement was not among the best coordinated in the early 1930's, plagued as it was with sectional, regional and ideological differences. The involvement of the lay people was still hesitant with too many distractions, from famine to wars, leaving the movement uninspired as much as in invoking Lankan pride to marshal mass support was concerned.

At around this juncture, S. Mahinda's patriotism-fuelled poetry started getting published and were soon being picked up by leaders of the freedom struggle for wider circulation of the inspiring verses. S. Mahinda's poetry consistently sought out inherent instincts of nationalism and faith and commandeered these to address the need for the people to stand up and claim their freedom.

A rough translation of one of his verses is suggestive of the tone of his writings:

¹⁹ The L.T.P. Manjushri–S. Mahinda association is very interesting one. Manjushri was a year younger than S. Mahinda and joined the Sangha, like S. Mahinda, at the age of around 13. Like S. Mahinda left for foreign shores and found his faith, so did Manjushri, who went to Shantiniketan in West Bengal to study Chinese. There he also discovered art, and like Mahinda used his poetry, Manjushri used his brush and is today recognised as the most significant modern artists of Sri Lanka. Like S. Mahinda translated, Manjushri travelled through Sri Lanka, visiting monasteries and making copies of paintings there. In many cases, Manjushri's copies are the only evidence left of the original art.

*Es Gedi Dekata Hena Gahalada Sihalune...
Ennu Idiriyata Nethahoth Nidahasak Nehe*

Oh! Sinhala folk, are your eyes too bedazzled by lightning...
That you cannot even see—unless you step up, there can be no freedom²⁰

Unfortunately, English translations of S. Mahinda's works have not been attempted yet and only snatches of his poetry can be accessed by non-Sinhala speakers. What can be ascertained though is that S. Mahinda was already an established poet when he arrived in Maha Bellena in 1936.

In 1935, when a group of young Sri Lankan poets got together for an informal meet in Colombo, they ended with a resolution to form an organisation under which to collaborate and hark in a new era of Sinhala poetry. The Colombo Kavi Samajaya (Colombo Poetry Association) was born out of this meeting and the young poets unanimously decided to have S. Mahinda as the Association's first patron; S. Mahinda accepted the offer.²¹

His powerful verses triggered unrivalled pride and patriotism among the Sri Lankans and much has been written on this aspect of S. Mahinda's contribution to the Sri Lankan nation. It is also in this role of a Patriot Poet that he receives universal celebration in the country. His statue stands on the road leading out of Ceylon railway station towards Maha Bellana and commemorative stamps have been issued by Sri Lanka to celebrate his memory. Stories from his life are included in Sri Lankan textbooks and his poems form part of the syllabus there. Every Sri Lankan student knows of S. Mahinda and most can recite his poems by heart. Many also have childhood memories of being lulled to sleep by lullabies composed by this virtual polymath. He is also credited with having developed children's literature in Sinhala and many of his rhymes are aptly the favourites of the young to this day. Even many of his patriotic poems were directly addressed to the young, like this one:

*Nidahasa Maha Muhudak ve
Ebawa Sihikota Melove
Ebawa Sihikota Melove
Yutukama Itukalayutu ve²²*

²⁰ "Ven. S. Mahinda and the Dalai Lama," published in Daily Mirror, Colombo, 16 April, 2008.

²¹ "Sixty Six Years of Sinhala Poetry," by Mervun Senaratne, Daily News, Colombo, 12 January 2002.

²² Facebook page dedicated to Tibet Jathika S. Mahinda Thera.

If the Ocean is Freedom
 Its fount is the baby in the cradle
 A child who has learned to care for the motherland
 From the affection his mother indulged in him

An interesting anecdote traced down by his family in Sikkim relates to the All Ceylon Verse Competition held at the Royal College, Colombo. The record does not mention the year, but details that S. Mahinda participated in this contest and won. He however refused to collect the cash prize set aside for the winner because it went against his monastic vows which disallowed him from partaking in material profits.

At the cost of endless repetition, one cannot help but get awed by the commitment and confidence of the teenager who volunteered to study an alien faith in an alien land back in 1914 and managed to achieve such excellence in it, that a country which is now grappling with ethnic divisions, factionalism and violence, continues to find relevance in his poetry and invokes it often to reinforce Lankan nationalism. In the most handsome recognition of the emotional thread of S. Mahinda's poetry, his verses are used equally by the right wing chauvinist politicians as well as the civil society eager to find a Lankan identity which rises beyond ethnic segregations. Activist playwrights and right-wing politicians, both fall back on the sensitivity of S. Mahinda's poetry to further their arguments. The ethnic strife in the island nation has in fact led to a rediscovery of S. Mahinda, with his death anniversary on 16 March, observed across the country by a multitude of organisations with special book releases and poetry recitals. Publishing houses announce essay-writing contests on the life and teachings of S. Mahinda at around this time of the year and several compilations get published in the subsequent months of the prize-winning contributions.

S. Mahinda's memory is important to Sri Lanka and is consciously sustained by the people themselves. When the school syllabus in Sri Lanka was reworked in the year 2000, a chapter on S. Mahinda got dropped from the class IX history text books. This led to nationwide outcry and demands to have the chapter included in the text books again. The movement succeeded and Sri Lankan students continue to read about S. Mahinda and study his poems in school.²³

National recognition had arrived for S. Mahinda during his lifetime itself when he was heralded across the country as the national poet. When he died in 1951, within a few years of Sri Lankan independence

²³ "Text book war of words in Sinhala," *The Island*, published from Colombo, 24 March 2000.

of 1948, he was accorded a state funeral and commemorative stamps have been issued in his name since.

Mahinda is often referred to as ‘Tibet Jathika S. Mahinda,’ a qualifier which marks his Tibetan ethnicity, but many take this too literally and invoke the role he played in the Sri Lankan freedom struggle to demand that the Lankan government find its backbone in condemning Chinese occupation of Tibet.²⁴ Venerable Dhammika, writing nearly a decade ago, sought for a more proactive role from the Lankan Government in supporting the Tibetan cause and shared a very interesting incident. He wrote: “Recently, the Chinese government sent a scholar to Sri Lanka to research into Mahinda’s life and writings with the purpose of highlighting the supposed ‘Chinese’ contribution to Sinhalese literature. When it was discovered that Mahinda was born in Sikkim, not Tibet, the scheme was quietly dropped.”²⁵

In one of the rare celebrations of the Dalai Lama’s birthday in Sri Lanka [on 06 July, 2009], the special programmes organised by the Friends of Tibet [Sri Lanka], included recitals of S. Mahinda’s poems.

S. Mahinda was many things and meant many different things to the Lankans, but his most lasting contribution to the nation’s memory was a sense of pride. His name continues to invoke passionate reactions from the Lankans and it was through one such display that Dr T.R. Gyatso, who shared information put together by his family to make this article possible, learned of what a ‘great man’ one of his grandfather’s brothers had become. Dr. Gyatso is the grandson of S. Mahinda’s eldest brother Kazi Dawa Samdup. He recollects that it was during a World Health Organisation meeting in Jakarta in 1981 that he ran into some monks from Sri Lanka. While talking to them on the sidelines of the meeting, he mentioned to them that one of his grand uncles had gone to Sri Lanka and become a monk there. When he told them that his granduncle was S. Mahinda, the group of stoic monks broke into a gaggle of excited Sri Lankans. They posed for photographs with him, took his autograph and address and insisted on treating him to dinner. It was through this reaction that the celebrity status of a granduncle who had left home in Sikkim and settled down in Sri Lanka sank in.

²⁴ For example, “Ven. S. Mahinda and the Dalai Lama,” published in Daily Mirror, Colombo, 16 April, 2008. The theme of this article was to remind people that S. Mahinda came from the same country as the Dalai Lama has been forced to flee from by China.

²⁵ “Tibet and Sri Lanka,” by Ven. Dhammika, *The Middle Way*, May 2001.

Nearly a century since Sarki Tshering left Sikkim for Sri Lanka to become S. Mahinda, the creator of rousing verses of Sri Lankan nationalism, he remains an enigmatic figure; the story of life known only in snatches. This narrative is superficial at best, but not for want of interest or effort, but because of the absence of note-sharing between sources in S. Mahinda's place of birth and the land where he inspired a freedom struggle. Hopefully, this is a start towards undertaking a deeper enquiry into understanding how a 13 year old Sarki Tshering of Sikkim grew into the much venerated Tibet Jathika S. Mahinda Thero of Sri Lanka.

A BRIEF BIOGRAPHY OF KAZI DAWA SAMDUP (1868-1922)

DASHO P.W. SAMDUP¹
Thimpu

Kazi Dawa Samdup was born to Shalngo Nimpenjo—also spelt Nim Paljor of the Guru Tashi clan²—on 17th June, 1868 in Sikkim. On the death of his mother, his father remarried, begetting three sons and two daughters from the second wife.

Among Kazi Dawa Samdup's siblings, the youngest brother Sarki Tshering—also known as Pemba Thendup according to some sources—acquired equal fame and honour in Sri Lanka as Reverend S. Mahinda Thero. In recognition of his contribution towards the propagation of Buddhism, and the development of Pali and Sinhala languages, the Sri Lankan government erected a statue in his name and also issued commemorative postage stamps in his memory. Pemba Thendup was mainly recognised as a poet monk, whose poems and songs inspired the Sri Lankan people during their independence movement. Considered as a national hero, his patriotic and devotional songs are used in school textbooks to instill a national feeling.

Kazi Dawa Samdup's early education began at the age of four learning the Tibetan script from his grandfather. Thereafter, in 1874,³ he was admitted as a boarder in the Bhutia Boarding School in Darjeeling—later Darjeeling Government High School—where he

¹ This short biography was written by Dasho (Dr) P.W. Samdup, grandson of Kazi Dawa Samdup, who served as one of the earliest doctors in Bhutan and now leads a retired life in Thimpu, Bhutan. He can be contacted at GPO Box no 377, Thimphu, Bhutan, telephone numbers +975 2 323352/+975 17669837, email drsamdup61@hotmail.com. All the information in this biography is based upon a write-up compiled by his father, the late Mr T.T. Samdup, son of Kazi Dawa Samdup, family owned records and diaries maintained by Kazi Dawa Samdup himself, various publications of his work and accounts of Kazi Dawa Samdup's life as told by his students, some of whom include distinguished and eminent personalities such as Kazi T.D. Densapa, Secretary General, Development Ministry, Royal Government of Bhutan (first high level deputation from the Government of India to Bhutan), and Lama Karma Samdhen Paul, lecturer of Tibetan at Calcutta University and later lecturer of Tibetan at Government College, Darjeeling, where Dr P.W. Samdup had the privilege of being a student.

² [Editor's note: the Guru Tashi clan is one of the four founding clans of Sikkim to which the Namgyal dynasty or royal family of Sikkim belongs].

³ The year could have been 1874 or 1875.

impressed the headmaster Rai Bahadur Sarat Chandra Das. The headmaster was very pleased with the progress of his studies. His Tibetan teacher was Rai Bahadur Ugyen Gyatso, a lama originally from the Pemayangtse monastery in West Sikkim. Kazi Dawa Samdup was a very bright scholar and received a silver medal for his proficiency in the English language.

After completing school, he joined the service of British India as Chief Interpreter to the Commissioner of Raj Shahi Division and was posted at the Buxar Duar in Bhutan. During his stay in Bhutan, he came across a learned lama, Lopen Tshampa Norbu of Punakha. Kazi Dawa Samdup took a fascination to the Lopen who possessed vast mystical knowledge and led a strict ascetic life. He became a pupil of the great Lopen and received mystic initiations from him. He was so impressed by him that he almost renounced his worldly life to lead the ascetic life of a Buddhist monk. Kazi Dawa Samdup's father who was very old by then did not allow his eldest son to lead the life of an ascetic. Sometime later his father died and the responsibility of looking after his stepmother, three younger brothers and two younger sisters fell on his shoulders.

At the time, the ninth Maharaja of Sikkim Sir Thutob Namgyal was looking for a suitable headmaster, who could teach both Tibetan and English, for the state Bhutia Boarding School for boys at Gangtok. Kazi Dawa Samdup was proposed for this post by Crown Prince Sidkeong Tulku. Accordingly, his service was lent to the Sikkim Durbar in 1905 as the headmaster of the state Bhutia Boarding School at Gangtok. In addition to ably running his school, he undertook the compilation and translation of the Sikkim Gazette for Maharaja Sir Thutob Namgyal in 1911.⁴

His proficiency in the English and Tibetan languages often led to his services being borrowed for important occasions. In 1905, he accompanied the Maharaja of Sikkim to Calcutta on the occasion of the visit of the British Heir Apparent and his consort, the Prince and Princess of Wales. In 1910, his services were lent to the British Political Officer Sir Charles Bell to act as interpreter and translator during HH the 13th Dalai Lama's visit to India. In December 1911, Kazi Dawa Samdup accompanied the Maharaja of Sikkim to Delhi for the coronation Durbar of King-Emperor Edward V. In 1914, his services were utilised once again by the British Political Officer Sir

⁴ [Editor's note: the author is most probably referring to the unpublished *History of Sikkim* compiled by Maharaja Sir Thutob Namgyal and Maharani Jeshay Dolma of Sikkim in 1908].

Charles Bell during the historic Simla Convention on the Indo-Tibet Border signed between India, Tibet and China.

Kazi Dawa Samdup wanted to propagate Tibetan Buddhism to the world, and especially to the English-speaking world. This required extensive translation of difficult Buddhist and tantric texts into English and heavy publication expenses, which he could not afford. His opportunity came when the famed orientalist Dr W.Y. Evans-Wentz came to see him at Gangtok. Dr Evans-Wentz was prepared to edit and bear the publication costs. Kazi Dawa Samdup set about translating difficult Tibetan texts into English ensuring that the contents were simple enough for ordinary laymen to understand. Some of the important translations rendered by him are:

1. The Tibetan Book of the Dead⁵
2. Tibet's Great Yogi Milarepa⁶
3. Tibetan Yoga and Secret Doctrines⁷
4. Tibetan Book of the Great Liberation⁸
5. The History of Sikkim, 1908

In 1919, Kazi Dawa Samdup edited the English translation and the Tibetan text of the Shrichakrasambhara Tantra, which was published by Sir John Woodroffe as Volume 7 of the Tantrik Texts.⁹ Sir Woodroffe writes about Kazi Dawa Samdup: "These and other appointments

⁵ *The Tibetan book of the dead; or, The after-death experiences on the Bardo plane, according to Lāma Kazi Dawa-Samdup's English rendering, with foreword by Sir John Woodroffe, London, Oxford University Press, H. Milford, 1927.*

⁶ Evans-Wentz, W. Y., ed. *Tibet's Great Yogi, Milarepa : A Biography from the Tibetan; Being the Jetsün-Kahbum or Biographical History of Jetsün-Milarepa According to the Late Lama Kazi Dawa-Samdup's English Rendering.* London: Oxford University Press, 1928.

⁷ Evans-Wentz, W. Y., ed. *Tibetan Yoga and Secret Doctrines, or, Seven Books of Wisdom of the Great Path, According to the Late Lama Kazi Dawa-Samdup's English Rendering.* London: Oxford University Press, 1935.

⁸ *The Tibetan book of the great liberation; or, the method of realizing nirvana through knowing the mind, preceded by an epitome of Padma-Sambhava's biography and followed by Guru Phadampa Sangay's teachings. According to English renderings by Sardar Bahādur S. W. Laden La and by the Lāmas Karma Sumdhon Paul, Lobzang Mingyur Dorje, and Kazi Dawa-Samdup.* Introductions, annotations, and editing by W. Y. Evans-Wentz. With psychological commentary by C.G. Jung. London, New York, Oxford University Press, 1954.

⁹ *Shrichakrasambhara Tantra: A Buddhist Tantra, Edited Kazi Dawa-Samdup.* Edited by John Woodroffe. Translated by Kazi Dawa-Samdup. Tantrik Texts V. 7. London: Luzac & Co., 1919.

which the translator held and to which Dr Evans-Wentz had referred, sufficiently establish this competency both in Tibetan and English. He had also, I may add, some knowledge of Sanskrit, which I found of much use in discussing with him the meaning of terms used in Tibetan Buddhist doctrine and rituals.” In addition to these major translations, he also contributed short articles for the Asiatic Society of Calcutta.

During the same year, Sir Asutosh Mukerjee, the then Vice Chancellor, appointed Kazi Dawa Samdup as Professor of Tibetan at Calcutta University where he compiled and published his English-Tibetan dictionary in 1919. The dictionary was and still remains unique because it also contains meanings in the Sikkimese and Dzongkha languages.

Kazi Dawa Samdup, being a man from the hills, could not adjust to the hot and humid climate of Calcutta. His health rapidly deteriorated till he breathed his last on 22nd March 1922 at the young age of 54 at Calcutta General Hospital. Kazi Dawa Samdup’s friend Profulla Shankar Sen writes in his obituary, “Kazi Dawa Samdup was an early riser, at 4 am he used to be out of bed. After his morning ritual of prayers, he would set about his day’s task. A hard worker who worked himself to early death in the hot climate of Calcutta. He was simple in his bearing, enjoyed long discourse with learned people.”

In addition to being an intellectual, Kazi Dawa Samdup was also a competent artist, well adept in both water and oil colour painting. He left behind some portrait paintings, including a self-portrait and religious paintings.

At his death, Kazi Dawa Samdup left behind his wife, eight year old daughter and ten year old son. The son, late T.T. Samdup, led a retired life in Kalimpong while his late sister Dorji Budar, wife of late Shap Kalon Kazi Daw Gyatso, resided at Bikstang, West Sikkim.

Kazi Dawa Samdup was a pioneer through whose efforts secrets of the Tibetan Buddhist doctrine were unlocked for the first time to the Western World.

CONFERENCE REPORT: GOLDEN JUBILEE CONFERENCE
OF THE NAMGYAL INSTITUTE OF TIBETOLOGY,
GANGTOK, SIKKIM, 1-5 OCTOBER 2008

JOHN BRAY

International Association for Ladakh Studies

The Namgyal Institute of Tibetology was founded 50 years ago by a distinguished group of scholars as well as political and religious leaders. H.H. the Dalai Lama laid the foundation stone. Indian Prime Minister Jawarharlal Nehru gave an address at the inauguration ceremony. The Founder President was then Sikkim Maharajkumar Palden Thondup Namgyal, and the 24 founder members included such luminaries as NK Rustomji, Jamyang Khyentse Rimpoche, the English Buddhist monk Sangharakshita, Babu Tharchin the Christian leader and newspaper publisher from Kalimpong, and the Indian academic NC Sinha. Since then, the Institute has built up one of the most comprehensive libraries of Tibetan literature in the world, established a museum, and brought out a series of valuable publications, including its biannual journal, the *Bulletin of Tibetology*. This Golden Jubilee conference therefore had much to celebrate.

The Opening Ceremony included speeches by Shri Balmiki Prasad Singh, the Governor of Sikkim; Chief Minister Dr Chamling; Senior Presiding Scholar Gene Smith, formerly of the US Library of Congress; Lama Chosphe Zotpa of the National Commission for Minorities; and Ashok Sinha, the son of former institute director NC Sinha. Lama Zotpa emphasised the importance of promoting the common cultural and linguistic heritage of communities in the Himalayan region from Ladakh in the west to Arunachal Pradesh in the east.

The overall theme of the conference was “Buddhist Himalaya: Studies in Religion, History and Culture”, and it attracted more than 60 papers as well as a series of workshops on topics such as thangka preservation, textbooks in minority languages and—with an eye to younger scholars—academic conventions on matters such as footnote citations. The participants included senior Sikkimese scholars as well as visitors from other parts of India, Nepal and Bhutan together with Austria, France, Germany Japan, the Netherlands, New Zealand, Poland, Switzerland, the UK and the US.

The conference theme was intended to be broad, in accordance with the Institute's Tibetological traditions. However, as explained by Research Coordinator Dr Anna Balikci-Denjongpa, there has recently been a greater focus on the study of Sikkim itself. She herself offered a review of the challenges and opportunities of anthropological research on the region.

Sikkim was represented by scholars such as the late Tashi Topden, who gave a poignant presentation on the "History and loss of Sikkimese culture". Among others, Khenpo Lha Tsering spoke on the establishment of the Nyingma tradition. S.D. Tsering discussed the religious aspects of the recent socio-economic census of Sikkim conducted by the Department of Economic Statistics, Monitoring and Evaluation; and Pema Wangchuk analysed the early British construction of Sikkimese history.

Notable contributions on Sikkim by foreign scholars included a paper by Saul Mullard of Oxford University, who has been carrying out groundbreaking documentary research on the formation of the Sikkimese state in the 17th century. Elliot Sperling discussed the Tangut/Mi-nyag element in the lineage of the Sikkim Chogyal, while Isrun Engelhardt reviewed the photographs and findings of the 1938 Ernst Schäfer expedition to Sikkim and Tibet. George van Driem explained the history of the Limbu script.

Ranging further afield, Karma Phuntso from Bhutan gave a stimulating overview of "Tibetan Buddhist book culture", while Tsewang Jigme Tsarong discussed the Buddhist system of medicine. Peter Schwieger analysed the expansion of the power of the 5th Dalai Lama in east and south-east Tibet in the 17th century, and Toni Huber analysed Tibetan political and economic interests in the far eastern Himalaya in the first half of the 20th century.

Altogether, the conference was distinguished both for its wide geographical range and its interdisciplinary character. Paper topics extended from Bhutan, Arunachal Pradesh and Kham in the east to Ladakh in the west, and covered art, linguistics, history, anthropology, 'sacred space', and the environment. It will undoubtedly prove a stimulus to further research, both in Sikkim itself, and in the wider Himalayan region.

Associated conference activities included an excursion to Rumtek monastery, as well as dinners hosted by the Governor at Raj Bhavan (the residence during British times of the Political Officer Sikkim) and by the Sikkim Culture Minister. The Institute also organised exhibitions of photographs illustrating the history of the Namgyal dynasty, and

Sikkim's relations with Bhutan. In the best Sikkimese tradition, the conference was notable for its warm hospitality, and the opportunities for fruitful contact between a wide range of local and international scholars. The participants owe an enormous debt to Institute Director Tashi Densapa, and to all their hosts in Sikkim.

Three volumes of conference papers will be published in due course under the editorship of Alex McKay (the academic convenor), Anna Balikci-Denjongpa and Tashi Tsering of the Amnye Machen Institute in Dharamasala.

RECENT ACQUISITIONS TO THE NAMGYAL INSTITUTE OF
TIBETOLOGY HOLDINGS AND FUTURE PUBLICATIONS¹

SAUL MULLARD

*Namgyal Institute of Tibetology**Introduction*

The last twelve months have seen a number of significant changes at the Namgyal Institute of Tibetology (NIT). Not least amongst which was the celebration of its Golden Jubilee, marked with an international conference. In addition to this, NIT has also recently acquired two collections: The Sikkimese Palace Archives and a selection of manuscripts from Ri nag (Renock). Both of these collections offer an interesting insight into Sikkimese history and political organisation, something the current author is keen to explore and study in more depth. The acquisition of these collections has enhanced the variety of the holdings of NIT.

NIT has also recently invested in a number of technological tools which can be used to preserve these collections and allow, over time, public access to these collections through digital technology. It is the area of digitisation that NIT has invested heavily, with three digital scanners capable of scanning documents to museum and international archival standards. Plans are also in progress to create a hermetically sealed, climate controlled vault to hold rare manuscripts, and images which are susceptible to the variations (such as high levels of humidity) of the Sikkimese climate. It will be a number of years before this vault will be in operation but in the meantime a number of actions have been put in place to protect the documents from excessive damage from light and weather conditions. These actions include the purchase of a dehumidifying machine, the use of covered ventilated storage racks (to allow the flow of dry air through the collections and prevent light damage to the materials).

¹ The author would like to express his gratitude to the Director of NIT, Tashi Densapa for allowing me access to the Palace Archive and giving me permission to work on this material. This research project would not have been possible without the generous support of the Leverhulme Trust who have provided the author with research funds for two years of post-doctoral work.

The Sikkimese Palace Archives

The archives of the Sikkimese Royal Palace were recently transferred to the custodianship of the Namgyal Institute of Tibetology, having previously been held by the Art and Cultural Trust of Sikkim. This collection, of legal documents, letters and internal and international agreements, is a rare source of information for the study of Sikkimese, Tibetan, Bhutanese and British Indian history. This collection covers a range of historical periods, from the time of early Sikkimese state formation in the mid seventeenth century (the earliest document is dated 1663), the Sikkim-Gorkha war of the 1780s and 1790s, the British period c.1817-1947, to the period prior to the merger of Sikkim with India. The collection also contains documents written in a number of different languages including Tibetan (the majority of material), Lepcha, English, Nepali and Mandarin. Similarly they range in format, from letters, treaties, decrees and land grants to personal note books, receipts and private letters.

The complete archives also include photographs and films. Some of these photographs are copies of collections housed elsewhere, but some are personal albums including holiday snaps, providing an altogether different side of the royal family than the official photographs. The photographs and films will be added to the NIT photographic project, under the direction of Anna Balikci-Denjongpa. This project is aimed at preserving a visual record of the history and culture of Sikkim during the photographic age. By adding to this project and the literary holdings of NIT, the acquisition of the Sikkimese Royal Archives, will greatly improve the research work of NIT and contribute to our knowledge of Sikkimese history and culture. Indeed one of the key problems with conducting historical research in Sikkim in the past was the lack of accurate and authentic records; however, with the transfer of this collection this problem has been eased greatly.

In order to guide scholars through the documents in this collection the current author along with Hissey Wongchuk are compiling a catalogue of the collection. The catalogue, *Royal Records: The Sikkimese Palace Archives*, will be published in January 2010 and made available to local and international scholars. NIT is accepting pre-publication orders for this catalogue and those who are interested should contact NIT. In addition to the catalogue the entire collection of documents has now been digitised to allow future scholars access to the material without causing excessive handling of the original documents. It is anticipated that the collection will be available for consultation by

the wider academic community in 2011, following the publication of part of this collection. This second publication in the Palace Archive Project will include a selection of material from the collection, with translations and commentaries following the examples and methodology of Dieter Schuh (1978) and, more recently, Charles Ramble (2008).

Some examples from the Palace Archive

The variety of material found in this archive is astonishing, ranging from official government papers, to petitions by Sikkimese commoners regarding the excesses of the aristocracy as well as official and diplomatic correspondence with Tibet, Bhutan and British India. Whilst the official records and diplomatic letters inform the historian of Sikkim in its wider context of its geopolitical significance and the internal administration of the former country, the letters from ordinary citizens shed light on the hitherto unknown (or at least unrecognised) experiences and conditions which common people faced. With the variety of the material being such, for the first time in the study of Sikkimese history it is possible to envisage the macro political structures and their place in the international affairs of the region and the micro level of day to day existence. A number of examples may at this point enlighten the reader with regards to the importance of this collection.

The Case of the Missing Horse. In a series of documents found in the section of the collection regarding internal agreements and petitions one finds two rather interesting documents involving a trader known as Khos [Khol] chung dkar po. In the first document Khos chung dkar po is accused (and found guilty) of failing to pay for a horse he bought for the price of 10 dngul srang, he is ordered to pay the amount or face a fine of 2 gser srang. In the second document we learn that this same figure was a Tibetan trader from Khams, who once again had bought a horse from the Chogyal's horse trader, but according to the horse trader failed to pay for the horse. At first appearance it seems as if this Khos chung dkar po is nothing more than a thief, but at closer inspection of the documents we find the case a little more dubious. Reading between the lines it becomes clear that the second document was sent to the Chogyal in response to an earlier (but now lost) letter to the horse trader by the government in which they recognised a discrepancy in the accounts and enquire into the reason for this. The response of the Royal horse trader is to pass the blame on to an unknown Tibetan trader (who by virtue of being Tibetan was untraceable and outside the legal system

of Sikkim). The plot thickens when the horse trader states a number of times that he has done nothing wrong: a case of protesting too much perhaps. He goes on to say that in order to balance the books he will pay for the missing horse when he next travels to the capital: indicating to the reader of this document that there was more to this story than the failure of a Tibetan trader to pay for a horse. This leads one to suspect that the horse trader had indeed sold the horse and kept the money for himself. A document regarding another case of corruption in which a leading government figure and member of the aristocracy responsible for tax collection had embezzled taxes to pay for his father's funeral indicates that corruption may have been quite widespread. Indeed there are numerous documents in this archive written to tax collectors to collect the appropriate amount of tax, not to put strain on the ordinary people and pay the total amount of tax to the government.

The Unfortunate case of the commoners of La chen and La chung. In a series of documents regarding La chen and La chung a picture emerges of life in north Sikkim during the nineteenth century: and it is not an altogether pleasant one. Given the distance of La chen and La chung to the centre of Sikkimese political power, it appears that northern Sikkim was administered in a way resembling the American wild west, where like Sikkim the authority of the government felt very distant from everyday life and was thus either ignored or bent to suit the needs of particular individuals. The letters in the Palace Archives, written by ordinary citizens of La chen and La chung illustrate the abuse and misuse of political power and the extortion rackets run by powerful individuals. In one letter the people of La chen complain to the Chogyal about one Padma rta mgrin (a dpon po) and his son, who introduced laws forbidding the La chen pa from grazing their livestock on the pastures surrounding the region, in some cases using force to extort money and "taxes". The Sikkimese King responds to this letter in another document in which he states that the La chen pa had suffered many difficulties caused by two "bad" people, who are later mentioned by name as Padma rta mgrin and his son. The Chogyal adds that the La chen pa could now pasture their livestock in the region periodically, but not all at the same time so as to ensure the longevity of the pasture lands for the future and instead of paying their taxes directly to the King (as some had done so to bypass Padma rta mgrin) and avoid travelling to southern Sikkim to do so, they could pay their taxes via Gam pa in Tibet.²

² There seems to have been a mutual taxation obligation to Sikkim by the people of Gam pa and La chen. In another series of documents a dispute arose between Gam

Another case of the mistreatment of ordinary citizens from northern Sikkim can be found in a document from the early nineteenth century. In this document the people of La chung complain to the Chogyal about two individuals Khol nag and Tshe dbang rdo rje, who came to La chung with a group of Nepali hard men and roughed up the locals forcing them to pay “protection” money. It notes that these two people even attacked the local official Phun tshogs dngos grub, who was forced to pay 8 *srang*, 1 *zho*,³ and *kha brtags*. Others were forced to pay *chang* and 30 *rgya Tam*.⁴ Unfortunately the Chogyal’s response has been lost and so the outcome of this complaint is unavailable. What, however, can be seen with these examples from La chen and La chung, is the life and experiences of ordinary people in Sikkim.

An extradition treaty between Sikkim and Bhutan. In 1901 Sikkim and Bhutan signed an extradition treaty the details of which allow for an annual transfer of prisoners between the two countries. Prior to this treaty it appears as if torture was widespread within both governments’ prisons as within this document they agree not to torture prisoners “too much”. This document is the culmination of a series of incidents involving Sikkimese and Bhutanese prisoners. For example in a document dated 1866 from sPa gro to the Tibetan representative at Phag ri, they ask the Phag ri rdzong dpon to intervene on their behalf to secure the release of a Bhutanese prisoner held in La chen and ‘Gro mo. In this letter the Bhutanese state they are willing to travel to Sikkim with money and tea to ransom the prisoners, or failing that hold a tripartite conference on the border of Tibet, Sikkim and Bhutan, but if that request is refused they would ask the British to arbitrate the case. Another undated document details the case of a Bhutanese man named

pa and Sikkim, which culminated in a negotiated settlement involving representatives of the governments of Sikkim, Tibet and the regional leaders of La chen and Gam pa. So serious was this dispute that the Phyag mdzod (Chancellor) of Tibet wrote to the Sikkimese government on numerous occasions. In addition the Panchen Lama also got involved and there survive a number of letters from this Lama in the Palace Archive.

³ *Srang* and *zho* are units of measurement. These units are commonly found within the wider Tibetan world. Throughout Tibet a *srang* is equal to 50 grams and ten *zho* are equal to one *srang* (i.e. one *zho* is equivalent to 5 grams). In a separate document in the Palace Archive the values of these measurements are given as one *zho* is equivalent to ten *srang* (i.e. one *Zho* is equal to 500 grams). If this was indeed the case then it appears Sikkim may have used its own unique form of weights and measures.

⁴ *Rgya tam* normally refers to Indian coinage, though in the early nineteenth century British influence had yet to reach northern Sikkim, in which case the use of this term here may refer to other coins.

dPal sbyor, who stole some property from a La chung pa whilst he was in Ha valley. The La chung pa then went to 'Gro mo to make a complaint to the Sikkimese government. Eventually dPal sbyor was captured and instead of receiving a trial was handed over to the La chung pa and 12 people from 'Gro mo who then killed him. This document echoed by numerous other documents illustrate the lawlessness of the Sikkim/Bhutan border and the need to create a legal framework to deal with captured criminals from either country.

The Ri nag documents

In July of this year (2009) fifty four documents were donated to NIT by the family of Ri nag via Tenzin Chuki Tashi a Research Assistant at NIT. They are now housed within the Archive room, along with the Palace Archive, at NIT. Hissay Wongchuk has been working on these documents and has compiled a short list of the material in this collection, which will be published in due course. The documents date from 1875-1919, though the majority of the material is from the 1870s-1890s. The majority of the documents are bound in Tibetan style (i.e. bound dpe cha format) and are accounts and taxation registers for the lands under the control of the Ri nag rdzong dpon. In addition within this collection are almanacs, expenditure lists for J.C. White (the first political officer in Sikkim from 1890-1908) and details of the expenditure of structural work such as the construction of bridges, etc. Further study of this material may prove useful in determining the precise events and details of the Tibet-Bhutan-Sikkim border dispute over Ri nag in the early twentieth century.

Final remarks

The acquisition of these important documents for the study of Sikkimese social and political history, by NIT, illustrate the growing importance of this institute as a resource for scholars of Tibet, the Himalayan region and Sikkim itself. Indeed the recent focus of the institute towards the study of Sikkim has brought increased academic interest in this region. Together with this growing international interest in Sikkim and the infrastructural and technological developments of NIT, there is now a recognised institution capable of housing rare and fragile manuscripts and providing a base for international and local scholars alike. Indeed the recent successes in the acquisition of the Palace Archives and a selection of documents from Ri nag shows that NIT can now be considered a safe repository for rare manuscripts and archival collections.

Forthcoming publications

Saul Mullard and Hissey Wongchuck

Royal Records: The Sikkimese Palace Archives

This book includes a detailed catalogue of documents found in the Palace collection. It also included chronological tables for the Sikkimese Royal family, royal palaces and residencies used throughout Sikkimese history as well as a note on official seals of Sikkim, Bhutan and Tibet. The Namgyal Institute of Tibetology will be accepting orders for this book from December 2009.

THE BRITISH RESIDENCY
IN THE HIMALAYAN STATE OF SIKKIM:
A HERITAGE BUILDING RESTORED TO ITS FORMER GLORY

ANNA BALIKCI-DENJONGPA
Namgyal Institute of Tibetology

On a hill top above the Himalayan town of Gangtok stands a splendid two-storey Victorian mansion built in the style of a typical British country house. Somewhat out of place, it stands as a reminder of the British Raj and its eventful role on the Tibetan Frontier. The Residency, as it used to be known, was the official residence of the political officers in charge of overseeing the British Empire's interests in the region and its relations with Tibet and the Himalayan kingdoms of Sikkim and Bhutan. In British India, political officers were advisors to the rulers of the princely states though they also served as special envoys or ambassadors in areas beyond the frontier.

Between the year of its construction in 1890 and the departure of its last British incumbent in 1948, the Residency was the home of extraordinary men who all shared a fascination with Tibet or Central Asia. Some of these political officers along with their guests, such as Sir Charles Bell and Sir Francis Younghusband became famous for their diplomatic and military exploits or their writings about Tibet and the Dalai Lama. Over the years, the Residency Gangtok received a large number of visitors as it was the last post on the way to Tibet before officers, scientists, and Everest mountaineers started their arduous journey across the Nathula pass and into the Chumbi Valley of Tibet. It was described by Sir Basil Gould in his memoirs *The Jewel in the Lotus* as "perhaps the most attractive medium-sized home in the whole of India" (1957: 168).

Today, the Residency, now known as Raj Bhavan, is the official residence of the governors of the Indian state of Sikkim. Damaged and rendered too unstable for habitation by an earthquake in 2006, this silent witness of history has recently been restored to its former glory by the present Governor of Sikkim, Shri Balmiki Prasad Singh.

Jean Claude White

The Residency came into existence as a result of a conflict which arose in 1886 between British India and Tibet over the latter's occupation of

a fort located well within Sikkim territory. Following the evacuation of the Tibetan force in 1888 and the restoration of peace on the frontier, it was thought necessary to appoint a resident political officer to overlook the administration of Sikkim and keep Tibetan influence at bay. The responsibility fell upon Jean Claude White (1853-1918), an engineer from the Public Works Department with no political training or diplomatic experience who remained in Sikkim for nearly twenty years. White is well remembered in Sikkim for having established an administration along with a simple form of law and justice. He built roads, bridges and bungalows, as well as the first schools and hospital. He “encouraged industrious immigrants from Nepal to settle in the almost unpopulated southern areas of the State” (Gould 1957: 169), a migration that greatly contributed to the agricultural development of the region.

Shortly after his appointment, White set out to establish an official British residence in Gangtok. After selecting a charming site in the midst of primeval forest with magnificent views on the snow peaks of Mount Kangchenjunga, he went about the construction of his house with great difficulties. As described in his memoirs *Sikkim and Bhutan: Twenty-One Years on the North-East Frontier* (1909), the ground first had to be levelled, trees had to be felled, stones quarried, and masons and Punjabi carpenters imported. Eventually, after eighteen months of labour, White moved into his British country home in the midst of the Himalayas, complete with veranda and furniture from Oxford Street, before Christmas of 1890. For over a century, visitors have not ceased to admire White’s architectural marvel along with its collection of Himalayan artefacts and luxuriant gardens.

Sikkim was then ruled by a Maharaja who was under British control and as Alex McKay points out in *Tibet and the British Raj: The Frontier Cadre, 1904-1947* (1997) “British influence was symbolised by the concrete road which ran from the Maharaja’s palace to the British Residency.” The latter was located on a higher ridge overlooking the Palace, a clear statement of White’s views of the dynasty of Tibetan origin that had established and ruled Sikkim since the 1640s.

The Residency first came to the attention of the world following the 1903-4 British expedition to Lhasa which sought to establish diplomatic and trade relations with Tibet. Perceval Landan, The Times correspondent on the Younghusband Expedition describes his arrival at the Residency in his book *Lhasa* (1905), “The double Residency gates open and shut behind one, and through the tree ferns and dying

bamboos of the drive one emerges into the English roses and clean, short turf of Mrs Claude White's home-made Paradise." On the eve of the British troops advance to Gyantse, the Residency was the scene of the equally publicised wedding of J.C. White's daughter Beryl to Captain HG Hyslop of the 93rd Highlanders on April 19, 1904.

For the Sikkimese however, the Residency had already become a fascination even before its completion, the Maharani herself struggling to comprehend how a building with such thin walls could ever stand up. She was soon proven wrong when the earthquake of 1897 destroyed her palace, built in Tibetan style with walls as thick as 4 feet 6 inches, while the Residency, though badly cracked, remained standing. White adds that "Almost every market day little bands of women dressed in their best clothes would arrive with a few eggs or a pat of butter to make their salaams to my wife and a request that they might be allowed to go over the house, and their progress was marked with exclamations and gurgles of laughter at the strange ways of the Sahib-log" (1909). The semi-circular design of the Residency's bay window was subsequently copied by both the Palace and the local aristocracy's Gangtok residences.

J.C. White recounts that the Residency garden was "a great joy and an everlasting source of amusement and employment" to himself and his wife. He comments on the beautiful green lawns they enjoyed even in winter, the profusion of early spring bloom "seldom seen in England," the delicate mauve of the abundant wisteria on the house and the wealth of roses that "flowered in such profusion, thousands of blooms could be gathered without making the smallest impression." He reports how his office was covered in roses and was an outstanding sight: "Perhaps the most beautiful sight was my office, a building a few hundred yards from the house, which was completely covered, roof and chimney included, with roses, and was a sight worth coming miles to see."¹

Sir Charles Bell

Following J.C. White's retirement in 1908, Sir Charles Bell (1870-1945) was appointed Political Officer Sikkim, Bhutan and Tibet. With the success of the Younghusband expedition, followed by the establishment of diplomatic relations with Tibet and the establishment of British trade agencies in Yatung and Gyantse, the attention of subsequent political officers naturally turned to Lhasa. Bell moved into

¹ kcl.ac.uk/about/history/archives/india/domestic/garden.html

the Residency in October 1908 which he occupied for the better part of a decade. He taught himself Tibetan and as McKay points out “Bell was very much the scholar-administrator of ICS tradition” and eventually came to be regarded as “the architect of Anglo-Tibetan policy and friendship.”

However, Bell’s contributions to Sikkim’s indigenous population were no less significant and farsighted. He protected villagers from the exploitation of merchants and money lenders by limiting their settlement in the interiors of the country. He prevented the settlement of outsiders in the Bhutia and Lepcha regions of North Sikkim, and introduced Revenue Order 1 of 1917, which is still in force today and precludes the sale of Sikkimese Bhutia and Lepcha land to any other ethnic community.

Bell was also a collector of Tibetan and Himalayan art and the Residency was soon overflowing with artefacts including thangkas, bronzes and curios of all kinds complete with two life size effigies of Bhutanese bodyguards in full armour standing on either side of the Residency’s stair case. His contributions to the Residency were a tennis court built in May 1909 by a Darjeeling contractor and the plantation in 1915 of over 1000 oak, magnolia and walnut trees in the residency compound with the view of providing fire wood and timber to his successors.²

As political officer for the region he was responsible for the Dalai Lama during his 1910-12 exile in British India. The two formed a lasting friendship and at the invitation of the Dalai Lama, Bell spend nearly one year in Lhasa on a diplomatic mission in 1920-21. After his retirement, Bell wrote a number of books on Tibetan history, culture and religion, as well as a last volume on his friend the 13th Dalai Lama which, already in the 1920s, revealed much of this obscure yet fascinating culture to the outside world by someone who had not only become intimate with its people but had himself become largely ‘tibetanised.’

Campbell, O’Connor, Macdonald, Bailey and Weir

In 1918, Bell relocated to Darjeeling where he devoted two years to the study of Tibet. Major W.L. Campbell took over as Political Officer Sikkim, Bhutan and Tibet in 1918 but unexpectedly resigned in 1920, allowing Bell to resume for a year on the understanding that he would return to Tibet. After a short stint by Lt-Colonel W.F. O’Connor, the

² Sir Charles Bell diaries (Jonathan Bracken personal collection).

next political officer to occupy the Residency for a number of years was the famous frontiersman Lt-Colonel F.M. Bailey (1882-1967). He relieved David Macdonald in 1921 who, for a few months, had himself relieved Bell while he was in Lhasa. Bailey time's as Political Officer Sikkim, Bhutan and Tibet was not the highlight of his career and coincided with a down-turn in Anglo-Tibetan relations (McKay 1997: 102). Bailey remains better known for his spying exploits in Central Asia at the time of the Great Game. However, with an interest in butterflies and botany, Bailey is remembered for having introduced a large number of interesting plants in the Residency garden. He shared this interest with the famous British botanist Frank Kingdon-Ward for whom he arranged passports to Tibet to search the fifty-mile unexplored gap of the Tsangpo river. In 1928, Bailey was succeeded by Major J.L.R. Weir who, according to McKay (*ibid.*: 121), followed the example of Bell and succeeded in improving Anglo-Tibetan relations through skilful diplomacy.

Frederick Williamson

Frederick Williamson (1891-1935) took over as Political Officer Sikkim, Bhutan and Tibet in 1933. He was accompanied by his wife Margaret who later wrote *Memoirs of Political Officer's Wife in Tibet, Sikkim and Bhutan* (1987). The Williamsons were married at Gangtok, the ceremony conducted at the White Memorial Hall by Dr Graham followed by a garden party for 300 guests at the Residency. From her book it is clear that the Williamsons did a great deal of entertaining since the Residency, along with the dak bungalow, were the only two places where Europeans could stay. Their long list of guests included government officials, army people, foreign ambassadors, botanists, friends from Lhasa, like the Tarings and the Tsarongs, Rani and Raja Dorji of Kalimpong, and even Sir Charles Bell *en-route* for his last visit to Tibet in 1934. She vividly remembers the members of the 1935 Everest Reconnaissance Expedition "all setting off down the garden with ice-axes and umbrellas, with those two great mountaineers, Eric Shipton and H.W. Tilman, carrying between them a wooden strong box full of cash to cover all the expedition's expenses." Margaret complained that there were in fact so many visitors "that sometimes there barely seemed enough time to change the sheets between one set of visitors and the next." She took a special interest in the garden and accompanied her husband on all his tours of Sikkim, Tibet and Bhutan.

Williamson's tenure as political officer remained short as he tragically died of kidney disease while on duty in Lhasa in November

1935. The years the Williamsons spent at the Residency were certainly the happiest of their lives.

Sir Basil Gould

Sir Basil Gould (1883-1956) took over as Political Officer Sikkim, Bhutan and Tibet in 1935 and remained in Gangtok for a decade until the end of the war. Gould is remembered for having established a permanent British Mission in the Tibetan capital and having attended the enthronement of the 14th Dalai Lama in Lhasa in 1940. In Gangtok, Gould was very popular and is still fondly remembered. One of his lasting contributions to the town is a football field which he built in memory of his wife Lorraine and which had to be literally carved out of a mountain side.

As recounted to me by his son Dick who spent his summer holidays of 1939 at the Residency, there was always a constant stream of visitors and a succession of parties, from informal to large garden parties with band, dancers and plentiful food. Gould had a lot of guests who were official or semi-official: the Governor of Bengal and family, visitors from the British communities in Darjeeling and Kalimpong, travellers who passed through Sikkim, and notably the Everest parties of his era. The Maharaja of Sikkim and his family were regular guests at the Residency where Gould tried to gradually widen their horizon and to lessen their shyness of the outside world. The garden was a great delight of his. He was once complimented on being a great gardener and replied that he was not much good at gardening, but he was quite good at employing 40 gardeners!

Arthur Hopkinson

A.J. Hopkinson (1894-1953) succeeded Sir Basil Gould in 1945 as the last British Political Officer Sikkim, Bhutan and Tibet. He remained in Gangtok until after Indian Independence as Indian political officer, handing over to Harishwar Dayal ICS in 1948.

As recounted by Roger Croston in her obituary (2006: 156), when Mrs Hopkinson joined her husband at the Residency, she had to put her foot down to bring the household in order again. Following Gould, the Residency was always full of visitors: "They poured through – things had got out of hand. Even the guidebooks stated that Europeans should travel with dinner jackets, as they would probably dine there. It had

become a habit of people from Calcutta who had few wartime places to visit on leave. They wanted permits for Tibet – as far as Phari – so they could claim to have been there, yet the Tibetans didn't want them all, the country simply could not feed them." She found the Residency servants marvellous, Sikkimese who had been in the service of the political officers for 20-30 years.

On the 1st of September 1948, Arthur Hopkinson handed over his post to his Indian successor. Mrs Hopkinson's entry in her diary for that day reads as an epitaph for the British Raj, "Today we are no longer masters of The Residency." The entry for September 3rd reads: "a difficult departure. It was very hard to say good-bye to all our good, old servants, so kind and willing, and friends like Sonam and Lobzang. We were loaded with garlands. The school children all turned out and nearly the whole bazaar and the Christian community. It was all rather harrowing especially for Arthur. Later we threw our enormous wads of garlands into the Tista" (*ibid.*: 158).

As McKay has pointed out, "With British power in the East rapidly declining, Hopkinson was an appropriately thoughtful, even philosophical figure (1997: 166). He observed a decline in the moral climate of Tibet and a certain aristocratic decadence in the years 1933-1947 following the death of the 13th Dalai Lama, both Chinese and British policies having contributed to the situation (*ibid.*: 176). "Hopkinson was particularly concerned that the encounter with modern culture had brought 'the worst aspects of capitalism' to Tibet" (*ibid.*: 177). Interestingly, "Hopkinson also began to question the accepted ethical values underlying the imperial process. Noting 'the happiness, contentment, self-sufficiency, and liberty' of its people, he concluded that 'the modern world has more to learn from Tibet than to teach [it]'" (*ibid.*: 177).

India House and the Indian Political Officers

Following Indian independence in 1947, a series of Indian political officers were assigned to Gangtok between 1948 and 1975, the year the Kingdom of Sikkim ceased to be a protectorate and joined the Indian Union as its 22nd State. India's responsibilities in Tibet came to an end in 1950 and Bhutan was eventually separated from the political officer's jurisdiction in 1971 (Datta-Ray 1984: 65-66). The Indian political officers were: Harishwar Dayal, Apa B. Pant, Inderjit Bahadur Singh, Avatar Singh, V.H. Coelho, N.B. Menon, Kayatyani Shankar Bajpai and Gurbachan Singh.

The official residence of the Indian political officers continued to be known as the Residency although it was locally referred to as *burra kothi*, the big house. With the view of severing with imperial traditions, Mrs Gandhi agreed to rename the Residency India House in 1968 (Datta-Ray 1984: 64-65).

Sir Basil Gould's son who had spent his summer holidays at the Residency in 1939 visited once again in 1970 and was very cordially greeted by Mrs Bajpai. He observed that the interior atmosphere had radically changed from English country house comfort to something much more austere. Mrs Bajpai herself commented on this with deep regret as she would have loved to have preserved the old atmosphere, but when India inherited the administration of Sikkim the decision was taken deliberately to alter the style. Already by then, Dick Gould noticed that the Tibetan art collections were no longer on display.³ To this, Datta-Ray adds that it was a sadly denuded mansion, stripped of its deep carpets, fine china and gleaming silver that the last Indian political officer left (1984: 321).

Raj Bhavan and the Governors of Sikkim

When Sikkim formally joined the Indian Union, Shri B.B. Lal was made Governor of Sikkim in May 1975. This marked the conversion of India House to Raj Bhavan. Shri B.B. Lal was succeeded as Governor of Sikkim by the following governors: Sarva Shri H.J.H. Taleyar Khan, K. Prabhakar Rao, B.N. Singh, T.V. Rajeshwar, S.K. Bhatnagar, R.H. Thailiani, P. Shiv Shankar, K.V. Ragunath Reddy, Chaudhary Randhir Singh, Kidar Nath Sahani, R.S. Gavai, V. Rama Rao, and Sudarshan Agarwal.

Restoring Raj Bhavan to its Former Glory

Under the guidance of the present Governor of Sikkim, Shri Balmiki Prasad Singh, the heritage building recently underwent a thorough renovation which should fortify it and ensure its stability for another hundred years. Although the erstwhile Residency retained its original appearance, its structure was completely renovated through 'retrofitting,' a technology used to restore a centenary old building's youth and strength. Retrofitting has so far only been used on two other

³ Personal communication Dick Gould.

heritage buildings in the country: the Rashtrpati Bhawan in Delhi and the Taj Hotel in Mumbai.⁴

Over the many decades, the British country house build by J.C. White in 1890 witnessed a great deal of Himalayan and Central Asian history. From the demise of Tibet in 1959 to the establishment of the Kingdom of Bhutan in 1907 and eventually the ascension of the Kingdom of Sikkim to India in 1975, the building was not only the theater of unfolding history but also the home of extraordinary men who helped shape the future and development of the region.



Indian Prime Minister Pandit Jawaharlal Nehru arrives at the Residency in 1958 where Apa Pant, the Indian Political Officer waits to receive him (IPR Collection, Govt of Sikkim).

⁴ *Now!* 19 April 2009, Gangtok, Sikkim.

BIBLIOGRAPHY

- Croston, R. 2006. Eleanor Hopkinson (1905-2007). *Bulletin of Tibetology*, Vol. 42, no. 1&2. Gangtok: Namgyal Institute of Tibetology.
- Gould, B.J. 1957. *The Jewel in the Lotus: Recollection of an Indian Political*. Chatto and Windus: London
- Landan, P. 1905. *Lhasa: An Account of the Country and People of Central Tibet and of the Progress of the Mission sent there by the English Government in the Year 1903-4*. London: Hurst and Blackett.
- McKay, A. 1997. *Tibet and the British Raj: The Frontier Cadre 1904-1947*. London Studies on South Asia 14 (SOAS). London: Curzon.
- Datta-Ray, S.K. 1984. *Smash and Grab: Annexation of Sikkim*. New Delhi: Vikas.
- White, J.C. 1909. *Sikkim and Bhutan: Twenty-One Years on the North-East Frontier 1897-1908*. New York: Longmans.
- Williamson, M.D. 1987. *Memoirs of Political Officer's Wife in Tibet, Sikkim and Bhutan*. London: Wisdom.

BOOK REVIEW

ALEX MCKAY

International Institute for Asian Studies, Leiden

Bahudhā and the Post 9/11 World. Balmiki Prasad Singh.
Delhi: Oxford University Press, 2008.

As Mahatma Gandhi reminded us, in darkness there is always light, and in the most troubled times there are always voices seeking solutions rather than emphasising the problems. This timely work is, as its author states, “an individual’s effort to seek a way of reconciling the disturbing disorder of our times” (p.xvii). Appropriately enough it has a foreword by that apostle of peace and reason, His Holiness the 14th Dalai Lama of Tibet. Its author, Balmiki Prasad Singh, now the Governor of Sikkim and formerly Culture Secretary (1995-97) and Home Secretary (1997-99) in the Government of India, was serving as one of the Executive Directors of the World Bank representing India, Bhutan, Bangladesh and Sri Lanka in Washington on 9/11, when the attacks on the Twin Towers and the Pentagon took place. Clearly there were many—indeed an overwhelming majority of America’s leaders—whose first thoughts were of war. But as history already tells us, a more thoughtful and considered response was actually needed.

John Lennon, quoted here in the opening lines, *imagined*, we might say dared to imagine, a different world, one in which mankind could live as one. Like Gandhi he paid the ultimate price despite his hopes of peace, and how that world might be created was left to others to dream of, and to plan. Already we live in an interdependent world, as the earlier and subsequent attacks on Mombassa, Mumbai, Bali and a host of other places has demonstrated. But the question remains; how might this world be one of peace and harmony?

The concept of *Bahudhā* (from the Sanskrit *bahu*, meaning many forms, ways, or paths; adverbialised by *dhā*), which might be best rendered in English as ‘pluralism’, is the model advanced here as a solution to the problems of humanities’ multiple conflicting aims. The term is used here, “to suggest an eternal reality or continuum, a dialogue of harmony, and peaceful living in society” (p.xiii). It is a multi-layered concept, allowing the centrality of diverse religions in the modern world yet reflecting also an essential humanism, involving a

deep respect for others which facilitates dialogue between individuals and states.

Bahudhā and the Post 9/11 World begins by situating the modern world in a historical context which emphasises the eternal centrality of government to society. At its most basic, a compact exists between ruler and ruled, ideally the former expressing the will of the latter. In the context of Indian society, the second chapter considers the Vedic worldview, born in the conflicts of migration into the Punjab under Indra's banner, but through the philosophical and spiritual speculation and revelations of the Vedic poets, the *rsis*, emerging with an understanding of the necessity of respect for the points of view of others. In the more morally complex, even ambiguous message of the Epics, conflict resolution emerged in a Dharma-based moral order, with Dharma the central foundation of social harmony. Here perhaps, the author might have gone further, for, as I understand that concept, the ultimate authority in deciding what the Buddhists call 'right action' in the context of an individual's *varnashramadharma* is the individual themselves, which implies our own individual responsibility to community and as global citizens.

The Indian heritage absorbs, generally peacefully, many cultures within its own, thus allowing multiculturalism. But the Vedic world and its inheritors were not without fault, for as the author stresses, the failure to allow the education of women and the creation of untouchability (scheduled castes) outside of *varna* were both detrimental to progress, and in the modern world, anachronistic and anti-national. Yet from that Vedic heritage, the experience of conflict resolution produced individuals and an over-arching ideology that is relevant to much of the problems of today's world and the question of solutions to those problems. As we read in chapters Four and Five, that heritage has produced 'pathfinders'—Mahavira, the Buddha, Guru Nanak, and others who showed how we might live peacefully, and 'builders' such as Vivekananda, Gandhi, and Tagore who further added to that development of righteous living with their addition of such crucial concepts as non violence to the earlier lessons. India also produced rulers such as Ashoka, (for whom Dharma became a state policy), Akbar, and Nehru, who at least reflected those ideals, recognised their validity, and generally tried to implement them in society.

Seeking to explore these ideals further the author visited places in Kerala, West Bengal, Jharkhand, Bihar, and Assam, "to bring out how the common people in India retain the essence of harmonious living

and manage crises and conflicts...in their everyday life....” (p.195). He found that amidst great cultural change religious culture survives, and that where—as in Naxalite Jharkhand—communication and dialogue has broken down, conflict follows. At the other end of the spectrum in places such as Hajo—and one thinks also of Rewalsar in Himachal—religious distinctions break down, and social harmony is enhanced. Thus might *Bahudhā* be seen, as Part Three is entitled, as “an Instrument of Public Policy for Harmony.” One thinks of this pluralist ethos in the closely related context of Bhutan’s concern with Gross National Happiness. In a land neighbouring India this is a genuine enquiry into alternatives to what often seems the world’s primary concern with violent enforcement of ideological goals.

After considering the rise of the secular West, shaped by the philosophies of Marx, Darwin, Nietzsche, and so on, the author advances the concept of *Bahudhā* as a means of conflict resolution through which there can be “persevering and attempting to solve problems according to the principles of peace,” (p.240), and then discusses what needs to be done to achieve this. The dangers of fundamentalism are ever present. In India, for example, there has been the recent stain of events in Gujarat, but as stated here, much of this tendency can be eliminated through education for all. It is through knowing other paths that they can be respected, and the wider idea of one truth and many paths be understood. Prejudice flourishes best among the uneducated.

In discussing the “International Political Architecture” (Chapter 11), the author points out the agreement between *Bahudhā* and the core philosophy of the United Nations as well as the fundamental principles of democracy. Can, he asks, we turn these ideals into reality and make *Bahudhā* a global creative venture—a cornerstone of the plural society and liberal democracy? Such questions need to be constantly asked, and it should be no surprise if the best solutions tend to be age-old, because people of goodwill have asked them throughout history.

If the solutions are to be applied, education is indeed a key, and this work would make an excellent textbook for schools. It is a scholarly and humane work, eminently readable and drawing on a wide range of sources and experiences. It represents the voice of reason that must be heard if our species and its world are to long survive.

BOOK REVIEW

SAUL MULLARD

Namgyal Institute of Tibetology

A Rosary of Rubies: The chronicle of the Gur-rigs mDo-chen Tradition from South-Western Tibet, Ehrhard, Franz-Karl, Munich: Indus Verlag, 2008, 267pp. Language: English and Tibetan

This book is a critical edition of a Tibetan text entitled *Dpal ldan gur rigs mdo chen brgyud pa'i lo rgyus nyung ngu'i ngag gi brjod pa padma rā ga'i phreng ba zhes bya ba bzhuḡs so* or in English: [A] *History of the Glorious Gur rigs mDo chen [Tradition], a speech of a few words [entitled] "A Rosary of Rubies"*. The book begins with a detailed and informative history of this tradition, placing it within the 'Brug pa sub-school of the bKa' brgyud pa school of Tibetan Buddhism. In this introduction Ehrhard details the origination of this sub-lineage of the 'Brug pa school by tracing the origins of one Ma bdun pa mDo bo che ba (12th/13th centuries) as a disciple of rGod tshang pa mGon po rdo rje (1189-1258) who established the *stod 'brug* (Upper 'Brug) branch of the 'Brug pa.

Ehrhard states that Ma bdun pa mDo bo che ba was associated with the region of sKyid grong in South Western Tibet, where the cult of the 'Seven Ma mo sisters' was prevalent and makes the connection between the name of the founder of the Gur rigs mDo chen tradition and this cult of female religious protectors found in the region. Ehrhard then contextualises the development of the Seven Ma mo sisters as territorial goddesses of malignant nature until their conversion to protectors (according to local tradition) by Padmasambhava and their role in the different religious traditions and schools of Tibet. His treatment of the development of this cult throughout the history of this region provides the reader with, not only, an interesting historical account but also of the linkages between this cult, the rNying ma school/*gter ma* (in the person of dMar zhabs ras pa who discovered three paper scrolls relating to this and who also disseminated a similar cult of female territorial protectors), the region and other similar cults.

Following this section Ehrhard begins to contextualise the mDo chen bKa' brgyud pa, beginning with some background information to the text that appears later in this book. He notes that this text appears as

a supplementary text to another work called *mDo chen bKa' brgyud gser 'phreng*. This introduction to the edited text helps to provide detailed information for the reader on the content and history behind the text. He then provides a historical introduction to the Gur family including a useful genealogical table for the reader to refer to, when reading either the Tibetan text or English translation.

Part two of this book includes the edited Tibetan text and English translation. Ehrhard's treatment of the Tibetan text, in particular the editing method, makes the Tibetan text easier to read. Whereas most scholars choose to transliterate the Tibetan text exactly as it appears in the original, Ehrhard has chosen to edit the transliteration and provide rejected spellings in footnotes; this allows the reader to read the Tibetan text clearly without constant reference to footnotes. In addition for those readers wishing to look more critically at the text he provides a facsimile of the original document (as plates) at the end of the book.

The translation of the Tibetan text, which follows the edited Tibetan, is precise and detailed. It offers the reader contextual information in footnotes as well as dating references in the main text, allowing the reader to follow the chronology of the text as well as clarifying certain points in the main translation. The text could have benefited from a presentation of the Tibetan text alongside the translation, perhaps on a folio by folio basis to allow the reader to follow both the Tibetan text and the translation sequentially. However, given that this is such a minor issue it does not detract from the importance of this work towards our knowledge of the little-known and even less studied Gur rigs mDo chen tradition of the upper 'Brug school. I would recommend this book to anyone interested in this tradition and the religious traditions of South-Western Tibet.

BOOK REVIEW

MARK TURIN

University of Cambridge

Tibetan Modernities: Notes from the Field on Cultural and Social Change. Edited by Robert Barnett and Ronald Schwartz. Proceedings of the Tenth Seminar of the International Association for Tibetan Studies, Oxford, 2003. Brill, Leiden and Boston, 2008, 456 pp., Hardcover, ISBN 9789004155220.

Described on its back cover as “the first major publication in the west to study...modernity and its impact on contemporary Tibet,” the present volume certainly lives up to its claim. Edited by two of this emerging field’s most productive scholars, Robert Barnett and Ronald Schwartz, *Tibetan Modernities* is a timely collection of writings on many aspects of socio-cultural life among contemporary Tibetan communities.

Barnett’s deftly written Preface charts the emergence in little more than a decade of what may be termed ‘modern Tibetan studies,’ despite the ideological, political and practical obstacles that have at times impeded the development of this fledgling discipline. When Barnett takes stock of the volume of research projects and their ensuing publications, one is struck by the realignment of Tibetan studies from a loose confederation of Buddhologists, historians and other textual scholars whose primary focus was on Tibet’s religious past, to a dynamic field represented by researchers from the region as well as those based in foreign universities, engaged with transformation, change and the challenges of modernity. While Tibetologists may still read Sanskrit and classical Tibetan, many now also speak and read Chinese, and can converse in a range of different Tibetan dialects. Contemporary music, art, education, development and the environment have all become objects of critical analysis and study. This historical shift in interest has been accompanied by increasingly nuanced positions on the political aspects of modern Tibet, informed by long-term fieldwork, and greater fluency in the linguistic and social forms that constitute present-day Tibetan communities. Rather than paraphrasing Barnett poorly, allow me to present his statement in full:

The discussion of Tibet in the international academy has therefore not been merely a shift from the southern to the northern slopes of Tibet, from exile to the inside, from reconstructional cultural anthropology to the politics of contemporary colonial-type tensions, or from a victimisation view to a recognition of agency. It has increasingly acquired the hue of a much more challenging inquiry into the nature of modernity within the context of late-socialism in Asia, and into its particular features in the Tibetan encounter. Such a project has required not just the study of Tibet or Tibetan culture but a self-reflexive assessment of the outsiders too, and of the contours of the fields within which they work. (xvii)

The present volume is both a tribute to and manifestation of the emergence of Tibetan studies as an areal speciality, with established international research centres and institutes dedicated to its progress.

The *Tibetan Modernities* volume is divided into four sections. After an introduction by Ronald Schwartz, to which I return below, there are four contributions on modernisation and social change, three articles on the pedagogy of modernity, two contributions on contemporary Tibetan art and cinema, and four articles on issues relating to new media and public space.

Schwartz's introduction is necessarily carefully worded. He takes care to unpack the historically inaccurate construction "of a binary opposition of tradition and modernity" which has become so emblematic in characterisations of Tibet (p. 3). Developing a discriminating understanding of modernity is particularly important given that for much of the 20th century, Chinese government philosophy displayed a 'virtual obsession' with the concept of modernity as a driving ideological force for change and progress. Schwartz marches the reader swiftly through theories and critiques of modernity, while at once keeping the discussion firmly grounded in the social realities of Tibet, before moving on to discuss the papers in the present volume. He concludes his introduction with an important disclaimer on the nature of the contributions—because modernity itself is by nature a decentred, mobile and chameleon-like force, the articles in the volume do not reflect a normative or systematic account of contemporary social life in Tibet. Modernity is in many ways also post-modern, and the volume's contributions are also by definition "local and site-specific enactments" (p. 31).

Emily Yeh's paper, the first in the collection, deals with the establishment of state farms in Tibet—'modern' agricultural institutions—after the arrival of the Chinese in Lhasa in 1951 through to 1980, and discusses how Tibetans experienced these institutions on a

day-to-day basis. Yeh argues that agriculture is a useful lens through which to view larger socio-economic questions on account of its central place in Chinese discourses of modernity and development, and that agricultural modernisation was a “key state project with its own regime of truth” (p. 38). The author charts the founding and the fortunes of two state farms, named 7-1 and 8-1, forerunners whose trajectories prepared the groundwork for a whole system of state farms across the Tibetan Autonomous Region. Yeh’s contribution is a model of the successful interweaving of ethnographic detail with remembered and recorded history. Her article also serves as a prudent reminder of the paradoxical nature of the modernist experiment which transformed the lives and livelihoods of Tibetans in the name of an idea, only to reconfigure and redefine that idea some years later in line with the principles of a market economy.

In her contribution on the flow of wealth among Golok nomads in present-day Qinghai province, Susan Costello shows how Tibetan pastoralists “are taking up the challenges and opportunities modernity brings without abandoning their traditional values” (p. 110). The details which she furnishes on per capita income and household financial strategies demonstrate that economic reform has significantly altered neither the traditional mode of production, nor the customary patterns of resource sharing that have long been predicated on hospitality and generosity. It may be, as Costello argues, that these enduring social welfare practices in fact make up for the “retreat of the state from [the] provision of these services” (p. 110), a fortuitous example of culture and tradition withstanding the winds of change.

Heidi Fjeld looks at changing perceptions of unclean, impure or polluting activities after the reforms of the early 1980s when land redistribution aimed to put farmers on an equal footing with one another. While the land reforms of this era did lead to an improvement in the socio-economic position of workers engaged in traditional and low prestige skills, the author concludes that these have not resulted in “any change in their positions in terms of ritual hierarchies” (p. 135). Fjeld’s paper is somewhat erratic, plucking from Louis Dumont on caste to Marcel Mauss on the social features of gift giving, and would have benefited from more careful editing.

The contribution by Jennifer Marie Chertow on childbirth in contemporary Tibet is a sobering reminder that changing approaches to health, and in particular to women’s health, are key components in the modernist agenda of the Chinese state. The author deploys a narrative device which alternates between case histories and analysis, and in so

doing effectively illustrates how gender is “at the forefront of questions regarding these variable modernities” (p. 145). Chertow’s contribution documents the ways in which the state exercises control over Tibetan women’s bodies and their reproductive health as part of a larger project to overcome the perceived backwardness of the community.

Martijn van Beek’s article on Ladakhi modernity is particularly instructive for a Sikkimese audience on account of the geo-historical similarities between Ladakh and Sikkim. The author points out the overlapping and interlinked waves of modernising projects that have impacted Ladakh, from British colonial agendas, Christian and Buddhist missionary activities, to schemes for social development introduced by the Indian government. Van Beek offers detailed historical examples to support his conclusion that despite drawing on regional, national and international influences, “Ladakhi modernity is very much a local project and product” (p. 185).

Ellen Bangsbo focuses her chapter on the different roles that education can play in larger social and political projects of modernisation, both within the PRC and among Tibetans in exile in neighbouring South Asian countries. Examining the “varying interpretations of cultural preservation and child-centred schooling” (p. 190) for Tibetans, she offers the reader a helpful history of different educational institutions from traditional Buddhist monasteries to the present. The author concludes by outlining the forces which determine parental choice in the education of their children in the Tibetan Diaspora: the desire for the preservation of the Tibetan language and cultural identity, on the one hand, while also ensuring that their children have access to the best possible education, often in elite English-medium boarding schools.

Through a careful analysis of twelve naturally occurring conversations, Kalsang Yeshe offer a preliminary assessment of Chinese codeswitching in modern Lhasa Tibetan by analysing the frequency, domains of use and typology of these linguistic forms. He makes a necessary distinction between ‘loanwords’ and ‘codeswitching,’ and concludes that the proportion of codeswitching varies greatly in the sample conversations depending on the location and topic of the verbal exchange. In certain cases, such as when telephone numbers are given, codeswitching “results from habitual usage of these Chinese codes in contemporary society” (p. 241), a clear indication of the impact of media and language on modern socio-economic life. As noted by Ronald Schwarz in his introduction, there is a belief that “Chinese codeswitching conveys a sense of being modern

and cosmopolitan” (p. 22), while speaking Tibetan does not. Kalsang Yeshe asserts that the increasing use of Chinese will continue to bring “new terms and concepts to the Tibetan language, as it already has done during the last five decades” (p. 244).

The two short contributions by artists Tsewang Tashi and Chenaktshang Dorje Tsering (Jangbu) focus on 20th century Tibetan painting and modern Tibetan film respectively. Identifying specific features of a distinctive Tibetan style, Tsewang Tashi nevertheless shows how “cultural hybridity and diversity have become important aspects of contemporary Tibetan art as Tibetan artists have come to face a greater number of challenges and influences from the outside world than ever before” (p. 266). Jangbu’s conclusion is more hard-hitting: for a variety of reasons, “up to now, not a single film representing what the Tibetans themselves wish to show and say has been seen or heard” (p. 279).

Yangdon Dhondup’s paper on the rise and development of Tibetan pop music is the first in the strongest section of the volume on new technologies of communication and media in contemporary Tibet. “Cultural production,” Yangdon Dhondup argues, “can inform us about new social transformations and identities emerging as a result of modernisation,” since for many Tibetans and scholars, modernity itself is “perceived as a threat to their history and tradition” (p. 285). Using the example of the Tibetan singer Tseten Drolma, the author convincingly shows how “what may seem paradoxical, incongruent or confused to a casual observer of the current Tibetan music scene is more precisely a process of cultural borrowing as many artists engage in what is in effect an effort to create a distinctive identity and an attempt to find a place within modernity” (p. 302).

Anna Stirr focuses her contribution on *Blue Lake*, a popular song which has come to be seen by some as the ‘unofficial anthem’ of Tibet. Many listeners hear a strong Tibetan nationalist message in the song’s lyrics, resulting in it being banned from 1989 to 1992. Through a discussion of the creation and nationalist history of *Blue Lake*, and drawing on the work of Slavoj Žižek, Stirr shows how this song has in many respects “come to embody a ‘fantasy’ of Tibetan unity” (p. 306). Stirr’s thesis is nuanced and elegant, underscoring the ambiguity and multivalence of modern messaging: *Blue Lake* remains both a “point of articulation for different, locally-influenced expressions of Tibetan national identity, and a sign that points in multiple directions” (p. 329).

Tashi Rabgey examines the social use of *newtibet.com* in the first few months of its existence, an “audacious website” which “provided a

provocative new forum for the public discussion of Tibet's contemporary predicament" (p. 333). Steering away from more traditional models of a Habermasian 'public sphere,' Rabgey instead turns to the idea of 'civil society' to help make sense of the new "virtual Tibet arena in Chinese-language cyberspace" (p. 334). In so doing, she addresses the "reproduction of power along networks of relationships throughout the social order" (p. 349). The reader is left pondering a question which she raises at the outset of her paper: has digital technology indeed "cleared a new discursive terrain for a self-conscious Tibetan public" (p. 333), and if so, in what ways is it constructed, maintained or constrained?

The final chapter, by editor Robert Barnett, is one of the most detailed in the entire collection. By studying a set of artistic, literary and media products pertaining to the selection of the reincarnation of the 10th Panchen Lama, the author is able to raise "questions about how modernity is currently being constructed and deployed within the political domain" (p. 353). A central component in his data set is an unusual book published in 1999 by Chen Kuiyan, the then Party Secretary of the Tibet(an) Autonomous Region, which reveals the coercive power of the state to influence public opinion. Barnett compellingly documents a "cynical realisation by the Party that the citizenry is incapable of effective response even if offered full disclosure that it has been manipulated" (p. 355). While this chapter starts out as a specific and historically contingent narrative on openness in Tibetan government messaging, it grows into a more general and profound discussion on the "fundamentally evolutionist paradigm underlying western notions of modernity and knowledge" (p. 408). By so doing, and referencing the writing of Adorno, Dean and Žižek along the way, Barnett once again illustrates the ways in which rigorous area studies scholarship can contribute to much larger theoretical and historical discussions.

In conclusion, then, both the content and the form of *Tibetan Modernities* are emblematic of elements of Tibetan modernity. To alter a popular maxim, in this diverse and interesting volume, the contributors are the message: non-Tibetans and Tibetans alike, presenting, representing and challenging some of the many features of modern communities on the plateau. I hope that a collected volume of this kind and quality may be one of the many published products of the Golden Jubilee celebration conference recently held at the Namgyal Institute of Tibetology in October 2008.

Whenever I read the phrase 'cultural and social change,' words contained in the subtitle of this collection, I am reminded of a damning comment made by the late Christoph von Fürer-Haimendorf. He remarked, almost as an aside, that it was impossible to study social change when 'one has never been there before.' In the case of *Tibetan Modernities*, though, this is no issue, as the contributors and editors are as historically well-grounded as they are theoretically well-equipped to do justice to the complexity of the subject matter. The volume heralds a new era for Tibetology, and will in no time be a core text for all scholars and students engaged with contemporary social life in Tibet.

PRINCESS PEMA TSEDEUN OF SIKKIM (1924-2008)
FOUNDER MEMBER, NAMGYAL INSTITUTE OF TIBETOLOGY¹

ANNA BALIKCI-DENJONGPA
Namgyal Institute of Tibetology

Princess of Sikkim, Pema Tsedeun Yapshi Pheunkhang Lacham Kusho, passed away in Calcutta on December 2, 2008 at the age of 84.



Princess Pema Tsedeun was born on September 6, 1924 in Darjeeling, the daughter of Sir Tashi Namgyal, K.C.S.I., K.C.I.E. (1893-1963), the eleventh Chogyal of Sikkim, and Maharani Kunzang Dechen Tshomo Namgyal, the elder daughter of Rakashar Depon Tenzing Namgyal, a General in the Tibetan Army. She was born in a world when the Himalayan Kingdom of Sikkim, established by her ancestors in the 1640s, was still a protectorate of the British Empire, and when Tibet was still ruled by the 13th Dalai Lama. Educated at St-Joseph's Convent in Kalimpong, she married Sey Kusho Gompo Tsering Yapshi Pheunkhang (1918-1973) of the family of the 11th Dalai Lama in October 1941. Her husband was the Governor of Gyantse and his

¹ Reproduced from *Now!* 20 December 2008 with some modifications.

father Sawang Chenpo Yabshi Pheuntsog khangsar Kung, was the oldest of the four Ministers of Tibet. She travelled to her husband's house in Lhasa on horseback, retreating to her palanquin when going through towns. Together, they had three daughters and a son. Lacham Kusho once related to me the circumstances of her marriage:

When I got married, my father didn't interfere. Marriage was up to me. The Pheunkhang family wanted a Sikkimese princess for their eldest son. He was 23. They wrote to the Secretary at the Palace, and I asked Barmiok Athing to reply on my behalf. I wanted to wait and go to college but they insisted that their son had to be married now. They wanted me to marry both sons as it was common in Tibet but I refused. I replied that I would only marry the eldest. Nevertheless, during the wedding, both sons were sitting next to me, but I later told my husband that I would only marry him. When I left Sikkim for Lhasa, my father gave me two maids, one bearer and two horses.

Life among the Tibetan gentry of the 1940s was pleasant. Parties, picnics and festivals succeeded themselves and although she always missed Sikkim, Pheunkhang Lacham Kusho as she was now called, spent many happy years in Tibet where her first three children were born. In Lhasa, she met a number of British, European and American visitors who spoke very highly of her in their memoirs. Heinrich Harrer was one such personality and in his book *Seven Years in Tibet* (1953: 132) describes Lacham Kusho as

She possessed the indescribable charm of Asian women and the stamp of age-old oriental culture. At the same time she was clever, well educated, and thoroughly modern, and had been taught in one of the best schools in India. She was the first woman in Tibet to refuse to marry her husband's brothers because this did not conform with her principles. In conversation she was the equal of the most intelligent woman you would be likely to meet in a European salon. She was interested in politics, culture and all that was happening in the world. She often talked about equal rights for women... but Tibet has a long way before reaching that point.

When Sangharakshita later met the Princess in Kalimpong, a hill station not far from Sikkim, he describes the encounter in *Facing Mount Kangchenjunga*

as if a beautiful and exotic butterfly had suddenly fluttered across my path. She possessed four qualities which are hardly ever found in one woman: beauty, charm, intelligence, and vitality. She possessed all of them to a higher degree than they often have when present separately. Moreover, all four qualities found expression in even her smallest

actions—whether it was the quizzical way she looked up at one from under her long lashes, or slowly exhaled the smoke of a cigarette, or murmured a few words in her low, clear, musical voice. As if these things were not enough, they were perfectly set off by the splendid costume she wore, and by the unshakeable self-confidence that came from her consciousness that royal blood flowed in her veins. The total effect was subtly devastating (1991: 30).

She often travelled the trade route back and forth between Tibet and Gangtok, sometimes accompanied by her small children bundled up in windowed boxes and carried by horse or mule. Unlike other female travellers, she rode her own horse, a rifle slung across her shoulder and a revolver in her pocket. “The route could be quite dangerous, especially from Gyantse to Phari,” Lacham Kusho recalled, “but as the caravans were well armed, people would think twice about attacking us.” The firearms she carried were not for show.

When she returned to Sikkim following China’s invasion of Tibet in the 1950s, for some ten years, she worked as the Chairman of the Sikkim Relief and Rehabilitation Committee for Tibetan Refugees funded by the Government of India. Desmond Doig recounts:

Princess Kukula, as most people call her, has an office in the corner of the palace. Sitting before a typewriter and surrounded by dozens of files, the Princess struggles valiantly to help the Tibetan refugees in Sikkim. She issues rations in a market warehouse, and squats on the palace lawn to distribute clothes. She visits the exhausted, sick, and disillusioned in a wool shed turned into a combination hospital and transit camp, and listens to refugee problems from the front seat of her jeep (*National Geographic*, March 1963: 417-18).

She also became Chairman of Sikkim’s Women Welfare Association and was a board member of the State Bank of Sikkim and Sikkim Jewels.

Her elder brother, Palden Thondup Namgyal (1923-1982) was enthroned as the twelfth Chogyal of Sikkim on April 4, 1965. When in turn, the Kingdom of Sikkim’s status as an Indian protectorate was being destabilised—events that eventually led to its merger with India in 1975—she took an active role in trying to retain Sikkim’s separate political status and unique character. As Nari Rustomji, the former Dewan of Sikkim relates: “She functioned as the Prince’s roving ambassador, whether in the corridors of power in New Delhi or socialising with the American President’s aides in Washington. She was the Prince’s chief hostess at State functions, as well as the chatelaine of his Palace” (*Sikkim: A Himalayan Tragedy*, 1987: 68), a

role which was later taken over by the Chogyal's American wife Hope Cooke. George N. Patterson, in *Peking versus Delhi* (1963: 241) talks about Lacham Kusho as

a most attractive woman, who delights to play politics after the manner of the eighteenth century women of France. Through her considerable charm and high-level friendships new factors are constantly arising from the most unexpected sources to further bedevil and obscure the already confused political and economic scene in Sikkim.

When the Namgyal Institute of Tibetology was established by the Chogyal in 1958, Lacham Kusho and her husband were among its twenty-four founder members. They donated manuscripts and a large silver plated stupa to hold the relics of two Ashokan monks, relics presented to the Institute by the Government of India in 1959. She was the last surviving founding member of the Institute and had actively participated in the Institute activities in recent years, even giving us permission to scan her photographic collection for the institute's archive so these may be preserved for posterity.

Unfortunately, she could not attend the Namgyal Institute's Golden Jubilee celebrations when an international multi-disciplinary conference was held 1-5 October 2008 with the theme *Buddhist Himalaya: Studies in Religion, History and Culture*. A total of 68 academic papers were presented by local, national and international scholars—many focusing on the history and culture of Sikkim—with foreign academic delegates coming from 16 different countries. She nevertheless contributed a message on the occasion of the Institute's Golden Jubilee and studied the conference's academic program.

My encounter with Lacham Kusho was more recent and less glamorous but the impressions she made on me were no less profound. Later in life, she was still charming and intelligent with a surprisingly excellent memory. She lived in a modest but lovely cottage on the outskirts of Gangtok, keeping up with events in Sikkim and world politics as well as her international correspondence. Forever inquisitive, she enjoyed her discussions with the scholars of Tibet and the Himalayas who invariably came knocking at her door. It was a great honour that together we celebrated the completion of my book on village religion in Sikkim with a bottle of champagne. She had never lost her spirit; may her soul rest in peace.

Lacham Kusho is survived by three of her children. The funeral took place on Wednesday December 10, 2008, at the royal cremation ground of Lukshyama in Sikkim. Rituals were held by the lamas of Pemayangtse Monastery.

TASHI T. TOPDEN, IAS (1948-2009)
DIRECTOR NAMGYAL INSTITUTE OF TIBETOLOGY 1995-2002

ANNA BALIKCI-DENJONGPA
Namgyal Institute of Tibetology

Mr Tashi Topden passed away on 6 April 2009 in a tragic car accident along with his wife Cherry, his sister Chukie and his cousin Tshering Wangchuk Barfungpa.

Tashi Topden served Sikkim as a senior bureaucrat retiring as Advisor to the Government of Sikkim in 2008. He was Director of the Namgyal Institute of Tibetology from 1995 to 2002. In spite of his responsibilities in the Finance Dept., he succeeded in expanding the research wing of the Institute.

The Libing family descends from a family of Tibetan Ngagpas called Wooja Lingpa. Their ancestor known as Akhoola came to Sikkim some two and half centuries ago and served the Chogyal. The famous Trokhang Dronyer Namgyal, better known as Dewan Namgyal or Pagla Dewan, was the younger brother of Tashi Topden's great grandfather Labrang Dewan Rinzing or Nyim Tenzin. Dewan Namgyal became the Chief Minister of the 7th Chogyal Tsugphud Namgyal in 1847. Despite his exile to Tibet imposed by the Treaty of Tumlong in 1861, Dewan Namgyal remained very influential in Sikkimese affairs until his death in 1888.

Tashi Topden's father Rai Bahadur Sonam Topden chose modern English schooling and entered the British service in 1925. In 1947, he opted for the service of India and retired in 1959 as an honoured member of the Indian Foreign Service.

In line with his father's preferences, Tashi Topden was educated at St-Joseph's school in Darjeeling. He graduated in 1969 with a BA (Hon) in History from St-Stephen's College, Delhi University, and received his L.L.B. from Bombay University in 1971. He then went on for IAS training at the Lal Bahadur Shastri National Academy of Administration, Mussorie.

He started his career in the Govt of Sikkim as Deputy District Officer-cum-Planning Officer, South District at Namchi in Sept 1974. He then took charge of the office of the District Collector West Sikkim in 1976 and eventually of the East District in 1978 with the additional charges of District Magistrate and Administrator of the Gangtok

Municipal Corporation in 1981. He was promoted to the Finance Dept. as Joint Secretary in 1983 and then joined the Establishment Dept. as Joint Secretary in 1986. He was promoted to Secretary Industries and Secretary Education and Cultural Affairs in 1986, and then onto Commissioner-cum-Secretary Dept. of Food and Civil Supplies in 1991. He was transferred to the Finance Dept. in 1993 where he was promoted to Principal Secretary Finance in 1999. He was again promoted to Additional Chief Secretary and Secretary Health and Family Welfare in 2001 and transferred in 2002 to Additional Chief Secretary and Secretary Land Revenue Dept. Eventually promoted to Advisor to the Government in 2003, he retired from government service in 2008.

Tashi Topden was also deeply interested in the study of Sikkim's social history and culture. He had recently established the Denzong Lhomen Kyiduk (Sikkimese Culture and Heritage Foundation) with the hope of promoting all aspects of Sikkimese religion and culture. As stated in an obituary published in the Foundation's first book (P.T Gyamtso *Denjong Sunglu*, 2009), Tashi Topden

spend many long hours talking to Sikkimese people in all walks of life, trying to gain an insight into the religious rituals and local Sikkimese customs. While serving with the Government of Sikkim he used his considerable abilities to renovate and restore many Sikkimese monasteries as a way of promoting Sikkimese culture.

He also derived much pleasure and knowledge as an amateur historian and from his association with the Namgyal Institute of Tibetology in Gangtok. There he met many local and foreign scholars from whom he increased his knowledge and deepened his insight into Sikkimese Culture.

Tashi Topden is survived by a son Tashi Norbu and a daughter Chimey Zangmo.

NOTES ON CONTRIBUTORS

FRANZ-KARL EHRHARD is Professor of Tibetan and Buddhist Studies at the University of Munich, Germany. His research work centres on religious and literary traditions in Tibet and the Himalayas. His latest publication is *A Rosary of Rubies: The Chronicle of the Gur-rigs mDo-chen Tradition from South-Western Tibet* (Collectanea Himalayica, 2). Munich: Indus Verlag, 2008.

MÉLANIE VANDENHELSEN is a Doctor in anthropology from the University of Montpellier, France. Her dissertation is entitled: *The Buddhist Monastery of Pemayangtse in Sikkim (Oriental Himalayas, India): a Monastery in the World* (completed under the direction of Professor Brigitte Steinmann). She is presently lecturer in the University of Lille 1 (North of France). She has authored two previous articles on Pemayangtse and Tashiding monasteries in the *Bulletin of Tibetology*: Vol. 39 (1) and (with Hissey Wongchuk) Vol. 42 (1&2).

P.K. GAUTAM is a former officer of the Indian Army. In August 2005 he joined the Institute for Defence Studies and Analyses as a Research Fellow. His present interests are environment, Himalayan ecology, Buddhism, Tibet, composition of the army and trends in warfare. He has authored a number of books and contributed chapters to edited volumes. *Environmental Security: New Challenges and Role of Military* (2010: Shipra Publishers) is his latest book. He has also contributed chapters in IDSA Working Group Report *Security Implications of Climate Change for India* (2009) published by Academic Foundation.

SONAM WANGDI is a retired IAS officer and a former Chief Secretary to the Government of Sikkim. An alumnus of the London School of Economics and Life Member of LSE Society, Sonam Wangdi holds an M.Sc. from London University. He developed an interest in Tibet in the 1960s when he met the Founder-Director, Namgyal Institute of Tibetology, N.C. Sinha. In 1968, the Tibetan Review published his *Tibet Today: A Nation in Chains*. The present article succinctly discusses Tibet since 1968. He was Rehabilitation Officer for Tibetan Refugees in Sikkim from 1966 to 1969.

JENNY BENTLEY is a doctorate student in cultural anthropology at the University of Zürich. Her present research centres on the Lepcha community rituals, their meaning in constructing collective identity and their adaptations to the changing Sikkimese context. She previously studied the cultural revival among the Sikkimese Lepcha during her master's degree program at the University of Zürich and the University of Delhi, where she was admitted as a casual student. She is at present affiliated to the Namgyal Institute of Tibetology and conducting fieldwork in Sikkim and Kalimpong.

PEMA WANGCHUK DORJEE is a Gangtok-based journalist and has been reporting on Sikkim for the past 14 years. He is the editor of NOW! daily and has worked in the past with Himal (Kathmandu), Sikkim Observer and Weekend Review. *Khangchendzonga: Sacred Summit*, a book co-authored by him with Mita Zulca was released in March 2007.

DR P.W. SAMDUP was born in 1936 in Darjeeling to T.T. Samdup. He completed his MBBS from Assam Medical College in 1961, and his MPH from Hawaii University in 1989. From 1963 to 1985, he served in the Royal Government of Bhutan in various capacities, the last as Superintendent of Health Services. During his tenure in the government, he also served as one of the physicians to His Majesty the Third King of Bhutan. During the same time His Majesty the King honoured him with the red scarf, and the title of 'Dasho'. From 1985 to 1996, Dr Samdup worked in the WHO, seven years of which he lived in Sri Lanka where he was able to visit the temples and statues dedicated to Kazi Dawa Samdup's brother Reverend S Mahinda Thero.

JOHN BRAY is an independent scholar, currently based in Kumamoto, Japan. His research interests include the history of the Himalayan border areas, particularly Ladakh and Sikkim, and the history of missionary engagement with Tibet. His recent publications include papers in the Journal of the Royal Asiatic Society and Zentralasiatische Studien as well as two edited collections: *Recent Research on Ladakh 2009* (co-edited with Monisha Ahmed, Kargil and Leh, 2009), and *Mountains, Monasteries and Mosques* (co-edited with Elena de Rossi Filibeck, Rome, 2009). He is President of the International Association of Ladakh Studies (IALS – www.ladakhstudies.org).

SAUL MULLARD completed his doctorate from the University of Oxford (Oriental Institute) in Tibetan and Himalayan Studies. His thesis was titled *Opening the Hidden Land: State formation and the construction of Sikkimese history*. He is currently holder of a Leverhulme grant for a period of two years and is working in collaboration with the Namgyal Institute of Tibetology on a project involving rare Sikkimese manuscripts. He is the author of numerous articles on early Sikkimese history and is a regular contributor to the *Bulletin of Tibetology*.

ANNA BALIKCI-DENJONGPA is the Research Coordinator at the Namgyal Institute of Tibetology and Editor of the *Bulletin of Tibetology*. She received her Ph.D. in Social Anthropology from the School of Oriental and African Studies, London University, which was recently published as *Lamas, Shamans and Ancestors: Village Religion in Sikkim* (Brill, 2008). She is currently supervising a research project on the social history of Sikkimese society through the use of historic photographs and a visual anthropology project aiming to document the social life and rituals of the Sikkimese Bhutias and Lepchas.

ALEX MCKAY has a BA (Hons) and a PhD (1997) from the School of Oriental and African Studies, London University. He has held research and teaching posts at London University (SOAS and UCL) and in Leiden (International Institute for Asian Studies). His publications include *Tibet and the British Raj: The Frontier Cadre 1904-1947* (London 1997, 2nd edition by LTWA Dharamsala 2009), *Footprints Remain: Biomedical Beginnings Across the Indo-Tibetan Frontier 1870-1970* (University of Amsterdam 2007) and a 3 volume edited work, *The History of Tibet* (London 2003).

MARK TURIN is a linguistic anthropologist. He studied archaeology and anthropology at the University of Cambridge, and holds a PhD in descriptive linguistics from Leiden University. He has held research appointments at Cornell and Leipzig universities. From 2007 to 2008, he was Chief of Translation and Interpretation at the United Nations Mission in Nepal (UNMIN). At present, he continues to direct the Digital Himalaya Project which he co-founded in 2000, and recently established the World Oral Literature Project, an urgent global initiative to document and make accessible endangered oral literatures before they disappear without record.

CORRIGENDA

In *the Bulletin of Tibetology* Vol. 42 (1 and 2) in the article *Tibetan masters and the formation of the sacred site of Tashiding* some points were overlooked by the authors Mélanie Vandenhelsken and Hissey Wongchuk which were later discovered and discussed by all authors involved. The results of these discussions are the following corrections:

Page 76, fn 60 should begin with: *As Mullard has already mentioned (2005b, p.37, fn 18),*

Page 77, fn 61 should have included reference to Mullard 2005b, p. 39, fn 30, and fn 62 should have included reference to Mullard 2005a, p.76, fn 68.

Page 79, fn 76 should have mentioned that the transliteration given in that footnote and the translation (on the same page) had also been made by Saul Mullard.

ANNOUNCEMENT: *EMSCAT*

Founded in 1970, *Études mongoles et sibériennes, centrasiatiques et tibétaines (EMSCAT)* is the oldest currently published journal dealing with the Mongol world and surrounding areas in western Asia. In 1976, *EMSCAT* expanded its coverage to include Siberia, and in 2004, Central Asia and Tibet. It is *EMSCAT*'s intention to provide a forum for scholarship on cultural issues by both established scholars and young researchers new to the field. The editorial line encompasses regular issues, monographs, and comparative thematic issues often produced by guest editors. The journal is published annually.

From now on, *EMSCAT* will appear solely in an on-line format. *EMSCAT* is hosted by Revues.org, the federation of on-line journals concerning the social and human sciences. Several back issues of *EMSCAT* are already freely available online, while the others are slated for release in the coming year. There is a three-year moving wall between the publication date of the most recent issue (n° 38-39, 2008) and when it will appear on-line. For access to the journal please visit: <http://emscat.revues.org>

We hope you will enjoy reading the volumes 32; 35 and 36-37.

The Editorial Board