

NARRATIONS ABOUT A YOGĪ IN SIKKIM<sup>1</sup>

MÉLANIE VANDENHELSEN  
*Namgyal Institute of Tibetology*

Chathak Rinpoche (lCags thag Rin po che) was a Tibetan yogī who lived from the end of the nineteenth century until 1958. His name literally means ‘iron cord’ and was given after the iron chains he used to wear around his chest. He came to Sikkim at the beginning of the twentieth century, while living the life of a wandering yogī. He spent around fifty years in Sikkim mainly in the village of sGang rgyab, near Zil gnon in West Sikkim, with his Lepcha wife and his children.

The following information on Chathak Rinpoche comes from several members of his family. As most of Chathak Rinpoche’s children are deceased (except the youngest son and two daughters), more distant relatives have been interviewed. These informants’ relationships to Rinpoche are shown in a family tree (see Annexe 1) in which they appear in black.

The informants often gave different versions of the same event. Chathak Rinpoche’s life story indeed belongs to the rich tradition of oral history and as such is subject to variations. To preserve this specificity of non-written history, I will here consider the collected data as narrations. This article is thus more about the actual interpretations of Rinpoche’s deeds than a historical work. This stand relies on these methods:

1) Describing the conditions of knowledge: how did the informants obtain their information? The informants’ names are not given here because their reliability does not depend on who they are but on their relationship to Rinpoche.

---

<sup>1</sup> Thank you to the informants who provided the material for this article, namely, Pema Diki from sGang rgyab, Chota Ajo, Palchen Dorje Chatak, Namgyal Tshering Chatak, Lophon Tempa Gyatso, Namkha Gyaltzen, Yabchung Bhutia, Dawa Gyatso Bhutia, Phurpo Tshering Bhutia, Palphun Yongda and Tshering Wangchuk Barphungpa. Thank you to Tashi Densapa, Jenny Bentley, Kakoli Chaudhuri, Vikash Pradhan and Palchen Dorje Chatak for their corrections and comments—the possible mistakes remain mine—and to Yeshe Wangchuk, Namgyal Institute of Tibetology, who assisted me during this research and translated the interviews from *lho skad* into English.

2) Relating all different versions without attempting to identify any as the truthful representation of historical facts. This method has two advantages: to reveal the information, which appears most frequently and is therefore the one which can most probably be considered as factual; and to identify themes in the narration.

3) Considering that the narration is a construction based on real facts and themes of thought (coming from other narratives, scriptures, etc.) and attempting to identify the latter.

While the informants will be introduced in the first part, the second part will describe the different versions of Chathak Rinpoche's life highlighting themes which appear in the accounts.

- Informant 1 is the widow of Chathak Rinpoche's second son. She lives in sGang rgyab and was interviewed in Gangtok in the presence of her grandson (informant 7). She was born in the Earth Snake year of 1929 and is now 79. After marriage, she moved into Rinpoche's house when he was still alive. She was close to her mother-in-law (with whom she lived for twelve years, before and after Rinpoche's death) from whom she obtained her information about Chathak Rinpoche (as we will see below, Rinpoche did not talk much about himself). She is also close to Chathak Rinpoche's second daughter with whom she still shares stories about Rinpoche. She obtained additional information from her own mother who came from Zil gnon near sGang rgyab. Her grandson (informant 7) also answered my questions while working on this paper.

- Informant 2 is the brother-in-law of Chathak Rinpoche's youngest son. He lives in Zil gnon where he was interviewed and is about 75 years old. He regularly met with Chathak Rinpoche, notably in the days preceding Rinpoche's death.

- Informant 3 is the youngest son of Chathak Rinpoche's second son. More than an informant, he was our guide during our visit to his grandfather's village.

- Informant 4 is the nephew of informant 1 and is about 50 years old. He obtained his information from his father, to whom Chathak Rinpoche was the 'root spiritual master' (Tib. *rtsa ba'i bla ma*).<sup>2</sup> Informant 4's father was originally from Zil gnon. He was a close friend of Chathak Rinpoche's eldest son, known in Sikkim as sGang rgyab 'mTshams po Rinpoche, and died in the summer of 2006.

- Informants 5 and 6 are the sons of Chathak Rinpoche's youngest daughter, who, with her sister, married the same man from Ra lang.

---

<sup>2</sup> The mention 'Tib.' indicates words in Tibetan transliterated with the Wylie system.

The eldest son, informant 5, was interviewed several times in Gangtok where he resides. He obtained his primary knowledge on Chathak Rinpoche from his own father and, as he is himself carrying out research on Rinpoche, has also collected information from various sources. His brother, informant 6, was interviewed in Ra lang, where he resides with his mother and her sister. Due to poor health, both daughters could not be interviewed but the son, informant 6, narrated whatever information he had heard from them.

- Informant 8 has also devoted time to gathering information on Chathak Rinpoche. He was close to his mother-in-law and to informant 1's mother from whom he collected information. He was interviewed in Gangtok in the presence of his half-brothers-in-laws, informants 9 and 10. Informant 10 also answered my questions, mainly concerning his family, all along the preparation of this work.

#### VERSIONS OF CHATHAK RINPOCHE'S LIFE

##### *His origin*

Chathak Rinpoche was born in the Water Sheep year of 1883 (informant 4). Informant 8 gives the year of 1870 however, without knowing the Tibetan year. Rinpoche's name was Padma gling 'phro' (see Tibetan text in Annexe 2). Several informants mentioned that he was from a higher class (informant 6) or even the son of a royal family (informants 1 and 2); according to informant 5, he was the son of a provincial chieftain named Bya dral rGyal po. He had at least one brother who came to visit him in Mangthiang, which is the hamlet of sGang rgyab where he lived with his wife (informants 1 and 4).

According to most informants, Rinpoche was born in the north-eastern Tibetan province of mGo log (informant 1, 4 and 5).<sup>3</sup> Before 1950, the region of mGo log was in south-eastern A mdo (see map below), bordering on northern Khams;<sup>4</sup> it is located on the south-eastern slopes of the A myes ma chen range, which is now in the Chinese province of Qinghai. According to informant 1, g.Yang thang Rinpoche<sup>5</sup> built a monastery in Chathak Rinpoche's place of origin in

<sup>3</sup> He was born in a place named 'Dotrapu' according to informant 8, but no detail could be found about this place.

<sup>4</sup> The southern part of mGo log was in Khams but the capital, Machu, was in A mdo.

<sup>5</sup> The person most commonly known in Sikkim as g.Yang thang Rin po che is actually gTer ston rDo rje bde chen gling pa, also known as mDo mang Rinpoche and incarnation of mDo mang gTer ston. His religious lineage is originally from Khams. He is believed to be the incarnation of lHa btsun chen po.

Tibet. Informant 1 asked g.Yang thang Rinpoche’s niece to describe the place and was told that it is a high altitude mountainous area.

It is interesting to note that all of these informants locate mGo log in Khams and according to two others (2 and 6), Chathak Rinpoche said he was born in Khams Mi nyag, which is around 200 miles

**Map of Tibet before 1914<sup>6</sup>**

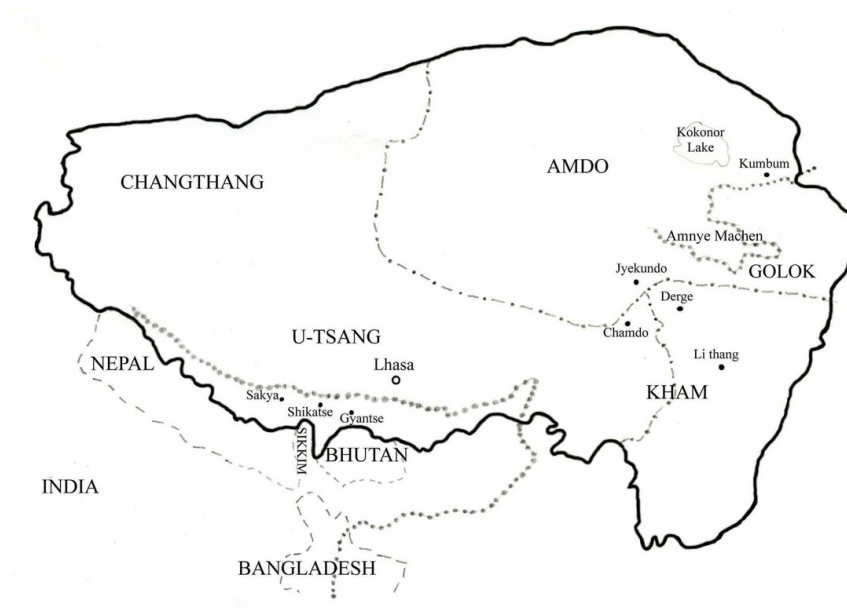

- Tibetan boundary
- Old provincial boundary
- International boundary
- ..... Rivers

southward near Li thang.<sup>7</sup> Khams Min yag was the place of origin of Gyad ’bum bsags, the ancestor of the Sikkimese Chogyals and of the major Lho po clans according to one of the versions of the origin of the

<sup>6</sup> Based on <http://omni.cc.purdue.edu/~wtv/tibet/map.html>

<sup>7</sup> See R.A. Stein, 1951.

Namgyal dynasty.<sup>8</sup> To assign the origin of Chathak Rinpoche to Khams and particularly to Khams Mi nyag further contributed to his and his family's high social status. Rinpoche's origin together with his own prestige have succeeded in conferring a high status to his family; almost all of its members have married Lho po spouses. Moreover, several members of the family are addressed as 'yab,' which is a title of high social status in Sikkim.<sup>9</sup>

*His lineage of incarnation*

Chathak Rinpoche was the 16<sup>th</sup> incarnation (or 13<sup>th</sup> according to informant 7) of a lineage of *sgrub thob* or siddha, i.e. 'accomplished ones' (informant 6). All informants give the same names for his previous incarnations, but the order varies (again see the text in Annexe 2). The founder of the lineage was an Indian siddha called Saraha. The biography of Saraha found in the web site of the Dharma Fellowship of His Holiness the rGyal ba Karmapa<sup>10</sup> reads as follows:

Acclaimed one of the greatest yogis of India in the late 8th century, the indomitable Saraha heads the Mahamudra lineage. He was born into a Brahmin class family in Bengal, eastern India.

The text then explains how Saraha, though raised to become a Buddhist monk (at that time, the Pala dynasty of Bengal was promoting Buddhism), was expelled from his monastery because he broke the rule; he then became a wandering yogī. Afterwards,

He became the disciple of a saint named Ratnamati, who was a master of the *Guhyasamaj Tantra*. Thus Saraha learnt the profound secrets of a method of meditation that focuses on raising *kundalini* [...] and abiding in blissful Mind's own innate state.

He eventually met a woman who became his wife and to support his family, he took up the craft of making arrows. The very name 'Saraha' is derived from his occupation as a maker of arrow. The text continues:

Saraha begins the lineage which descends through his disciple Savari to Luipada, to Dengri, Vajraghanta, Kambala, Jalandhara, Krsnacarya,

---

<sup>8</sup> According to another version, Gyad 'bum bsags originated from the northern Mi nyag, also called Si-hia (or Xixia), located near to the Kokonor lake in Tibet. See mThu stobs rnam rgyal and Ye shes sgröl ma, 1908.

<sup>9</sup> The etymology of the word is unclear. In Tibetan, 'yab' is the honorific term meaning 'father.' It could have become a title in Sikkim, making paternity a metaphor of superiority. But it could also be a contraction of 'yar pa' or 'above ones.' 'Yab' most frequently applies to the landlords (kazi) and to high lamas.

<sup>10</sup> <http://www.dharmafellowship.org/biographies/historicalsaints/saraha.htm>

Vijayapada, to Tilopa and Naropa, the teachers of Marpa of Lhotrak. Marpa was the renowned teacher of Tibet's greatest yogi Milarepa, and the latter taught Gampopa, who in turn was the teacher of the first Karmapa. Today, the Karmapa is the living custodian of this Mahamudra meditation lineage.

According to the text given in Annexe 2, "In [his] second [life], Chathak Rinpoche incarnated in Maha guru bSod nams rin chen (also called Ma ni bSod nams rin chen) or sGrub chen Thang stong rgyal po." As this sentence suggests and as informant 5 believes, bSod nams rin chen could be another name for Thang stong rgyal po. However, Cyrus Stearns who recently published a book on Thang stong rgyal po (2007) has never heard of this name being used for him, nor does he know any special connection between Thang stong rgyal po and Saraha.<sup>11</sup> According to most informants, Ma ni bSod nams rin chen was the previous incarnation of Chathak Rinpoche.

Thang stong rgyal po was born in La stod (western Tibet) in the second half of the 14<sup>th</sup> century.<sup>12</sup> "He is of course famous for his engineering feat of constructing iron chain suspension bridges over gorges and rivers in the many regions he visited. He was also the first to open up the region of the barbaric kLo-pas in Kong-po. He constructed auspicious stūpas and temples at key geomantical spots to ward off both evil forces and real menace of the Hor-pa tribes. He is connected with the origin of the Tibetan drama tradition and the monastic orchestra."<sup>13</sup> He also discovered many *gter ma* and initiated major lineages but there is no unanimity as to which school he belonged, being variously claimed as rNying ma pa, bKa' brgyud pa and Sa skya pa.<sup>14</sup> According to Samuel,<sup>15</sup> his links are more with the 'Shangpa Kagyupa' than with the rNying ma pa;

This small Kagyüdpā tradition, which claimed to go back to Ky'ungpo Neljor and the teaching of Niguma, Nāropa's sister or consort, rather than to Marpa and Nāropa, was one of the Kagyüdpā yogic traditions that continued to exist quietly alongside the large monastic *gompa* of Karmapa, Drugpa, and Drigungpa.

---

<sup>11</sup> Personal communication.

<sup>12</sup> There is no unanimity concerning his dates; he could have been born in 1385, 1361 or 1421 and died in 1464, 1459, 1485, 1510 or 1519 (see Stein, 1981: 53 and 267 n72, Samuel 1993: 518 and C. Stearns 2007).

<sup>13</sup> Gyatso, 1979: 111.

<sup>14</sup> *Ibid.*

<sup>15</sup> 1993: 518.

According to informants 1 and 8, Chathak Rinpoche also incarnated as gLing Ge sar. Ge sar was the hero of the Tibetan epic, who became king of gLing, a country which existed from at least the end of the 14<sup>th</sup> century.<sup>16</sup> He is the founding ancestor of the people of Khams, “a culture-hero who defeated the demonic or non-Buddhist kings of the four directions and ruled over all of east Tibet.”<sup>17</sup> He was indeed a “tamer,” both of demons and hostile forces in general, and of men.<sup>18</sup> Ge sar is also one of the “trickster-like figures” whose activities are frequently devious and treacherous according to the rules of ordinary morality, but always legitimated by a higher spiritual purpose.<sup>19</sup>

The link between Chathak Rinpoche’s previous incarnations is uncertain. A connection to the Karmapa and the bKa’ brgyud pa schools of Buddhism is established with Saraha and Thang stong rgyal po. But he cannot be located in one particular monastic lineage. The links with his previous incarnations are elsewhere: as we will see, several of these previous incarnations’ characteristics emerge from the narrations on Chathak Rinpoche, such as his distance from the monastic institution and his activities as a ‘tamer’ of demons.

*Chathak Rinpoche’s relationships to the monastic institution*

Chathak Rinpoche was a *sgrub thob* or ‘accomplished one’, which is defined in Sikkim as a religious specialist who does not have to follow the rules of life that apply to the members of the Buddhist religious community (Skt. *vinaya*, Tib. *'dul ba*). But, according to informant 4, who is a lama, Chathak Rinpoche studied in a rNying ma pa rDzogs chen monastery in mGo log where he practiced *rtsa rlung* or anu yoga, which leads to the control of the internal channels and vital energies. Though other members of his family agree that Rinpoche was an accomplished practitioner of *rtsa rlung*—which explains why he had to wear chains around his body (to prevent himself from flying) and how he could walk extraordinarily fast<sup>20</sup>—they stress his distance from monastic practices.

Informant 1, for instance, explains that at a young age, Chathak Rinpoche was staying in a monastery, but once ran away with a white

---

<sup>16</sup> See Stein, 1981: 243-245.

<sup>17</sup> Samuel, 1993: 68-69.

<sup>18</sup> *Ibid.*: 572.

<sup>19</sup> *Ibid.*: 214. Concerning the Ge sar epic, see also Samuel, *ibid.*: 166, 540, 564 and 293-294.

<sup>20</sup> A common hearsay is that Chagthak Rinpoche was wearing chains to control his extraordinary power; he would have fallen into trance or become demonic if not.

goat. He was eventually caught and brought back. According to informant 6, it was from his house that Rinpoche ran away with a white goat when he was a child. An informant from Phodong, not related to Chathak Rinpoche, asserted that her grandmother once met Rinpoche meditating on a rock and asked him to come pray for a funeral. Rinpoche replied that he could not enter any house, but he would pray from outside for the deceased.<sup>21</sup>

Informant 1 adds that Rinpoche neither received nor bestowed any empowerments (Tib. *dbang*) or transmissions (Tib. *lung*). He also did not wear any monastic garments, but only covered himself with a leopard skin around the waist. “He was bound under oath to the gods and demons,” she explains. These accounts aim at showing that Chathak Rinpoche was a natural *sgrub thob*. As such, he had the urge to leave the monastery as well as his family to live the life of a wanderer. Monastery and family are here seen as stable and comfortable institutions which would have hindered the wandering life necessary to tame demons.

Another feature that demonstrates his difference from lamas is his discretion because “His intention was to liberate beings, not to teach them; he had the power to liberate corpses and living beings’ consciousnesses” explains informant 6. He was generally very discrete, not talking about himself and his powers. According to informant 7, this was not only a feature of his character but also a promise Rinpoche had made. The latter indeed was often repeated: “I’m not supposed to reveal what I am doing.” Informant 6 adds that Rinpoche’s discretion has become a feature of his descendants. Indeed, “It is said that they are all bodhisattvas. They never show off, never talk. They want to be left alone and contemplate in compassion. They have nothing to do with monasteries.”

Rinpoche used to read only one Tibetan religious text, the *rDo rje gcod pa* or ‘Diamond sutra,’ using a small hand ritual drum (*da ma ru*) and a ritual bell, but he did not perform rituals for donors (Tib. *mchod gnas*, i.e. ‘preceptor-donor’ relationship). Though the narrations concerning him display some of the ‘crazy siddha’s’ unusual behaviour—his half nakedness and his appearance, and probably his marriage with a Lepcha villager, which might have been uncommon for Tibetans a hundred years ago—they also show his respect for monasteries. Indeed, Chathak Rinpoche built a *tsa khang* or ‘house for clay icons of a deity’ (Tib. *tsa tsa*) in bKra shis sdings (Tashiding) and

---

<sup>21</sup> In Sikkim, other lamas, even more involved into the monastic institution, never attend funerals.



once said to informant 4's father that Padma g.yang rtse (Pemayangtse) was a particularly holy place. But there is no ambiguity in these relationships to monastic institutions. Indeed, his distance from monastic institutions does not prevent a deep faith and the recognition of monasteries as centres of Buddhist practice and development. Monastic life was simply not the one he had to follow.

#### *Rinpoche's life in Tibet*

Though most informants agree that Chathak Rinpoche hardly talked about his life in Tibet prior to his first visit to Sikkim, informant 5 has information on this period of Chathak Rinpoche's life. He said that Rinpoche used to perform rituals and meditate in cremation grounds and was able to see the divine owners of the cemeteries (Tib. *dur khrod bdag po*). In Tibet, Rinpoche competed with a famous monk of the area who, after hearing about his powers, wanted to challenge him. Both men then decided to spend a night in the cold water of a nearby lake to see which of them would be able to remain the longest. On a specific date, they entered the water witnessed by an esteemed crowd. After a few hours the monk collapsed. He had to be dragged out of the water and resuscitated with the heat of blankets and tea. But Chathak Rinpoche stayed in the water until morning. The next day, the monk came to meet him, apologized and recognized Rinpoche's religious superiority. This story suggests that Rinpoche was a '*ras pa*,' i.e. one who controls his inner fire and can raise his inner heat, a technique of which Mi la ras pa was a famous adept. Still according to informant 5, Chathak Rinpoche recognised his first son as an incarnation of one of Mi la ras pa's disciples.<sup>22</sup> These narrations probably aim at ascertaining Chathak Rinpoche's connection to sGrub thob Saraha.

#### *Beginnings in Sikkim*

Chathak Rinpoche's arrival in Sikkim follows his successful escape from his home and the monastery (informant 1). The precise date of his arrival in Sikkim is unknown. It was around the year 1900 according to informants 5 and 8 (for whom, Rinpoche was then 30 years old, believing he was born in 1870). Rinpoche was also 30 years old according to informant 4, but 18 to 20 years old according to informant 7, and 25 according to informant 6. This latter informant adds that Rinpoche told his wife he was 25 years old when he met her for the

---

<sup>22</sup> It would be of Mi la ras pa's master, i.e. Mar pa, according to informant 7.

first time. In any case, Rinpoche arrived before 1910 (Iron Dog year) since his first son was born that year in Tibet, where he returned with his wife after having met her in Sikkim. According to informant 1, a war between the British and the Tibetans was being waged when Rinpoche arrived in Sikkim; it was most probably the 1903-04 war, which broke out due to the Younghusband mission to Lhasa. Assuming that Chathak Rinpoche was born in 1883, he was 20 or 21 years old when he arrived in Sikkim in 1903 or 1904.

The order of the places he visited in Sikkim also varies depending on the informants. For most of them (informants 1, 2, 4, 6 and 8), Rinpoche first went to Phodong after arriving from Chumbi via Lachung. At that time, his feet would not touch the ground—he was in a state of permanent levitation—because of his achievements in yogic practices. Therefore, he built a *mchod rten* (stūpa), filled it with precious objects and, tied a rope at each corner which he planted in the soil. He was then able to walk on the ground (informants 1 and 4). Nevertheless, he continued to wear chains around his body.

His uncommon appearance is described in a story which would have occurred in the Phodong area (informants 5 and 6). Informant 5 describes the incident as follows:

On his way to the consecration of one *mchod rten*, Chathak Rinpoche met two hunters. One of them was the Raj Kumar and the other was Rhenock Athing.<sup>23</sup> Rinpoche came out of a bush so suddenly that the two hunters got scared and did not think that this being, who wearing only a leopard skin around his waist and chains on his chest, was human. They pointed their guns toward Rinpoche and asked, ‘Are you a ghost?’ Rinpoche answered he was a human and the prince understood he had miraculous powers.

#### *The wandering demons’ tamer*

Chathak Rinpoche then spent some time wandering from place to place. The names of these places—which vary depending on informants—can be considered as tangible testimony of Rinpoche’s power to subdue and liberate demons. Doing so, Chathak Rinpoche proved ’Bras ljongs’s (Sikkim’s) sanctity and added his own blessing to it.

---

<sup>23</sup> The prince mentioned here was most probably Prince Paljor (1921-1941) who was Chogyal Tashi Namgyal’s eldest son. Rhenock Athing (Sonam Dadul) was the chief steward of the palace and was a famous hunter. Later on, in the 1950s, his eldest son (Tse Ten Tashi) took the only photo of lCags thag Rin po che. Thank you to Tshering Wangchuk Barphungpa for this information.

Rinpoche went to Sing gtam (Singtam), to a place called Shing chu thang, to Theg mchog yang rtse (Thekcho Yantse) above gSang sngags chos gling (Sangacholing), to bDe chen phug where he meditated, to rGyal ba (Gyewa) near rGyal shing, to Grub sde (Dubdi), to mKha' spyod dpal ri (Kechuperi), to gSang gnas me 'bar phug (Sangne Mebar phug) via rDo rje 'Pham, to Zil snyan (Sinek) and bKra shis sding (informant 4). He stayed in the Sa skyong area near rGyal shing for almost a year (informant 6); he went to Nam rtse (Namchi) and stayed in Yang rtse, below Rab gdan rtse (Rabdentse), for many years (informant 8).

Wherever he went, he used to put up several tents even though he was alone (informant 4). In Phodong (informant 2) as well as in Zil gnon (informant 1), he put up seven tents, each of a different colour. In each he kept a shrine (Tib. *dkyil 'khor*) for offerings to the deities. Informant 1's mother saw the tents in Zil gnon and noticed that Rinpoche was not sleeping in any of them at night nor was he seen in them during the day. The informants here suggest that he was playing host to a retinue of deities, invisible to normal beings, while he himself was engaged in secret activities.

His activity was most likely the taming of demons and liberating beings as he did in the Singtam area (informant 4). Here, he saw a tree entirely wrapped by climbing parasite plants. He cut the climbing plants and offered it to the deities to remove their negative deeds, threw it in different directions, and then shot an arrow in each direction. In doing so, he liberated the tree. Informant 4 also tells that one day, his father and Chathak Rinpoche's second son caught some frogs. They hung the animals from the window of a house. When Rinpoche saw them, he said, "these animals suffer the consequences of their bad deeds", and started to pray facing Gangs chen mdzod lnga. In the evening, Chathak Rinpoche released the frogs into the river Rinjan Kyiong. Early the next morning, he prayed again and in the evening of the same day, a heavy rain fell and all the frogs disappeared from the river. "We can say that the frogs have been swept away by the flood or that they have gone to heaven. Even now, frogs are rarely seen in this river," comments informant 4.

Chathak Rinpoche devoted an important part of his life to building *mchod rten* with different intentions. In Tibet (informant 6), he built one for protection against war (Tib. *dmag zlog*). But most of the time, the *mchod rten* were intended to 'exorcise' or 'tame' the local deities (Tib. *bzlog thabs*) as was the case of the *mchod rten* built at Tenth Mile

in Kalimpong<sup>24</sup> on a land donated by a Bhutanese queen. Eight of them were built in Mangthiang (probably ‘Moong phyang’ in Lepcha) where he resided with his wife and children (informant 5). The latter can still be seen today in the forest near to Chathak Rinpoche’s old house around forty-five minutes walk below sGang rgyab. Near one of them is a ‘house for the serpent spirits’ (Tib. *klu bum*), also made by Rinpoche. Rinpoche built Mangthiang *mchod rten* at night and refused any help. Because the construction was very fast nevertheless, it is believed that he received supernatural support (informant 5).

Rinpoche also built the *mchod rten* in the market place in rGyal shing and the ‘*ma ni* wall’ going from the *mchod rten* to the Ma ni lha khang down the road bordering the taxi stand. According to informant 4, he made these buildings to remove obstacles for Sikkim that will originate in rGyal shing. Informant 4 comments that the events of 1973 indeed started from this place. This comment aims to demonstrate Chathak Rinpoche’s visionary power that I will mention again below.

According to informant 5, Chathak Rinpoche used to leave rings of his chains—made of different precious metals—in the *mchod rten* he was building in order to bless the place and transmit to it the force of protection given to the object by contact with his body.

Another realisation of Rinpoche can be seen in Zil gnon. Near the monastery are three raised stones facing each other and representing ‘thrones’ (Tib. *khri*). On one of these thrones, Chathak Rinpoche carved the outlines of Ma ni bSod nams rin chen with crossed legs, holding a prayer wheel (*ma ni*) in his right hand, what appears to be a bone trumpet (Tib. *rkang gling*) in the left, and a strap on his chest. The second one is a long rectangular stone on which ‘Om a’ hum’ is carved and the third one is apparently not carved but, according to informant 2, bears the natural carving of Kun tu bzang po. Other informants agree saying that it is no longer possible to know what the last two stones exactly represent. Informants 2 and 6 explain that Rinpoche’s intention whilst making these thrones was to create auspiciousness for the future (Tib. *rten ’brel*). Informant 1 said that when the time came to consecrate the thrones, Chathak Rinpoche searched for two girls to sit on them, representing or being *dākinī* (Tib. *mkha’ ’gro*). He found one of them, but the second, who was informant 1’s mother, could not come. This anecdote explains why the meaning of Rinpoche’s realisation was not transmitted to his family. Rinpoche consecrated the thrones with only one girl.

---

<sup>24</sup> This *mchod rten* was destroyed but there are photos of it.

Chathak Rinpoche's thrones in Zil gnon have recently been restored and a shed to cover them is under construction. A concrete support has been built to hold up the stones and interestingly, Ma ni bSod nams rin chen's outlines have been replaced by a more figurative painting. The character's features now clearly appear, seated crossed legged with a mountain in the background. He bears a leopard skin around his waist, still holds a *ma ni* in his right hand and a bone trumpet in the left. The strap on his chest now holds a quiver, adding to his character as a demon's tamer.

Another of Rinpoche's accomplishments in terms of taming evil spirits are the raised stones of Srin 'dzom (Sinzom) or Srin mo 'dzom ('gathering place of the ogresses') on the way to Zil gnon. The story of this place was recounted in the newspaper by Dawa Gyatso Mawepa:<sup>25</sup>

Four to five decades ago, at the place called Simuzum, there used to assemble witches from dusk to dawn and harmed the people and animals alike. One evening, a nun who was meditating at Risoong Cham-Khang, a secluded forest area, went to collect firewood adjacent to the place called 'Simuzum' meaning 'gathering place of the witches or rendezvous of the witches.' There she saw three witches assembled on a flat rock and preparing to cook something on the hearth. The nun hid herself in the bushes and threw a stone, which directly hit the pot on the hearth and overturned it. The frightened witches ran away some distance from the flat rock and one of the witches loudly enquired about the other in a strange language, '*Kur-to-Ma-Gnyek-Ka?*' The other replied, '*Kur-To-Gnyek-Pe-Jaam-Syo-Tong-Tong.*' The meaning and language of the words spoken by the witches are not understood till date.

Later at the arrival of His Holiness the Chyak-Thak Rimpoche at Gangyap, he understood the presence of evil spirits at Simuzum and was determined to pacify the evil spirits with his own method. Around the year 1915, one early morning before daybreak, His Holiness miraculously carried the big bulk of stones to the flat rock of Simuzum. When the last bulky stone was about to be piled up with the other stones on the flat rock where the witches used to assemble—this was at the break of dawn—a teenage Lepcha girl happened to pass through that place [the girl was called Mache Nyukon from Chongran, and passed by carrying a bamboo container, according to informant 8] and saw His Holiness with the big stone. Knowing that he was being watched, His Holiness instantly threw the stone at the bottom of the *katusl shokey* tree. Later on, His Holiness consecrated the pile of stones at Simuzum along with the three big *katusl shokey* trees around

---

<sup>25</sup> *Now!* 2005.

the flat rock. Two of the trees stand in the spot even to this day. From that time onwards, the evil spirits of Simuzum have ceased to trouble the people and it is believed that His Holiness Chyak-Thak Rinpoche subjugated the evil spirits not only of Simuzum but also of Mangthyang.

Informants 1 and 2 tell a slightly different version of the same story: While the abbot or rDo rje slob dpon of Zil gnon monastery was in meditation, his wife brought him food every day. One day, she saw seven ogresses (Tib. *srin mo*) cooking human bodies in a pot (according to informant 1, it was human babies' bodies). She threw a stone on the pot which broke. Three of the witches then talked to four others. Informant 2 quotes precisely the same dialog in an unknown language as Dawa Gyatso Mawepa, but translates it as "are you all right?" "We are fine but the pot is broken." Chathak Rinpoche came later and subdued the demons. Informant 2 concludes, "Before, this place was very dangerous and who ever was going there could die. Now, it is a holy place."

Chathak Rinpoche's achievement in blessing the land of Sikkim was elucidated by a recent event. In the village of Ran thang, three kilometres away from Phodong, a local family has undertaken the restoration of a 'temple for fasting' (Tib. *bsnyen gnas lha khang*) located next to a flat rock on which Rinpoche meditated. A *mchod rten* was built near the rock. In this village there is also a holy water spring that people link to Guru Rinpoche. This area therefore links Chathak Rinpoche and Guru Rinpoche. This link will be commented on in the conclusion.

At bKra shis sding (informant 4) or Yang rtse (informant 8), in a cave where he was meditating, Chathak Rinpoche found a stone on which Mi la ras pa's shape was naturally carved. He found this stone after trying to locate the source of the echo of the mantra he was reciting. Rinpoche then also became a 'treasure discoverer' (Tib. *gter ston*).

*In search of his 'secret consort' (Tib. gsang yum)*

According to informant 8, Chathak Rinpoche came to Sikkim motivated by the search for his consort. The details about his gSang yum's (Chathak Rinpoche's future wife) parents have been nowadays forgotten by their neighbours in Mangthiang. According to informant 1, her parents were farmers from Mangthiang and had fields in a place called Nambung Tarang, near sGang rgyab, and near the river, in a place called Dhim rop kyong. The father of Chathak Rinpoche's future

wife gave this latter land to her. One of her uncles was a forest guard for the Chogyal.

The story of Chathak Rinpoche's meeting with his future wife goes as such: According to informant 1, Chathak Rinpoche shot an arrow from rGyal shing to gSang ngags chos gling monastery where the niece of Kha' spyod gru dbang Rinpoche (also called Kha' spyod sKu zhog [informant 1] or Kun bzang bla ma [informant 8]) was meditating. Informant 8 says that the girl was meditating under her uncle's guidance<sup>26</sup> and was 18 years old. The arrow reached gSang ngags chos gling also according to informant 8, but it was in Kha' spyod dpal ri according to informant 2. Informant 8 describes Chathak Rinpoche's future wife as an assiduous Buddhist practitioner who meditated for twelve years.

Informant 1 continues the story saying "Shooting the arrow was like casting the dice and it is Kha' spyod gru dbang Rinpoche's niece who found the arrow. Some say that the arrow hit the mortar, whereas others say it hit the door of her meditation house." In informant 2's version, what informant 1 means by "casting the dice" appears to mean destiny determined by a previous life, which in Tibetan thought is called 'prophecy'. Chathak Rinpoche's arrow hit a bush where Kha' spyod Rinpoche's niece found it. The girl brought it to her uncle who explained, "It is a good sign that you will soon find a good person." Kha' spyod Rinpoche then put the arrow on the altar. In the evening, Chathak Rinpoche came looking for his arrow. Kha' spyod Rinpoche gave his niece to him saying, "It is according to the prophecy."

Informant 1 and 8 make clear that Kha' spyod Rinpoche's niece had carefully kept the arrow (she even wrapped it in a ceremonial scarf according to informant 1) and handed it over to Chathak Rinpoche when he came looking for it.

Further information, told later by the informants while mentioning Chathak Rinpoche's wedding, casts some light on the previous story. The girl was already promised to another man but she had refused this engagement. It was at that time that her uncle, Kha' spyod gru dbang Rinpoche, who was supporting her, told her that she had a good destiny and would meet a great husband. For this reason she went to meditate, waiting for her husband to come (informant 1). According to informant 6, gSang yum's elder sister got married to a man from bKra shis sding, but refused to go live in her in-law's house and died suddenly.

---

<sup>26</sup> Kha' spyod gru dbang Rin po che was the maternal uncle of lCags thag Rin po che's future wife.

Therefore, gSang yum was asked by her parents to go replace her elder sister, but as she was still a child, she refused.

Kha' spyod gru dbang Rinpoche is also an interesting character who links Chathak Rinpoche to a Sikkimese lineage of reincarnations. His story is told by informant 8 (it is also told, though with less details, by informant 1):

Kha' spyod gru dbang Rinpoche was a very poor Lepcha. He was a manual labourer, working for free to build the g.Yang thang palace, near Padma g.yang rtse. At that time, the Lepcha were neglected. He had to excavate earth and while doing it, he fell into deep trance. He used to say in Lepcha, "I did not come onto earth for this kind of work." Therefore, somebody told g.Yan thang Kazi (landlord) that he was useless for this work. He was 15 years old at that time. One day, he was going to Kha' spyod dpal ri and met gCong phung Mandal (Tsekhyim Ajo) on the way. gCong phung Mandal was angry because he could not find stones to build his house. At that time, when a house was being built, the owner had to provide the stones. Kha' spyod Rinpoche asked him what he was doing and, as the Mandal was in a bad mood, he told him to mind his own business. But Kha' spyod Rinpoche advised him to excavate in three places and left. Later, gCong phung Mandal found stones at the places mentioned by Rinpoche and was amazed.

Kha' spyod Rinpoche constructed the *mchod rten* which stands besides Kha' spyod dpal ri monastery, after the model of one from Kathmandu [the *mchod rten* Bya rung kha shor built by Ma bya gzig ma, a previous incarnation of Kha' spyod gru dbang Rinpoche according to informant 5]. He did not use any iron tools. His sponsor was Phenchung Mandal's father. When Rinpoche told him he was going to construct the *mchod rten*, the donor offered his help but Rinpoche refused. He constructed the *mchod rten* at night. When it was about to be completed, the donor came early one morning to meet Rinpoche and saw him carrying stones in the air and talking while nobody was there.

Rinpoche was the incarnation of Ma bya gzig ma (a name which literally means 'caretaker of the hens and cocks'). Later on, he went to bKra shis sding and constructed a *mchod rten*—the one which has the 'vase' part up side down—behind the *mchod rten* mThong ba rang grol. When it was near completion, his mother expired and he left the construction unfinished. Later on bKra shis sding lamas completed it. He also constructed the *ma ni* wall below the school ground in Zil snyan Bazaar. When it was completed, a golden cock and a golden hen were seen flying. People thanked Rinpoche by offering him barley beer, but it was poisonous. This happened before Chathak Rinpoche's marriage. Chathak Rinpoche's future wife provided care to Kha' spyod



Rinpoche while he was dying. Once, when she was crying, he consoled her saying that everything is impermanent and that he will come back to take her first milk. He said that in the presence of the public and died one week later. Kha' spyod gru dbang Rinpoche reincarnated as Chathak Rinpoche's first son.<sup>27</sup>

What Chathak Rinpoche and Kha' spyod Rinpoche's niece did after their first meeting is unclear. A story concerning Chathak Rinpoche's future wife, which happened before their first meeting, is told in addition to the story of the arrow shot in gSang ngags chos gling to show that Chathak Rinpoche and her were destined to meet. Informant 1 indeed explains: One morning, while Chathak Rinpoche's future wife was in sGang rgyab combing her hair, five objects that looked like butterflies fell on her (it was some kind of marbles or crystals according to informant 8; some golden pearls according to informant 4). She took it to mKha' spyod dpal ri to show it to her uncle (because her parents had advised her to go meet her spiritual guide to ask for the meaning of these objects, according to informant 8). The latter put the objects under a ritual bell and told her niece, "Don't become a daughter-in-law [i.e. do not get married right now], you have a good destiny [i.e. you will meet a high ranked husband] and you should practice the dharma [waiting for this husband]." According to informant 8, the uncle rather said, "Go to meditate in lHa ri snying phuk. You will meet your husband and you will have five sons bright as crystal." According to informant 4, the uncle concluded from the event that his niece was a *ḍākinī*.

Therefore, says informant 1, she did a retreat (Tib. *mtshams*) in the meditation house of the cremation ground in Zil gnon. Later, she meditated for one year in gSang ngags chos gling and during this time Chathak Rinpoche sent the arrow.

According to informant 8, the niece followed her uncle's advice and went to lHa ri snying phuk. But after a week of meditating alone, she heard drums and a trumpet. It scared her and she decided to leave. On her way back, she met Chathak Rinpoche at a place called rKang gling ga. They smiled at each other and went their own way.

Informant 1 adds, "We do not know what happened to the five objects; A nyo lags (Chathak Rinpoche's consort) asked her uncle for them but he did not give them back, maybe they were lost." The objects have disappeared by themselves according to informant 8. Informant 4 tells that, after the golden pearls had fallen on her dress, the girl showed

---

<sup>27</sup> This lineage is different from the one of the mKha' spyod sprul sku, whose previous incarnation was the *rdo rje slob dpon* of Padma g.yang rtse.

them to her father, but when the latter touched them, the objects turned black. But in mKha' spyod dpal ri, the uncle practiced a purification ritual (Tib. *khros gsol*) and the pearls became golden again.

Informant 1 and 2 explain that Chathak Rinpoche then went to sGang rgyab where the girl was living and made offerings to her parents, asking for her hand. He offered a plate (Lk.<sup>28</sup> *khang sa les sder*), a vase (Tib. *bum pa*) and some money from Tibet (Tib. *zho gang* or 'one unit of currency'). The parents agreed to give their daughter and the couple left for Tibet the next day (informant 1). But when the couple was leaving, the girl's uncles and villagers, disagreeing with her departure because she had been promised to another man, followed them asking "Why do you take our daughter-in-law?" (Informant 1)

But according to informant 8, the couple eloped to Tibet, without asking the girl's parents. We can assume that the girl's previous engagement, as well as their being followed by villagers, led to this conception. This view is shared by informant 6 who explains that when gSang yum's father learnt that a 'yogī type lama' from Tibet wanted to take his daughter, he opposed it and sent people after the couple to catch her and bring her back. Both informants then tell stories about the couple's escape. Informant 8's narration highlights Chathak Rinpoche's extraordinary powers:

When the villagers learnt that A nyo lags (gSang yum) had left with Chathak Rinpoche, they started to follow them until the Rangit River towards Ralang. When A nyo lags learnt she was being followed, she became nervous. On the Rangit river's bank, Chathak Rinpoche told her to sit on a stone; he then drew a line around the stone with an arrow and sat on another stone. When the people arrived, they demanded him to show the girl. Chathak Rinpoche told them to search by themselves and take her. But nobody could see her. She was very near and scared. Chathak Rinpoche told her not to panic. Later when the villagers left, he erased the line. The couple then left for Khams, which they reached after three months.

Informant 8's story of the escape displays the people's suspicions raised by Chathak Rinpoche's foreign origin and uncommon appearance, the strong commitment between Rinpoche and his wife as well as gSang yum's great powers and courage (the story is summarised here). He tells that when Chathak Rinpoche learnt that gSang yum's father was looking for her, he asked his assistant to hide her. This assistant was a man from Bhutan, according to informant 1,

---

<sup>28</sup> The mention 'Lk.' indicates words in *lho skad* i.e. the dialect of Tibetan spoken in Sikkim.

called 'Brug pa sgom chen.<sup>29</sup> He was living in Zil gnon and accompanying Chathak Rinpoche whenever the latter was travelling.

The assistant was hiding gSang yum from place to place while Chathak Rinpoche was moving on his side. Once, Chathak Rinpoche sent a letter to gSang yum's father, asking for her hand. But the father refused and angrily said, "I don't want to give my daughter to a stranger; we don't know him." But gSang yum's two brothers were supporting her and helped her to hide. Informant 8 then describes a route of escape going mainly through holy places, such as mKha' spyod dpal ri, Kongri, lHa ri snying phuk, Ra lang hot springs and gSer skyems thang, where gSang yum and Chathak Rinpoche met up. The couple then headed for North Sikkim in order to reach Tibet. But in La chung, two lamas sent by the father had come before to ask the villagers to stop the girl when they see her. When they were returning from La chung, the lamas met Chathak Rinpoche's group. They took the girl with them to bring her back home. But on the way, while they were reaching a bridge at twilight, gSang yum pretended she needed to pass water. She went behind a bush and disappeared. The lamas searched for her but, though she was wearing a red cap, could not find her. They thought she had gone ahead and left. But she had gone back towards La chung, using the same way. Soon, she met Chathak Rinpoche who was coming in her direction. In La chung, villagers tried to stop them but 'Brug pa sgom chen hit them one after the other and so the group could go to Tibet.

*The yogī householder*

In Tibet, Chathak Rinpoche and his wife visited several holy places (informants 1 and 6), including lHa sa where they went to the Jo khang temple (informants 4 and 6). They stayed in Tibet for two years (informant 6) or four years (informant 8). According to informant 6, the couple was travelling from place to place by horse with a retinue of servants. Moreover, Chathak Rinpoche had a lot of sponsors, some high-ranking, in Tibet. People used to gather around and rub barley flour on his body in order to bless the food. Therefore, Chathak Rinpoche avoided crowds and, when in a sponsor's house, he stayed in a separate room and only sometimes gave audiences.

---

<sup>29</sup> His son, called Samten Donyo, is nowadays living in bKra shis sding. According to informant 6, 'Brug pa sgom chen and lCags thag Rin po che met in Tibet where the former was a pilgrim.

Chathak Rinpoche and his consort had their first son in Tibet during the Iron Dog year of 1910 (informant 5). This son was the incarnation (Tib. *yang srid*) of Kha' spyod gru dbang Rinpoche. According to informant 8, in Tibet, several *Rinpoche* recognized that the boy was incarnated and asked his father to leave him in Tibet. But Chathak Rinpoche replied that his son should live in Sikkim.

Chathak Rinpoche's second son was born in Sikkim in 1911 (informants 5 and 8). According to informant 6, Rinpoche and his family did not come back directly to Sikkim but, between 1910 and 1911, went to Kalimpong and Darjeeling. In Kalimpong, Chathak Rinpoche built the *mchod rten* at Ten Miles that I have mentioned earlier and informant 5 has a photo of a cave in which Rinpoche meditated. In the same town, Chathak Rinpoche performed miracles that the police understood as mischief's. Therefore, they put him in jail, but Rinpoche escaped after a very short time. The police put him back in jail but he escaped again. So finally, he was left in peace (informant 6).

Rinpoche did not like Kalimpong and soon left for Darjeeling. He did not like Darjeeling either so the family went back to sGang rgyab. gSang yum's father could not oppose their coming back and so let them stay (same informant).

Chathak Rinpoche and his family eventually settled in Mangthiang. From then until his death (i.e. during 47 years), he stayed in several houses in the sGang rgyab area, in an order which is uncertain. He and his consort stayed in Kongri (above sGang rgyab) for several years, in a place that the Lepchas call 'sKu zhog Partam.' 'sKu zhog' is a common Tibetan term of address for monks and high ranked persons; 'Partam' means 'flat land' in Lepcha language. Until that time, Chathak Rinpoche was indeed called 'sKu zhog' and not 'Rinpoche' (informants 1, 2 and 4). "People did not know yet that he was a *Rinpoche*," comments informant 4.<sup>30</sup>

This was probably before he settled in Mangthiang (informant 7). In Mangthiang, Chathak Rinpoche and his family stayed in a house acquired from one of gSang yum's uncles (same informant). This house can still be seen today. It is a typical Lepcha house supported by big thick wooden pillars and with one corner of the roof rounded down.

Eventually, the family got a new house in Palegang, which is in the northeastern part of sGang rgyab, near to Chathak Rinpoche's reliquary

---

<sup>30</sup> However, Tashi Densapa, who met lCags thag Rin po che twice in his youth (at the end of the 1940s and at the beginning of the 1950s), recalls that lCags thag Rin po che was then called 'Rin po che.'

(Tib. *sku gdung*), which was built later. This house might have been bought from Lepcha (informant 1) unless, as it was common at that time, Chathak Rinpoche just settled on land which was unoccupied and later, when the first survey was done, was registered in his family's name (informant 7). The house in Mangthiang was left for Chathak Rinpoche's sons (informant 1).

During this time period, Chathak Rinpoche meditated in several 'houses of meditation' (Tib. *mtshams khang*), like, for example, in bSam gtan chos gling on the hill above sGang rgyab (informant 7) and in Ri gsung above Zil gnon (informant 5). Informant 2 tells that Rinpoche also meditated in Dotsu, near Lasso. A lama once used to meditate in this place, but was killed by a hunter who wanted to rob him. The lama reincarnated as a demon, haunting the place and harming people. Chathak Rinpoche went to meditate there in the evening, naked. This was witnessed by informant 10's maternal grandmother. Chathak Rinpoche subdued the demon and the place became peaceful again.

Several stories display Rinpoche's visionary power. One of them tells that one morning, in sGang rgyab, Rinpoche's wife found him lightening butter lamps with a very sad look. gSang yum asked what had happened and Chathak Rinpoche answered that his mother had died that morning in Khams (informant 4). "After that," adds informant 4, "people knew that he was not an ordinary man." Another story concerns informant 4's father who was also informant 1's brother. This man, who I will call rDo rje, was a layman (Tib. *'jig rten bo*) and took Chathak Rinpoche as his 'root master.' Chathak Rinpoche advised rDo rje to follow the dharma path. Therefore, rDo rje went to bKra shis sding to recite *rDo rje gcod pa* 1100 times in the Gu ru lha khang. One day, rDo rje went to collect wood. It was a sunny day and he was feeling very hot when he saw some water coming out from two sides of a big rock. He was very thankful and bowed down in front of the rock before he drunk the water. Then he returned to the Gu ru lha khang, took one silver and one copper pot and went back to the rock to collect water. He left the pots there to fill up and went again to the Gu ru lha khang to get a clay pot. When he arrived at the rock, the copper pot was full and the silver one was empty. He poured the water of the copper pot in the clay pot, reversed the places of the copper and silver pots, and left. When he came back to the rock once again, the copper pot was full of water and the silver pot was empty. The following day, Chathak Rinpoche's eldest son arrived, bringing food sent by Rinpoche. He also brought a message from Rinpoche saying that he should send him some

'nectar' or 'holy water' (Tib. *khros*). Indeed, Chathak Rinpoche had foreseen rDo rje's discovery and knew that it was holy water. But rDo rje did not send any water, perhaps because he doubted his own ability, and after Chathak Rinpoche had died, he regretted it. After few years, he went to bKra shis sding and searched for the rock, but it had been blasted to build a road (informants 1 and 4).

In addition to this visionary power, Chathak Rinpoche could see through people's behaviour and motivations, as stories told by one of Captain Yongda's son show. One of these narrations tells that, once, while a porter was bringing goods from a donor to Rinpoche, he made fun of the family he was working for. When he arrived in Mangthiang, Chathak Rinpoche repeated to him what he had said on the way. Another time, a porter carrying oranges to Rinpoche told his companion that it would be nice to eat one to appease his thirst. When he reached Rinpoche's house, the latter asked him if his thirst was appeased now. Another visitor hid his tobacco under a stone on his way to Mangthiang, fearing that Rinpoche might discover it. The person had his interview with the holy man and, before leaving, Rinpoche told him not to forget his tobacco on his way back. Tashi Densapa recalls similar events: his aunts, who were nuns, went often walking from Gangtok to Mangthiang to meet Chathak Rinpoche. Each time, they feared that the holy man would not be home because it was common knowledge that he could forecast the arrival of visitors; when he knew their intention was just curiosity to see an atypical being, he would leave the house.

Chathak Rinpoche continued to travel within Sikkim throughout his married life. He often went away after staying home for two or three months. He would not say where he was going. Before each departure, he took a bath, tied his hair, put on his yogī's headdress and took his chains and bow and arrows. Then he would go to different places in Sikkim (informant 6). He left once to meet the 16<sup>th</sup> Kar ma pa in bKra shis sding. The rGyal ba Kar ma pa had indeed come to bKra shis sding and expressed the wish to visit Chathak Rinpoche in Mangthiang. But he finally did not go for a reason which is unknown (informant 7 supposes that Chathak Rinpoche dissuaded him to come to such a remote place). Therefore, Chathak Rinpoche went to bKra shis sding where he appeared suddenly at midnight. He then met the Kar ma pa and other *Rinpoche* who were present. The meeting was witnessed by mKha' 'gro Padma bde chen (rDo grub chen Rinpoche's consort). Chathak Rinpoche then left, vanishing at the monastery's gate (informant 7).

He also used to recite *rDo rje gcod pa* at crossroads with a very loud voice while sitting on a flat stone. Passers-by were usually surprised and some bowed down in front of him (informant 6).

Chathak Rinpoche taught his eldest son his way of practising. He mainly taught him to recite *rDo rje gcod pa*, but did not encourage him to join a monastery. He indeed told him, "It is very difficult to become a good lama in a monastery, don't do it. You have to recite the *ma ni* mantra with a compassionate heart and *rDo rje gcod pa*; then there is no need for you to go to a monastery" (informant 6). Concerning *rDo rje gcod pa*, Chathak Rinpoche used to say, "It is the simplest and the most precious one can do." But the eldest son had interest in religious practices and learnt reading and writing from local lamas.

When at home, Chathak Rinpoche received visitors coming from all over Sikkim (informant 1 saw visitors from Singyang, Gangtok, Nam rtse and Kalimpong). He was usually asked advices to cure sickness and to forecast the future but he did not perform rituals for laymen. He also had donors (Tib. *sbyin bdag*) - though only a few of them - because many did not recognize his power or were afraid of this half naked man wearing chains (informant 1). Soshing Yapla was one of Chathak Rinpoche's donors and after Rinpoche passed away, his family became mTshams po Rinpoche's sponsor. Informant 1 saw Barmiok and Rhenock Athing coming to visit Rinpoche. Pedak lama from Tikja (Captain Sonam Yongda's father) was also one of Chathak Rinpoche's sponsors. He had requested Chathak Rinpoche's help with a ritual to get a son, which led to Captain Yongda's birth. Pedak lama and his wife used to come to visit Chathak Rinpoche in Mangthiang, bringing bags of rice. Until Chathak Rinpoche's death, Captain Yongda's family sent rice every year to Chathak Rinpoche (according to one of Captain Yongda's sons). Until today, Chathak Rinpoche is Captain Yongda's 'root master.' According to Captain Yongda's family, Chathak Rinpoche has other donors in rGyal shing area. People from Nam rtse also visited him (informant 1) and, according to informant 8, Chathak Rinpoche's relationship with his donors from Nam rtse dated back to his first visit to Sikkim. Then, Chathak Rinpoche shot an arrow from Gangtok to Nam rtse and the arrow hit Nam rtse Kazi's house. Since this time, the Kazi was his sponsor.

#### *Chathak Rinpoche's chains*

These chains have already been mentioned several times. There are several versions concerning their origins and what they became. According to most informants, Chathak Rinpoche was wearing them

when he arrived in Sikkim. Tshering Wangchuk Barphungpa heard Chathak Rinpoche's devotees saying that, as Rinpoche was the incarnation of Thang stong rgyal po, he was in possession of one of the chains originally created by Thang stong rgyal po, which he wore as protection (Tib. *bsrung bo*). These chains were made of very precious metal.

A story related to Nam rtse Kazi gives another explanation for Chathak Rinpoche wearing chains (it is told by an informant who does not wish to be named). It also shows that Chathak Rinpoche's relationship to this kazi might not have always been peaceful. Nam rtse Kazi (born in 1893) was the lord of the estates of Nam rtse and Lasso (he was also known as Lasso Athing), which included sGang rgyab. The settling of Chathak Rinpoche in sGang rgyab started a dispute with the kazi over land or taxes. Most probably, the kazi asked Chathak Rinpoche to pay taxes, which he refused. Nam rtse Kazi therefore summoned Chathak Rinpoche to court in Nam rtse. The case went on for sometime and Chathak Rinpoche often had to go to Nam rtse. He would walk very fast, halt in Soshing Yapla's house for food and, upon arrival at the court, would knock his trident on the floor to announce it. Eventually, the dispute grew bitter and the kazi had Chathak Rinpoche enchained. Then Chathak Rinpoche kept the chains, most probably as a testimony of the kazi's oppressive power and disregard for religion. He may also have cursed the kazi's family. It is unlikely, however, that Chathak Rinpoche started to wear chains only after his dispute with Nam rtse Kazi—most of the informants indeed say that he came with them to Sikkim—but the court case story seems genuine.<sup>31</sup>

At the end of his life, Chathak Rinpoche was no longer wearing chains. According to informant 5, they were brought to a Tibetan blacksmith in Rum theg to be melted in order to make ritual instruments. But the metal would not melt so the chains were left aside. Eventually, the rings got scattered and lost. Tshering Wangchuk Barphungpa heard another explanation which could be about the event from which informant 5's version originates. The story says that the stone carver of bKra shis sding, mGar ba Lama,<sup>32</sup> requested sGang rgyab mTshams po Rinpoche—Chathak Rinpoche's eldest son—to donate his father's chains to be put inside a *mchod rten* (as *gzungs* or 'mystic formula') which was under construction at Rum theg and was

---

<sup>31</sup> More extensive research may uncover the archives of the court case as every kazi kept records of their judgements.

<sup>32</sup> *mGar ba* means 'blacksmith,' which could have led to the idea that the chains were to be melted.



being consecrated by the 16<sup>th</sup> Kar ma pa. mTshams po Rinpoche then offered most of his father's chains, but rings from Chathak Rinpoche's chains can still be seen in several people's houses in Sikkim.

*The end of a religious lineage*

Chathak Rinpoche passed away in the Earth Dog year of 1958 (informants 1, 2 and 4) at Palegang. His dead body was cremated near his house and a reliquary (Tib. *sku gdung*) was built by his family at the cremation place. This *sku gdung* is now abutted by those of Rinpoche's wife and first son. It is believed that Chathak Rinpoche was the last incarnation of his lineage and will not be born on earth again. Informant 1 comments, "He went to 'pure land' (Tib. *zhing khams*) and will not be back because he completed his work on earth." After meditating at the request of Chathak Rinpoche's son-in-law, the 16<sup>th</sup> Kar ma pa also realised that Rinpoche had gone to a 'pure land' (informant 7). Even Chathak Rinpoche himself had wished on more than one occasion that he would not come to Sikkim again, probably due to the severe hardships he had to face there coupled with constant harassment by law enforcers and the cold attitude of the locals shown towards him, mainly during the last part of his life (informant 7).

Informant 6 explains, "Usually, a lineage is enthroned in a monastery, but Chathak Rinpoche's first son said that his father will not incarnate again and that, therefore, there is no reason to build a monastery."

CONCLUSION

The passage of time has obviously transformed Chathak Rinpoche's life story. Few direct witnesses could be found and no direct descendants of Chathak Rinpoche could be interviewed. The first consequence of the passage of time has been to make Rinpoche more famous today than he ever was during his lifetime. Indeed, at that time, very few people knew about him mainly because he was living in a remote area of Sikkim. He was conscious of this as he asked his visitors, "Why did you come to this monkey's land?" a question heard by Tashi Densapa. This process of popularisation is supported by his family whose several members have gathered information about Chathak Rinpoche, sometimes publishing it in the newspaper, while others wish to write a book about him.

Secondly, the impression that some events of Chathak Rinpoche's life are today exaggerated cannot be avoided—which does not mean

that Rinpoche was not an achieved Buddhist practitioner or did not have any special abilities. The narrations presented here mainly inform us about the creative process of a modern time legend defined as a narration. Its subjects are real but perhaps transformed and made more attractive and even mingled with magic. Chathak Rinpoche's life story indeed presents an important feature of the legend: different versions of the parts of this legend exist, but often some details are described with great precision and remain unchanged from person to person—like the ogresses' dialog or the arrow shot on the door of gSang yum's meditation house—while the context of the narration remains uncertain.

Several elements of the narrations about Chathak Rinpoche nevertheless show that he shared common features with the figure of the Tibetan 'saintly madman,' one of those who "consciously echo the crazy behaviour of some of the Tantric siddhas of India,"<sup>33</sup> one of whom was his previous incarnation, Saraha. With the 'saintly madman', Chathak Rinpoche shared at the very least his bizarre mode of dress, his disdain for scholasticism, and probably his disregard for social hierarchy<sup>34</sup> as demonstrated by his marriage to a Lepcha woman and his resistance to the kazi. No account shows that he had disdain for social conventions, like the Tibetan 'saintly madmen,' but his appearance was uncommon enough to raise fear among common people. Mentioning the only photo that was taken of Rinpoche, informant 1 comments, "At least, for the photo, he has put something on his waist." Moreover, informant 6's version shows that Chathak Rinpoche was first considered a foreigner, at least by his future father-in-law. Therefore, his strangeness was double.

Chathak Rinpoche also shared with the 'saintly madmen' his great attainment, demonstrated by his powers. He could indeed walk extraordinarily fast, predict the future, cure illnesses, see through people, tame demons, etc. He was then seen as a holy man rather than as a crazy one.

The form of Buddhism that developed in Sikkim—the dominant form of Buddhism in Sikkim is one of the least monastic among the forms of Tibetan Buddhism, or the most involved in the worldly domain, without being much challenged by other forms which are almost not present in the State—allowed Chathak Rinpoche's transformation from stranger to holy man. Sikkim is also seen as a great holy place and attracts all kind of practitioners, but Chathak Rinpoche did more than visit. His link with Guru Rinpoche that I mentioned

---

<sup>33</sup> G. Samuel, 1993: 303.

<sup>34</sup> *Ibid.*

earlier, as well as his building of *mchod rten* and thrones at specific locations, as well as his transmission of the power of his body to its realisations, putting his chains inside, allow me to recall the link between the yogī's body, the right location of practice and the web of pilgrimage sites made by Sondra L. Hausner.<sup>35</sup> This author indeed stresses the importance of finding the right place of practice for the yogī to attain realisation. "The physical place of practice and the actual seat if the *yogī* gains importance through the concentrated energy of the *yogī* and that of those who have meditated there in the past. Further, these seats of practice are connected with a web of pilgrimage sites containing additional seats of practice."<sup>36</sup> Chathak Rinpoche added his own web of pilgrimage places to the holy land of Sikkim.

## BIBLIOGRAPHY

- Dawa Gyatso Mawepa. 2005. The real story of Simuzum, *Now!* 23 April, Gangtok.
- Gyatso, J. 1979, The Teachings of Thang-stong rGyal-po, in Aris, M. and Aung Suu Kyi (Eds), *Tibetan Studies in Honour of Hugh Richardson, Proceeding of the International Seminar on Tibetan Studies*: 111-119, Warminster: Aris and Phillips.
- Hausner, Sondra. 2006. The Erotic Aesthetics of Ecstatic Ascetics, in Linrothe, Rob (ed.), *Holy Madness: Portraits of Tantric Siddhas*, New York: Rubin Museum of Art and Serindia Publications: 164-177.
- mThu stobs rnam rgyal and Ye shes sgrol ma. 1908. *History of Sikkim*, English translation of 'bras ljongs lung bstan gsal ba'i me long, unpublished.
- Samuel, G. 1993. *Civilized Shamans: Buddhism in Tibetan societies*, Washington, London: Smithsonian Institution Press.
- Stearns, Cyrus. 2007. *King of the Empty Plain. The Tibetan Iron-Bridge Builder Tangtong Gyalpo*, Snow Lion Publication.
- Stein, R. A. 1951. Mi-nag et Si-hia, géographie historique et légendes ancestrales, *BEFEO*, XLIV, 1 (1947-1950): Paris, Hanoï.
- Stein, R. A. 1981. *La civilisation tibétaine*, Paris: le Sycomore, l'Asiathèque.
- Young, Serenity. 2007. Review of *Holy Madness: Portraits of Tantric Siddhas*, ed. Rob Linrothe. *Journal of the International Association of Tibetan Studies*, no. 3 (December 2007): 1-8. [www.thdl.org?id=T3132](http://www.thdl.org?id=T3132).

---

<sup>35</sup> 2006.

<sup>36</sup> Serenity Young, 2007: 4.

ANNEXE 1: THE INFORMANTS

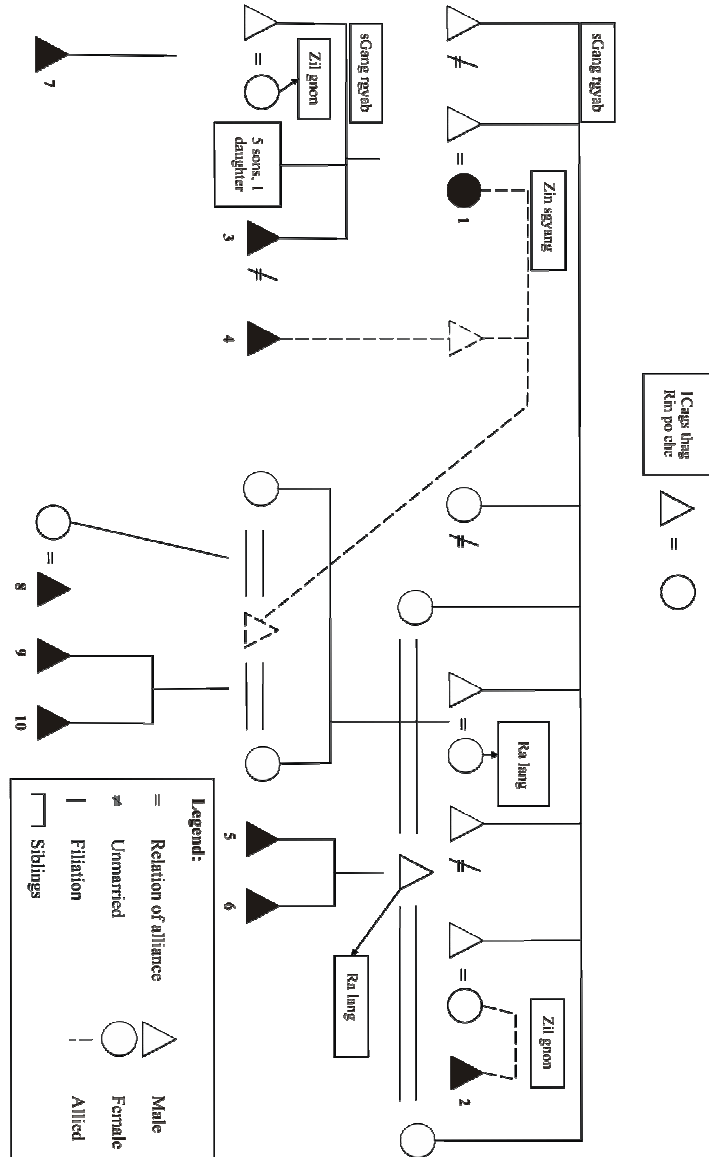

Annexe 2: A text about Chathak Rinpoche<sup>37</sup>

།ཕྱགས་ཐག་རྒྱུ་བཞེས་པ་མཚོ་ལྷོ་བཞེས་པ་བུ་མིར་ཏུ་ལྷོ་ཤོ་རོ་བྱེ་བའི་རྒྱུ་མཚོ་ལྷོ་ལྷོ་  
 བུ་མིར་བུ་ལྷོ་ལྷོ་བུ་མིར་བུ་ལྷོ་ལྷོ་བུ་མིར་བུ་ལྷོ་ལྷོ་བུ་མིར་བུ་ལྷོ་ལྷོ་བུ་མིར་བུ་ལྷོ་ལྷོ་  
 ཚེས་ལོ་མཚོ་ལྷོ་བུ་མིར་བུ་ལྷོ་ལྷོ་བུ་མིར་བུ་ལྷོ་ལྷོ་བུ་མིར་བུ་ལྷོ་ལྷོ་བུ་མིར་བུ་ལྷོ་ལྷོ་  
 བུ་མིར་བུ་ལྷོ་ལྷོ་བུ་མིར་བུ་ལྷོ་ལྷོ་བུ་མིར་བུ་ལྷོ་ལྷོ་བུ་མིར་བུ་ལྷོ་ལྷོ་བུ་མིར་བུ་ལྷོ་ལྷོ་  
 ལོ་ལྷོ་ལྷོ་བུ་མིར་བུ་ལྷོ་ལྷོ་བུ་མིར་བུ་ལྷོ་ལྷོ་བུ་མིར་བུ་ལྷོ་ལྷོ་བུ་མིར་བུ་ལྷོ་ལྷོ་

ལྷོ་ལྷོ་བུ་མིར་བུ་ལྷོ་ལྷོ་བུ་མིར་བུ་ལྷོ་ལྷོ་བུ་མིར་བུ་ལྷོ་ལྷོ་བུ་མིར་བུ་ལྷོ་ལྷོ་བུ་མིར་བུ་ལྷོ་ལྷོ་  
 ལྷོ་ལྷོ་བུ་མིར་བུ་ལྷོ་ལྷོ་བུ་མིར་བུ་ལྷོ་ལྷོ་བུ་མིར་བུ་ལྷོ་ལྷོ་བུ་མིར་བུ་ལྷོ་ལྷོ་བུ་མིར་བུ་ལྷོ་ལྷོ་  
 ལྷོ་ལྷོ་བུ་མིར་བུ་ལྷོ་ལྷོ་བུ་མིར་བུ་ལྷོ་ལྷོ་བུ་མིར་བུ་ལྷོ་ལྷོ་བུ་མིར་བུ་ལྷོ་ལྷོ་བུ་མིར་བུ་ལྷོ་ལྷོ་  
 ལྷོ་ལྷོ་བུ་མིར་བུ་ལྷོ་ལྷོ་བུ་མིར་བུ་ལྷོ་ལྷོ་བུ་མིར་བུ་ལྷོ་ལྷོ་བུ་མིར་བུ་ལྷོ་ལྷོ་བུ་མིར་བུ་ལྷོ་ལྷོ་  
 ལྷོ་ལྷོ་བུ་མིར་བུ་ལྷོ་ལྷོ་བུ་མིར་བུ་ལྷོ་ལྷོ་བུ་མིར་བུ་ལྷོ་ལྷོ་བུ་མིར་བུ་ལྷོ་ལྷོ་བུ་མིར་བུ་ལྷོ་ལྷོ་

<sup>37</sup> This text was found by informant's 7 in the old family house in Palegang. As it starts abruptly, it is likely that a first page was written, which has not been found in the house.

